

NOVO HABITAT

CONSTRUÇÃO RÁPIDA

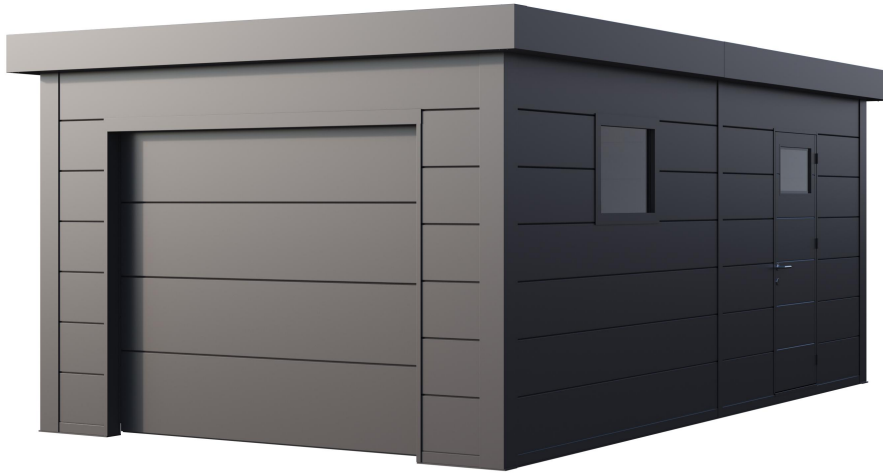

GARAGEM / GARAJE NH2

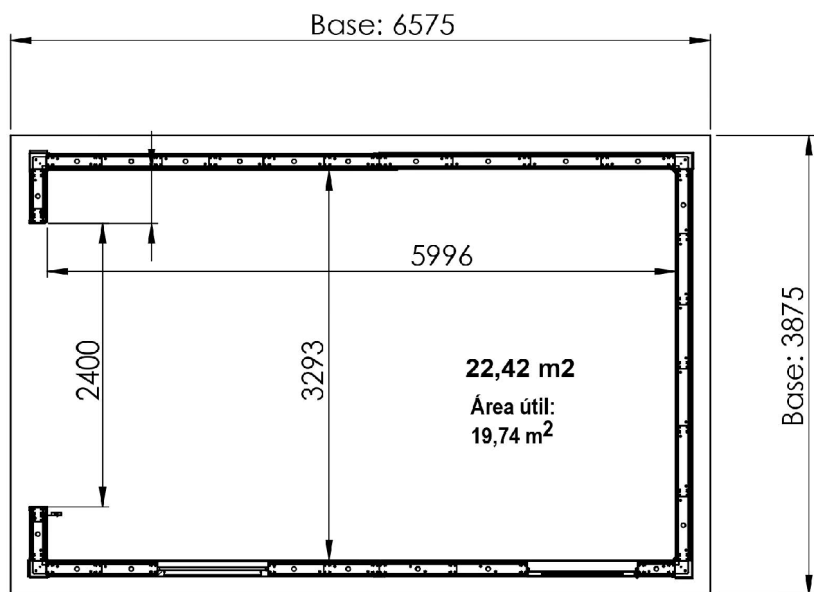

INSTRUÇÕES DE MONTAGEM
INSTRUCCIONES DE MONTAJE



Cor / Color:

-  Branco, Blanco
-  Cinza claro, Gris claro
-  Antracite, Antracita

GARAGEM / GARAJE NH2

Leia atentamente este manual.

Ele contém as propriedades técnicas e todas as informações necessárias para uma correta instalação.

Os dados técnicos nesta publicação estão sujeitos a alterações por motivos técnicos e / ou comerciais a qualquer momento e sem aviso prévio.

Lea este manual detenidamente.

Contiene las propiedades técnicas y toda la información necesaria para una correcta instalación.

Los datos técnicos de esta publicación están sujetos a cambios por motivos técnicos y / o comerciales en cualquier momento y sin previo aviso.



Leia o manual inteiro antes de começar a trabalhar

Lea todo el manual antes de comenzar a trabajar.



O uso de luvas é obrigatório.

El uso de guantes es obligatorio.



O uso de óculos de segurança é obrigatório.

El uso de gafas de seguridad es obligatorio.









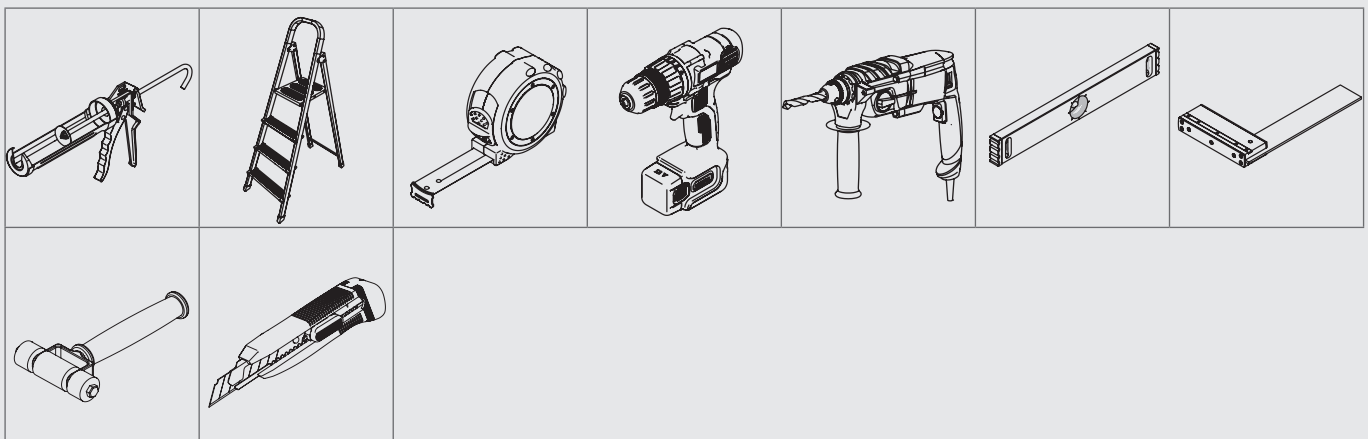

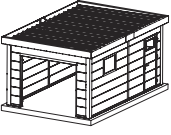
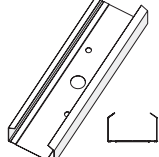
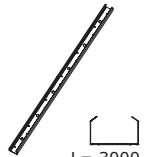
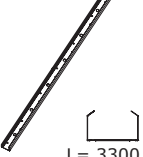
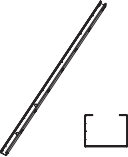
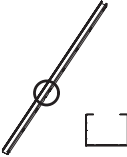
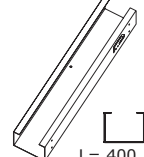
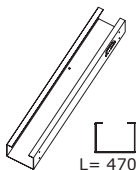
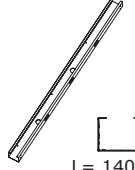

O uso de um capacete é obrigatório.

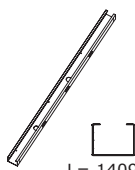
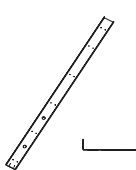
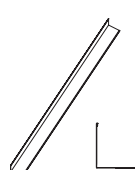
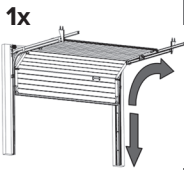
El uso de un casco es obligatorio.

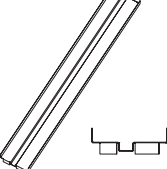
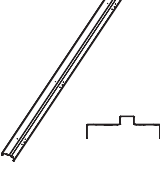
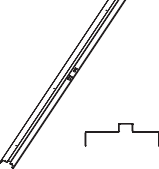
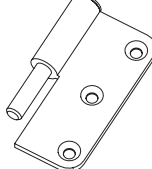
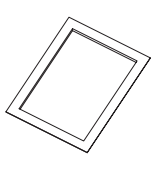
Lista de ferramentas / Lista de herramientas

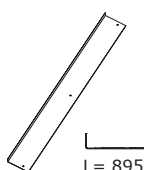
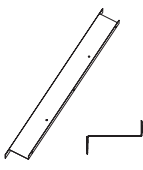
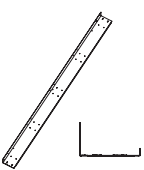
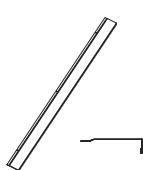
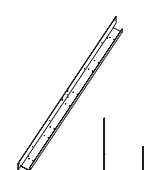
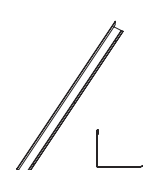
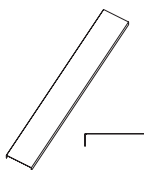
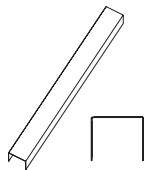
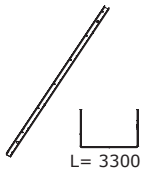
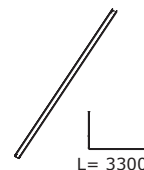
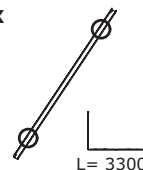
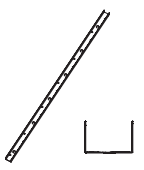
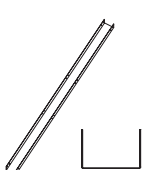
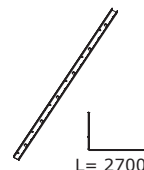

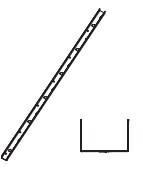
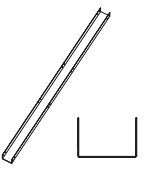
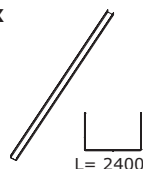
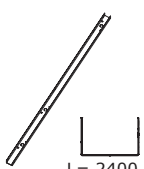
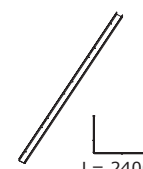
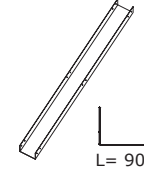
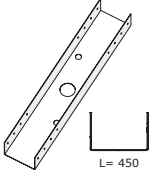
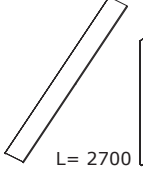
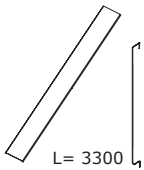
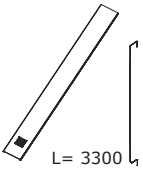
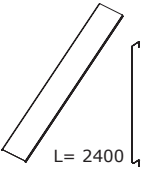

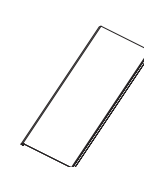
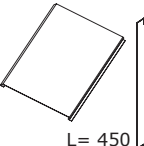
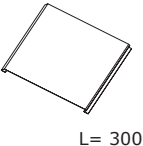



Lista de componentes / Lista de componentes

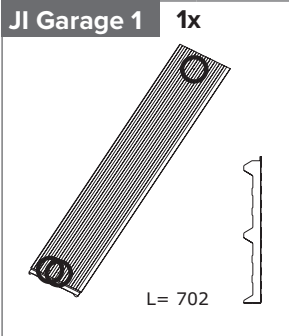
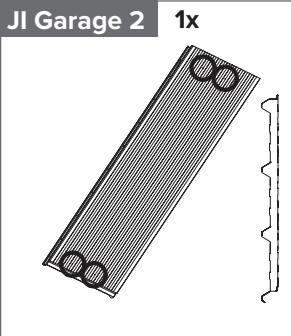
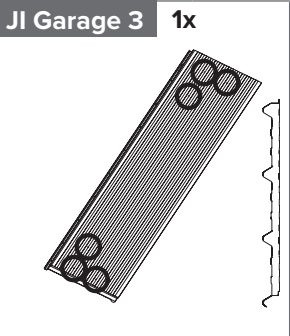
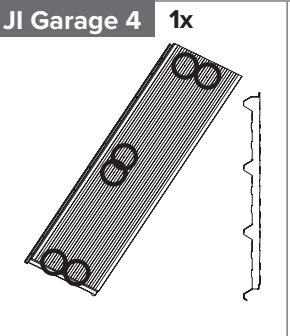
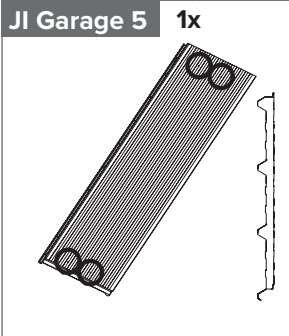
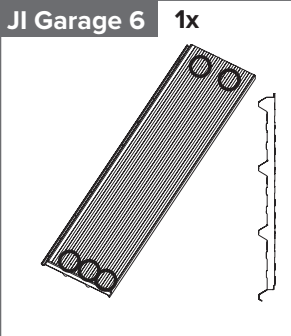
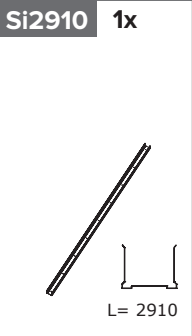
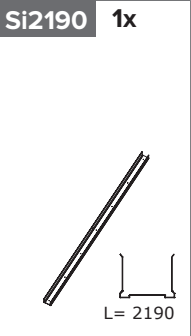
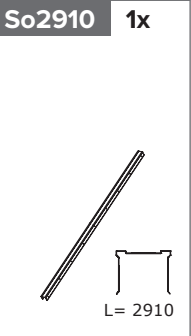
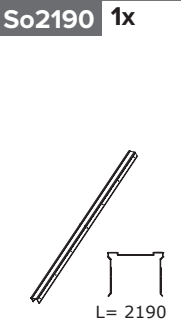
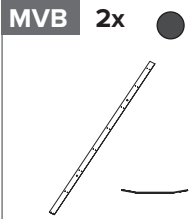
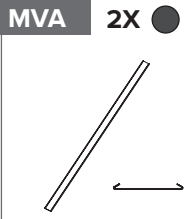
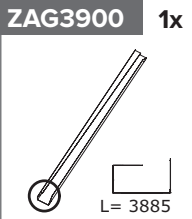
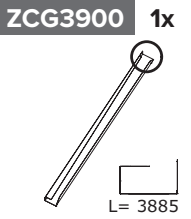
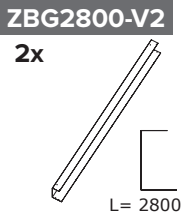
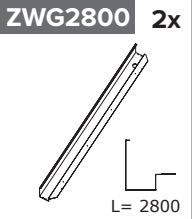
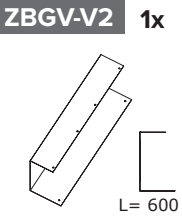
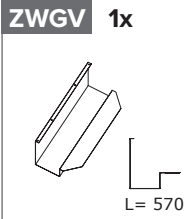
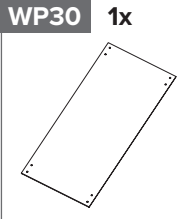
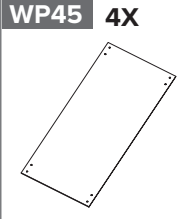
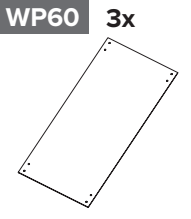
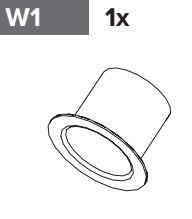
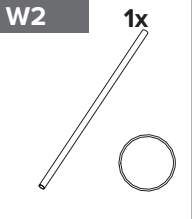
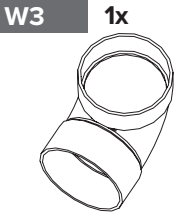
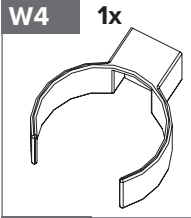
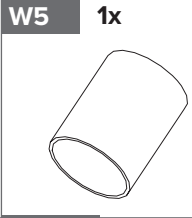
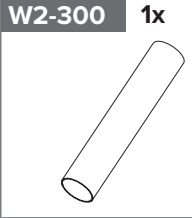
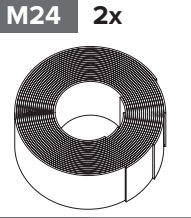
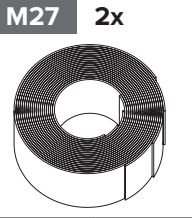

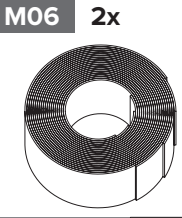
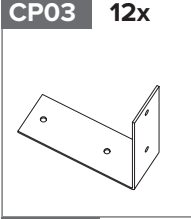
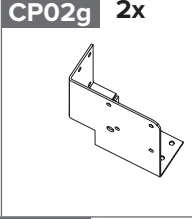
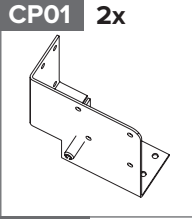
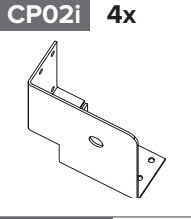
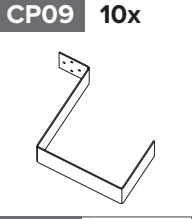
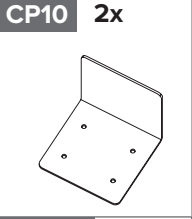
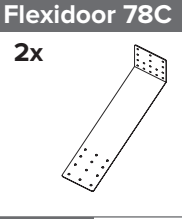
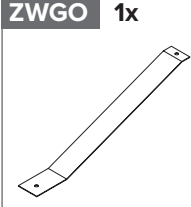
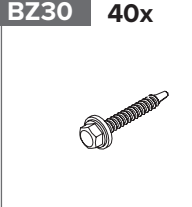
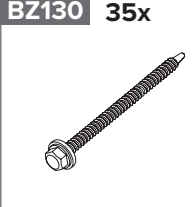

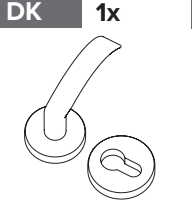
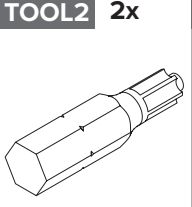

	A045G 2x 	A30 4x  L= 3000	A33 1x  L= 3300	B7 38x 	BD7 1x 	B1BW 6x  L= 400
B1BGP 5x  L= 470	B4OW 3x  L= 1409	B1BGP 5x  L= 470	B4OW 3x  L= 1409	F7 8x 	HA7 4x 	Flexidoor 2420 1x 
DR 1x 	KT09 1x 	K6R 1x 	K6LE 1x 	K6S 3x 	W90x2P 2x 	KM100 2x 
KHWG90 2x  L= 895	KVWG2P 2x 	KVG20 2x 	KVG20AF 2x 	KHG24 1x 	KHG24AF 1x 	FD09 1x 
UD09 1x 	J33 1x  L= 3300	JDA33 1x  L= 3300	JDA33_W24 1x  L= 3300	J27 1x 	JDA27 1x 	J27_W09 1x  L= 2700
JDA27_W09 1x  L= 2700	J24 1x 	JDA24 1x 	JDA24_W09 1x  L= 2400	JD24_ED 1x  L= 2400	J24_W24 1x  L= 2400	J09_W09 3x  L= 900
J045G 2x  L= 450	DA27 12x  L= 2700	DA33 7x  L= 3300	DA33VR 1x  L= 3300	DA24 8x  L= 2400	DA12 6x  L= 1200	DA09 4x 
DA045 12x  L= 450	DA03 6x  L= 300					

GARAGEM / GARAJE NH2

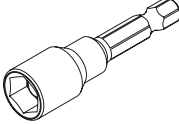
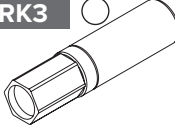
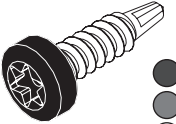
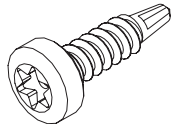
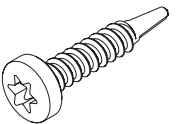
Lista de componentes / Lista de componentes

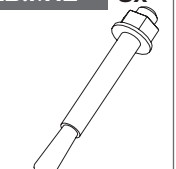
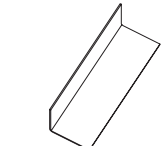
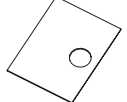
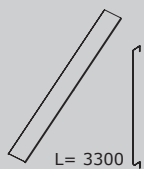
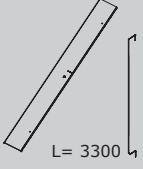
Jl Garage 1 1x 	Jl Garage 2 1x 	Jl Garage 3 1x 	Jl Garage 4 1x 				
Jl Garage 5 1x 	Jl Garage 6 1x 	Si2910 1x 	Si2190 1x 	So2910 1x 	So2190 1x 		
MVB 2x 	MVA 2x 	ZAG3900 1x 	ZCG3900 1x 	ZBG2800-V2 2x 	ZWG2800 2x 	ZBGV-V2 1x 	
ZWGV 1x 	WP30 1x 	WP45 4x 	WP60 3x 	W1 1x 	W2 1x 	W3 1x 	
W4 1x 	W5 1x 	W2-300 1x 	M24 2x 	M27 2x 	M33 1x 	M06 2x 	
CP03 12x 	CP02g 2x 	CP01 2x 	CP02i 4x 	CP09 10x 	CP10 2x 	Flexidoor 78C 2x 	
ZWGO 1x 	BZ30 40x 	BZ130 35x 	Jl33-SB 80x 	DK 1x 	TOOL2 2x 	TOOL3 2x 	

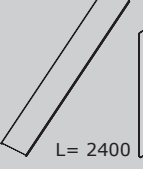
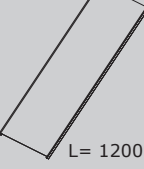
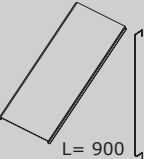
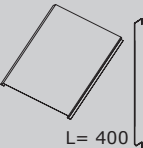
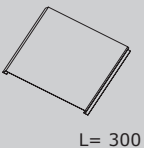
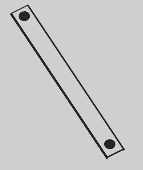
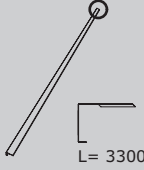
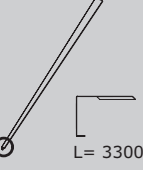
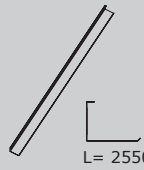
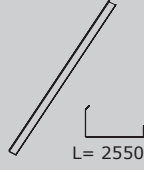
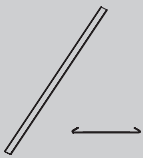
Lista de componentes / Lista de componentes

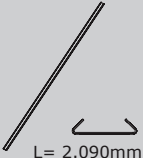
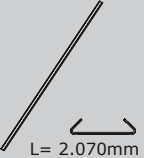
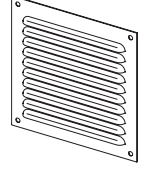
TOOL4 1x 	RK1 ● 1x RK2 ● RK3 ○ 	SD18 80x 	SD18 900x 	SD25 2x 	B.M8 4x 	KB.M12 8x 
KG-Hoek 2x 	RT0,9 8x 	DI33 6x  L= 3300	DI33G 1x  L= 3300	DI27 12x  L= 2700	DI24 8x  L= 2400	DI12 6x  L= 1200
DI09 4x  L= 900	DI04 12x  L= 400	DI03 6x  L= 300	DI33VL 1x 	XGA 1x  L= 3300	XGC 1x  L= 3300	XGBDH 2x  L= 2550
XGBDL 2x  L= 2550	MVA 2x ● 	MVB 2x ● 	IGaL 2x  L= 2.090mm	IGaK 2x  L= 2.070mm	ROOSTER 1x 	

Pressuposto / Presuposición

- O chão deve ser plano e nivelado.
O piso deve ser feito de tal forma que seja possível fixá-lo à garagem.
- El suelo debe ser plano y nivelado.
El piso debe ser hecho de tal forma que sea posible fijarlo a garaje.

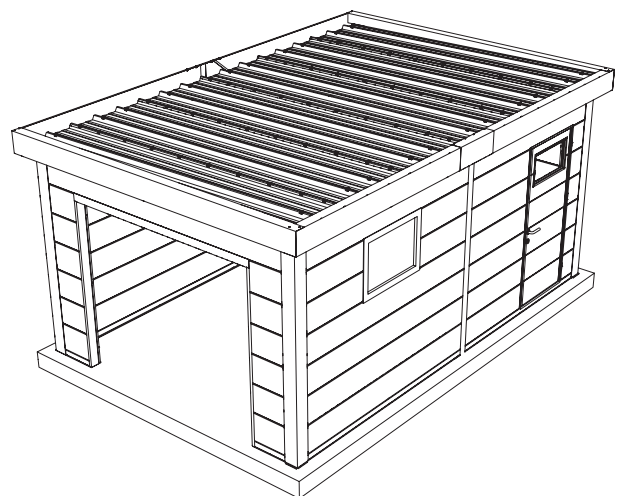

PS

- A garagem deve estar centrada na base.
- A garaje debe estar centrada na base.

1. Versão "porta à direita" / Versión "puerta a la derecha"



2. Versão "porta à esquerda" / Versión "puerta a la izquierda"



Composição / Composición

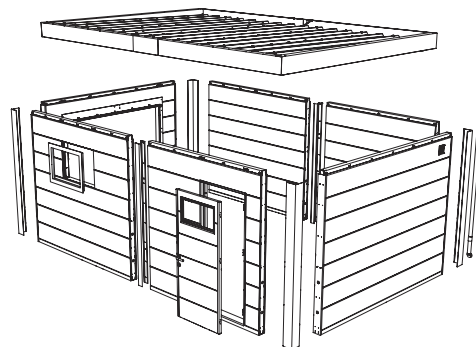
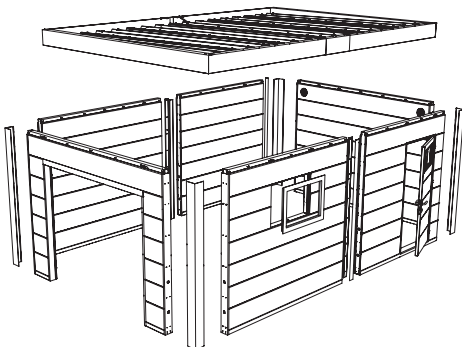
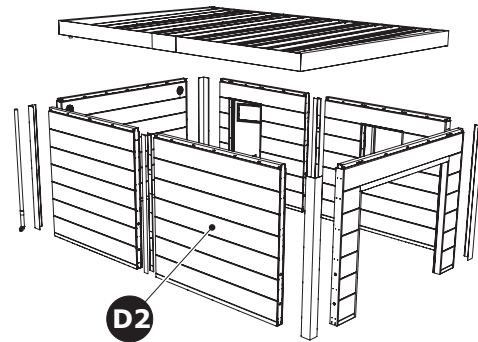
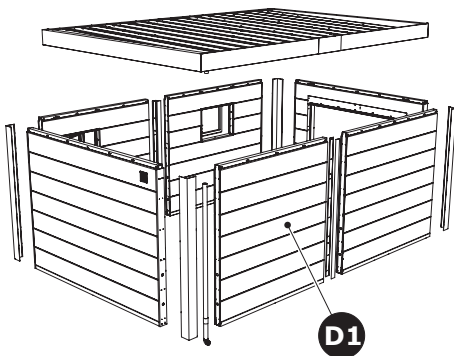
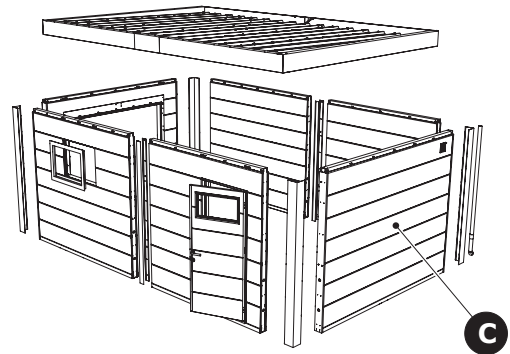
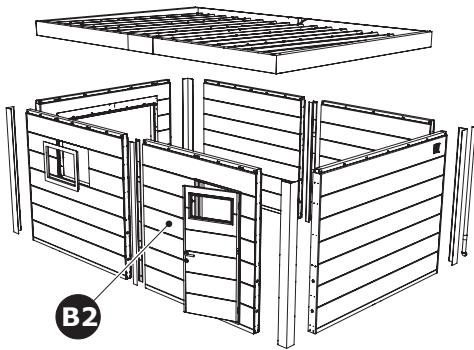
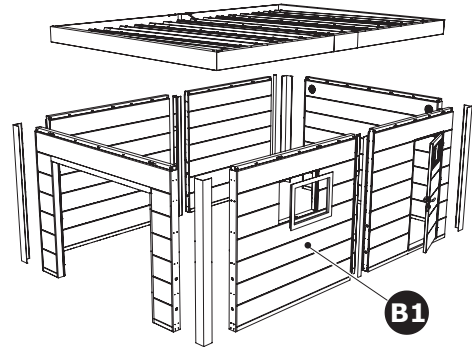
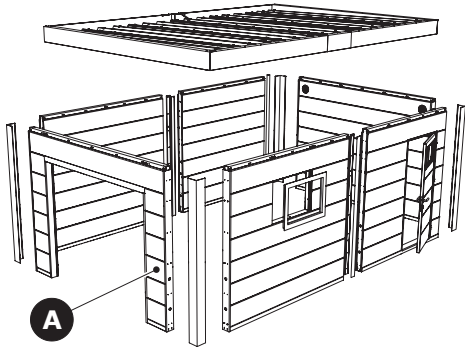

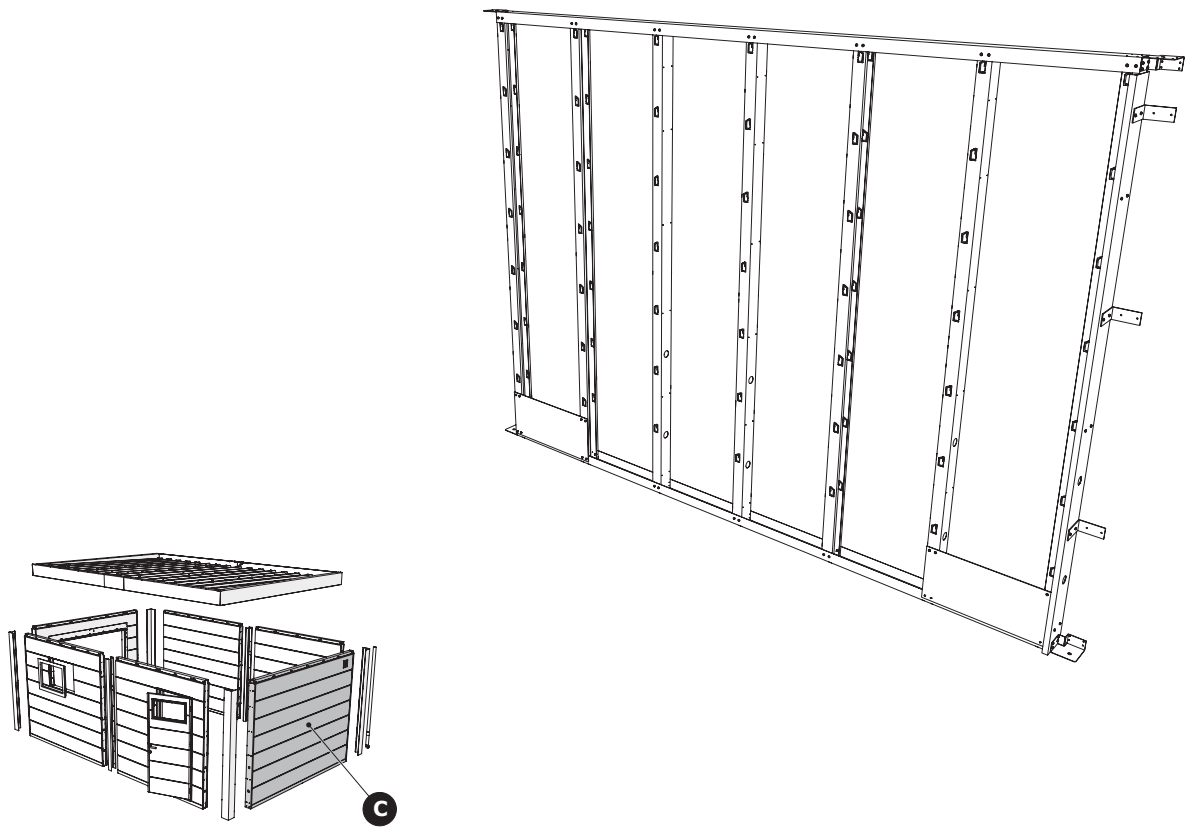

C Fachada / Fachada

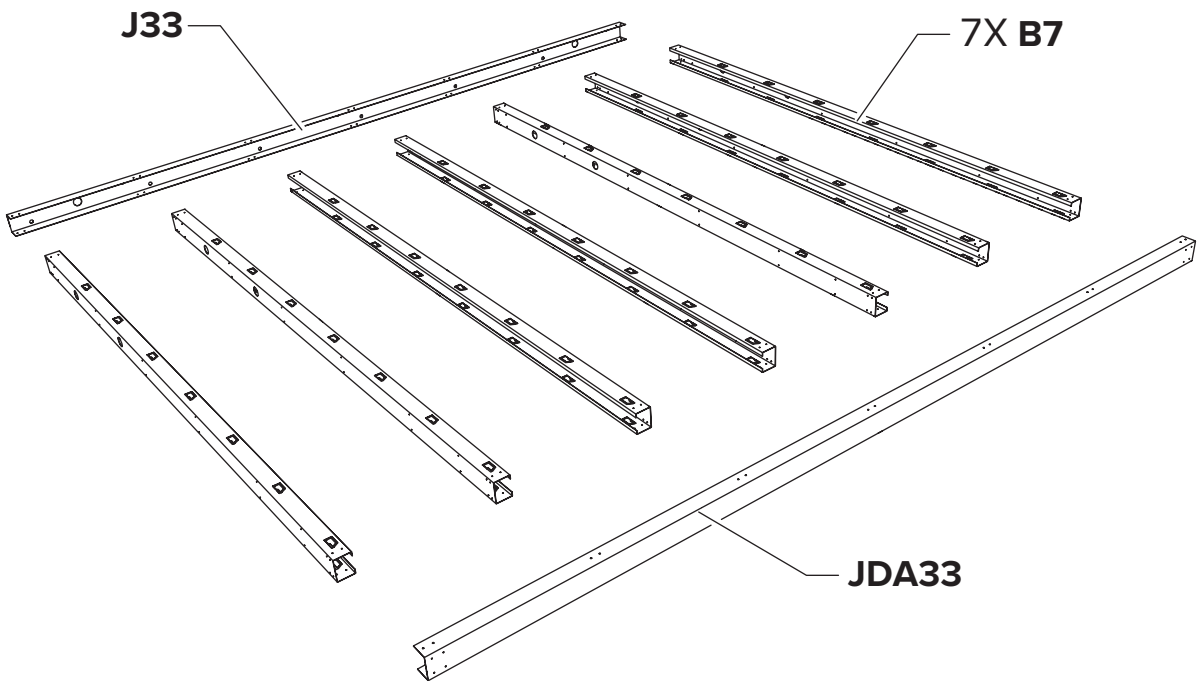

C Fachada / Fachada

POW

O princípio da construção da fachada (POW).
El principio de la construcción de la fachada (POW).

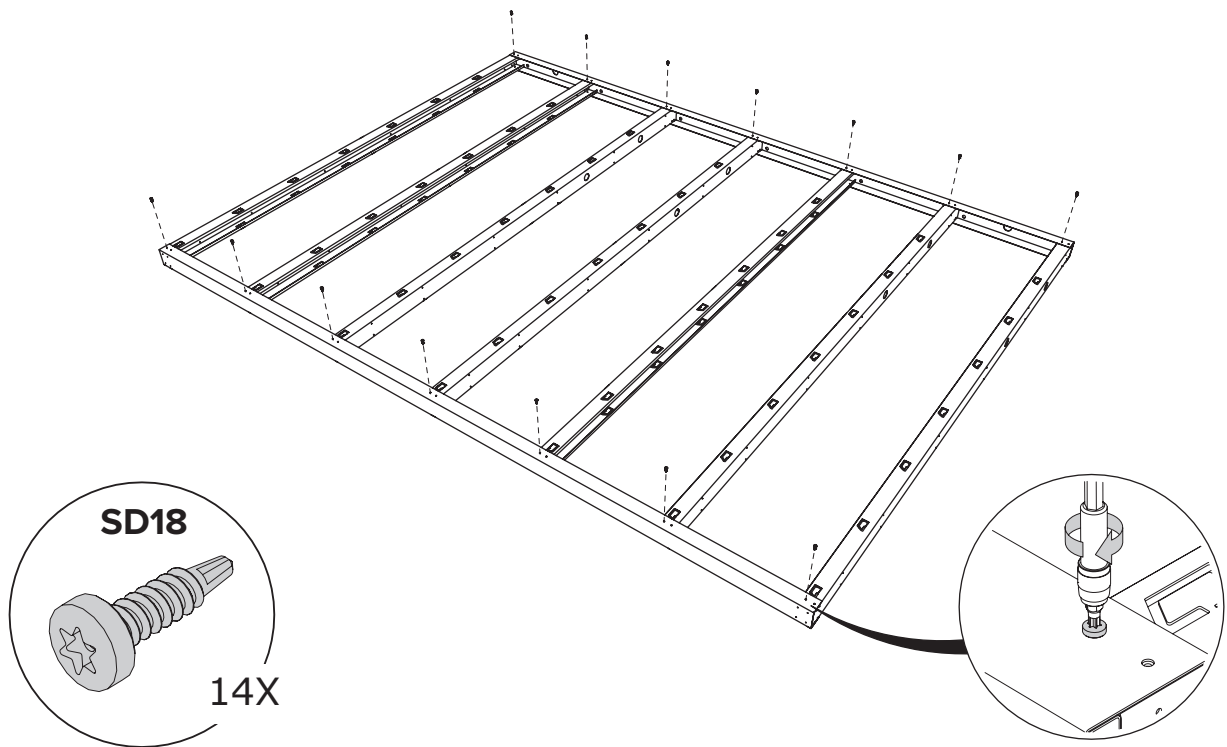

C Fachada / Fachada

POW

Virar o quadro / Girar marco

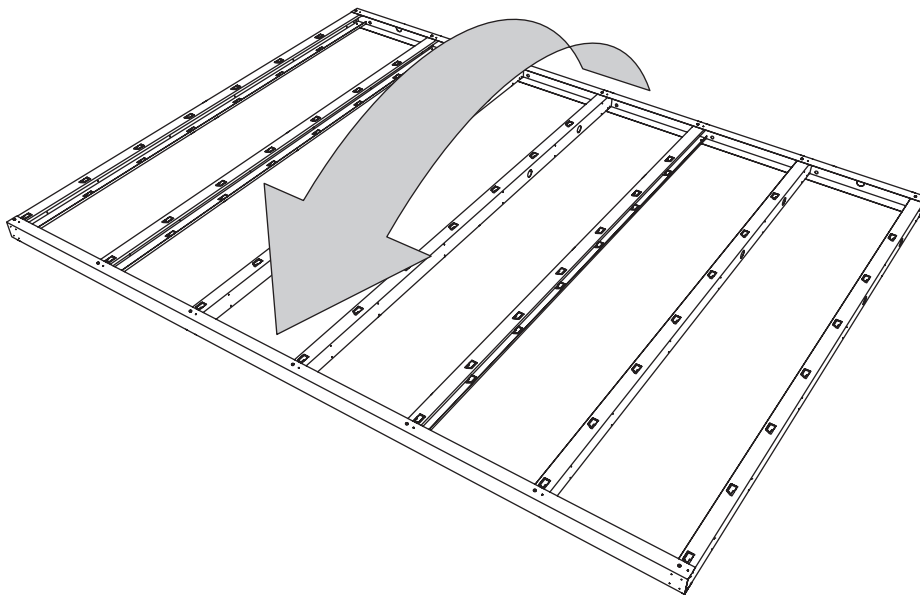

C Fachada / Fachada

POW

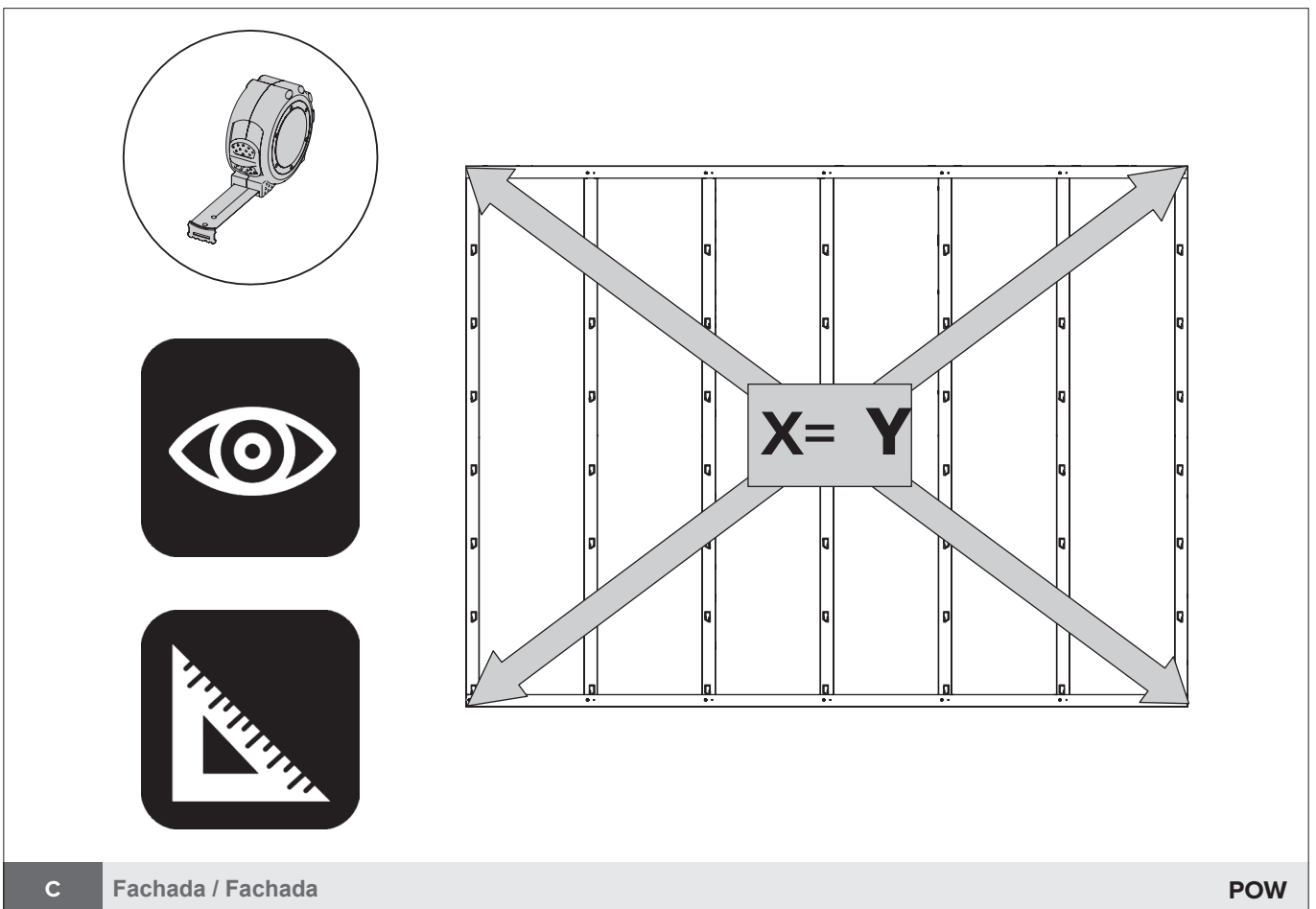
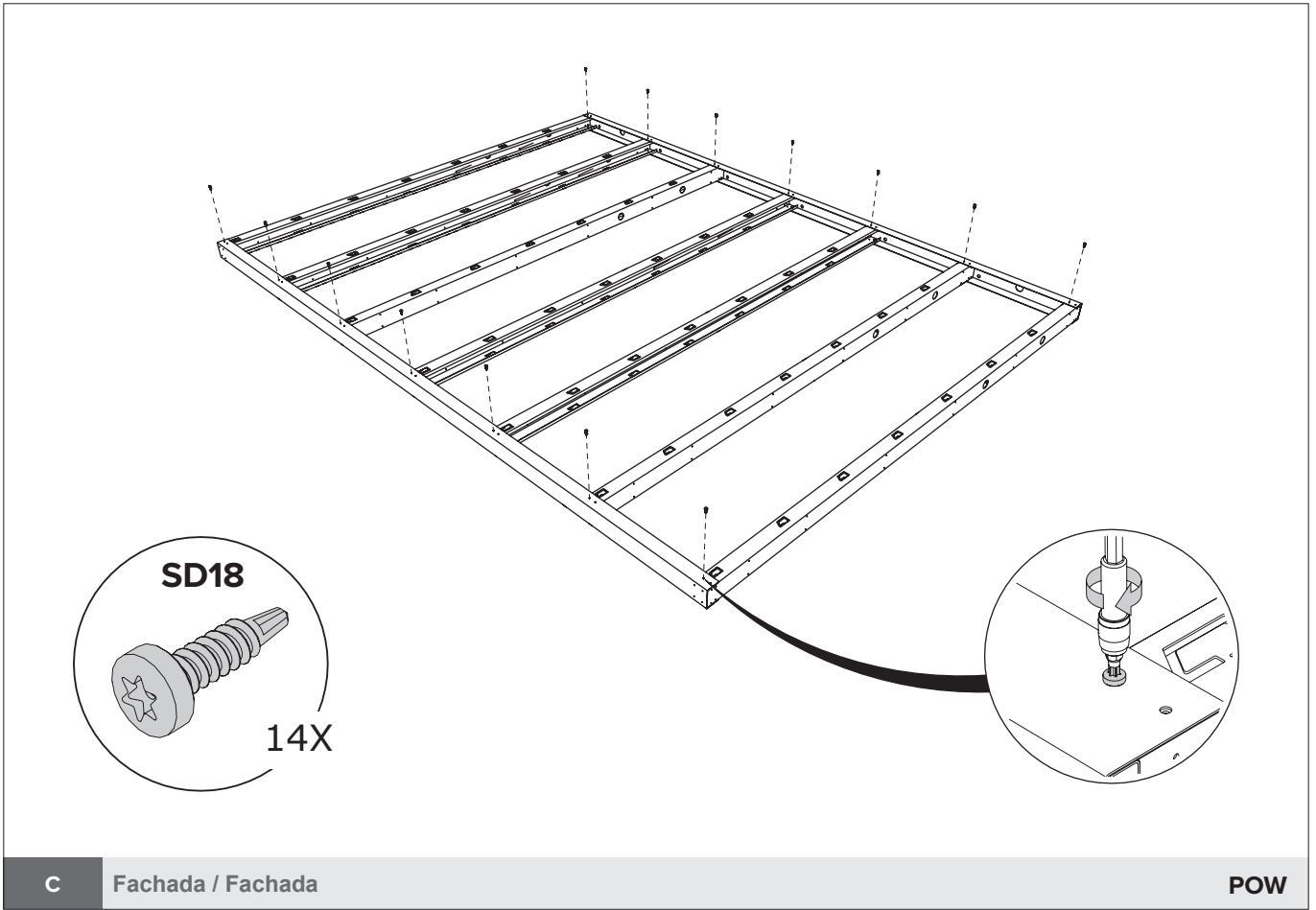

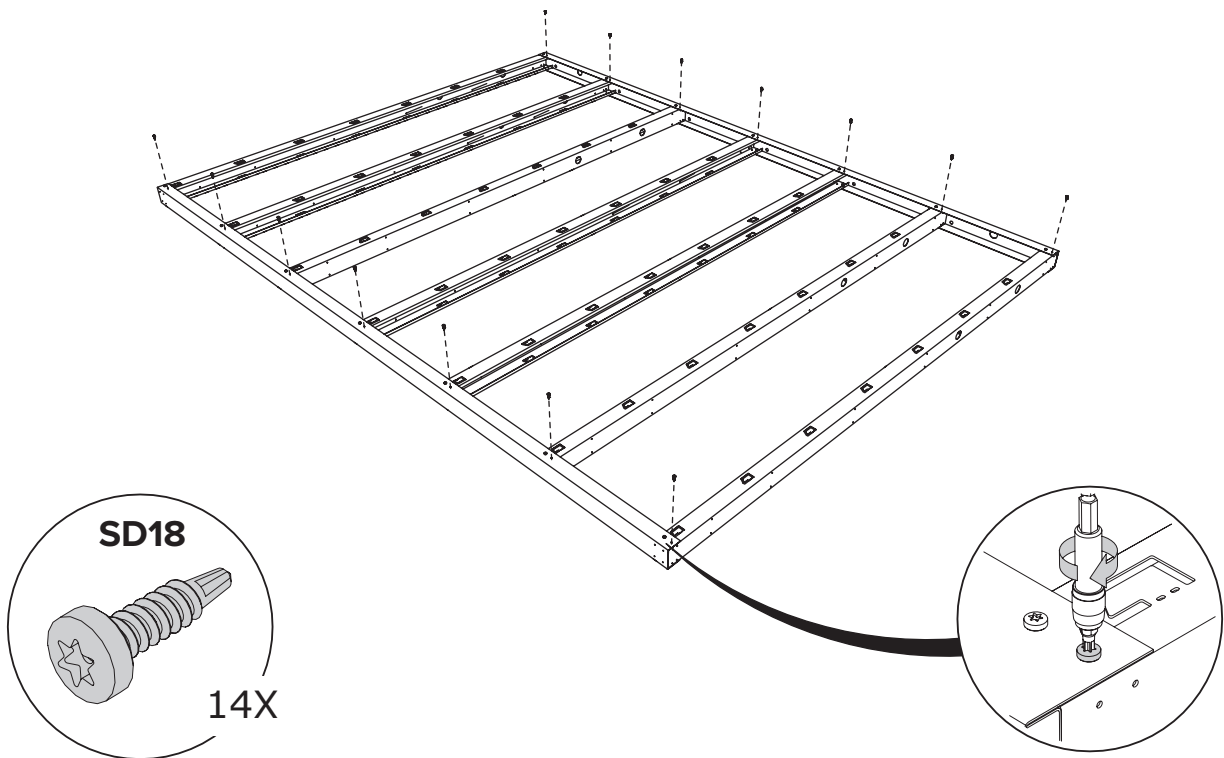

C Fachada / Fachada

POW

Virar o quadro / Girar marco

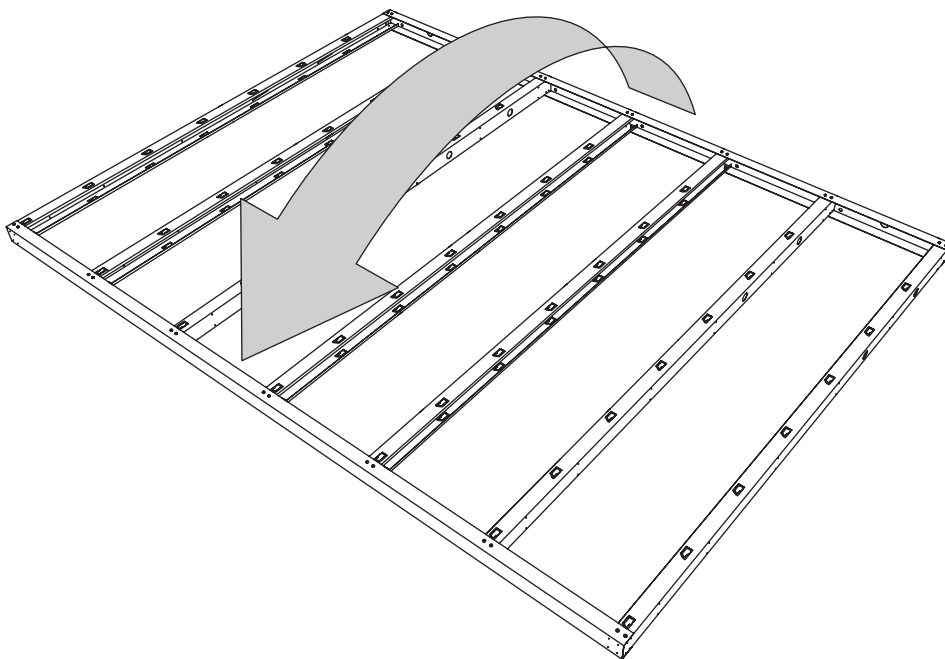

C Fachada / Fachada

POW

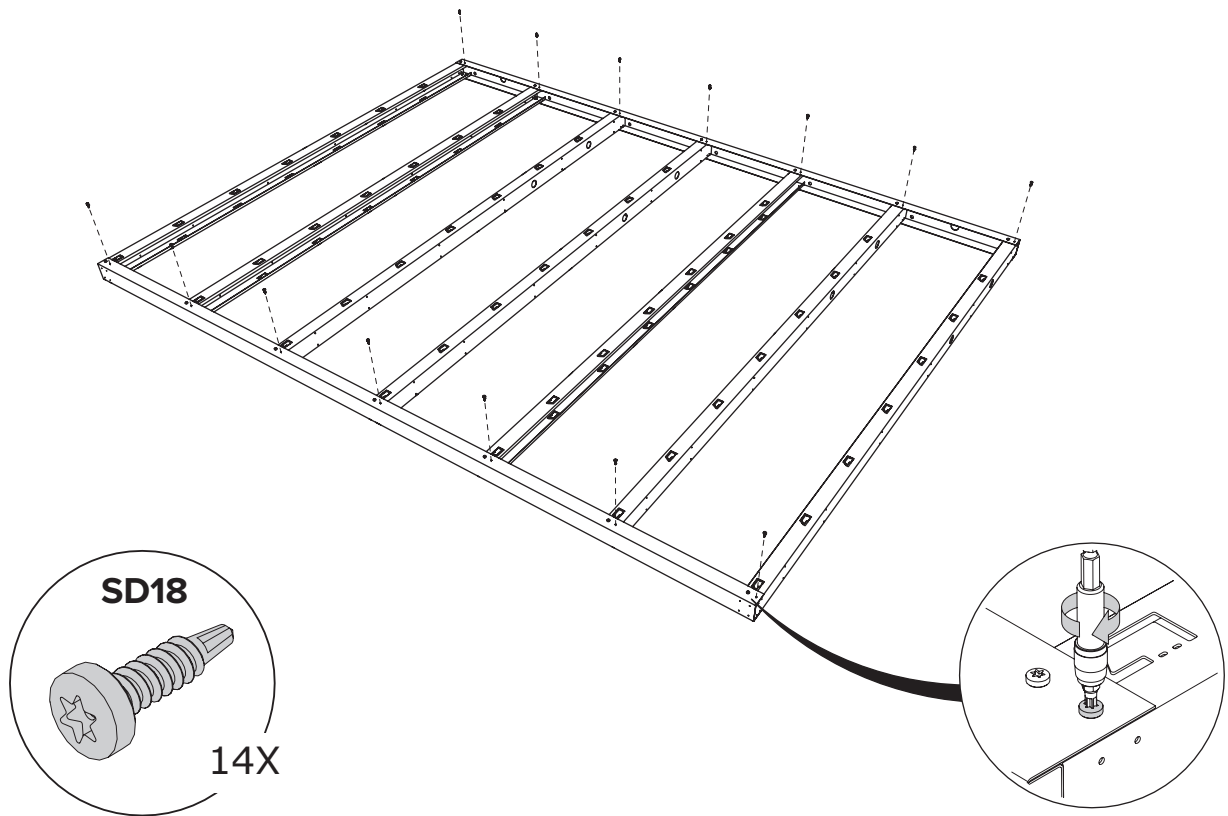

C Fachada / Fachada

POW

Virar o quadro / Girar marco

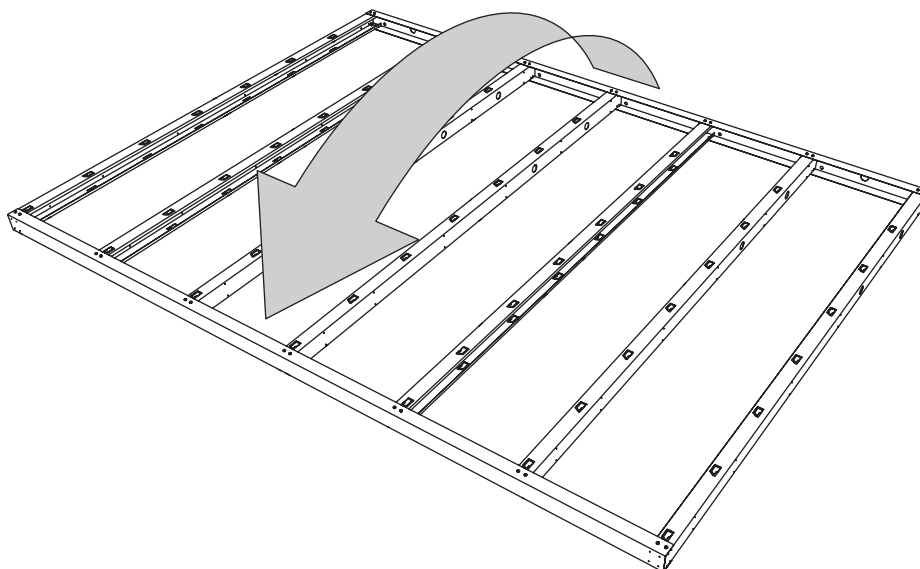

C Fachada / Fachada

POW

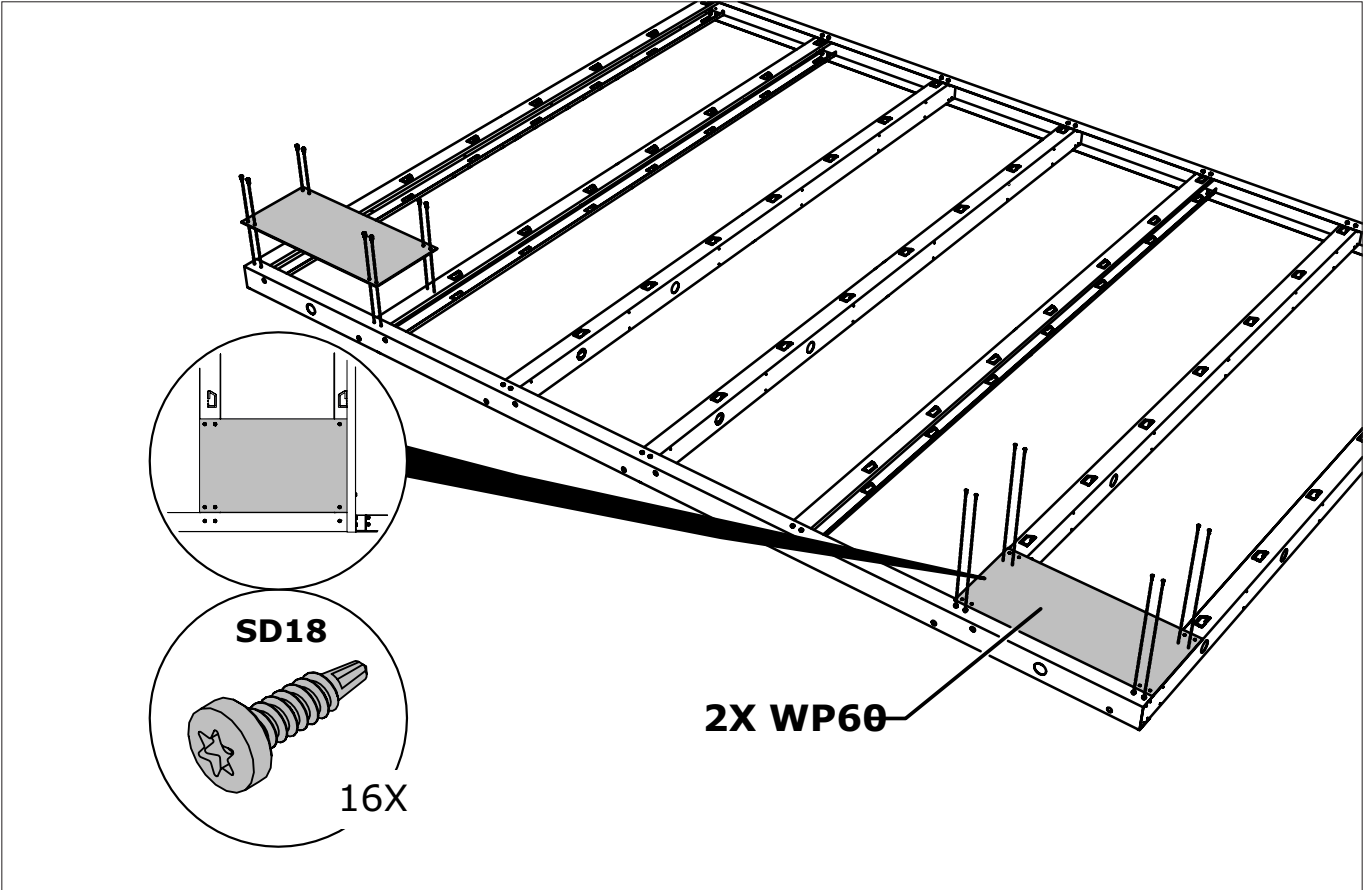

C Fachada / Fachada POW

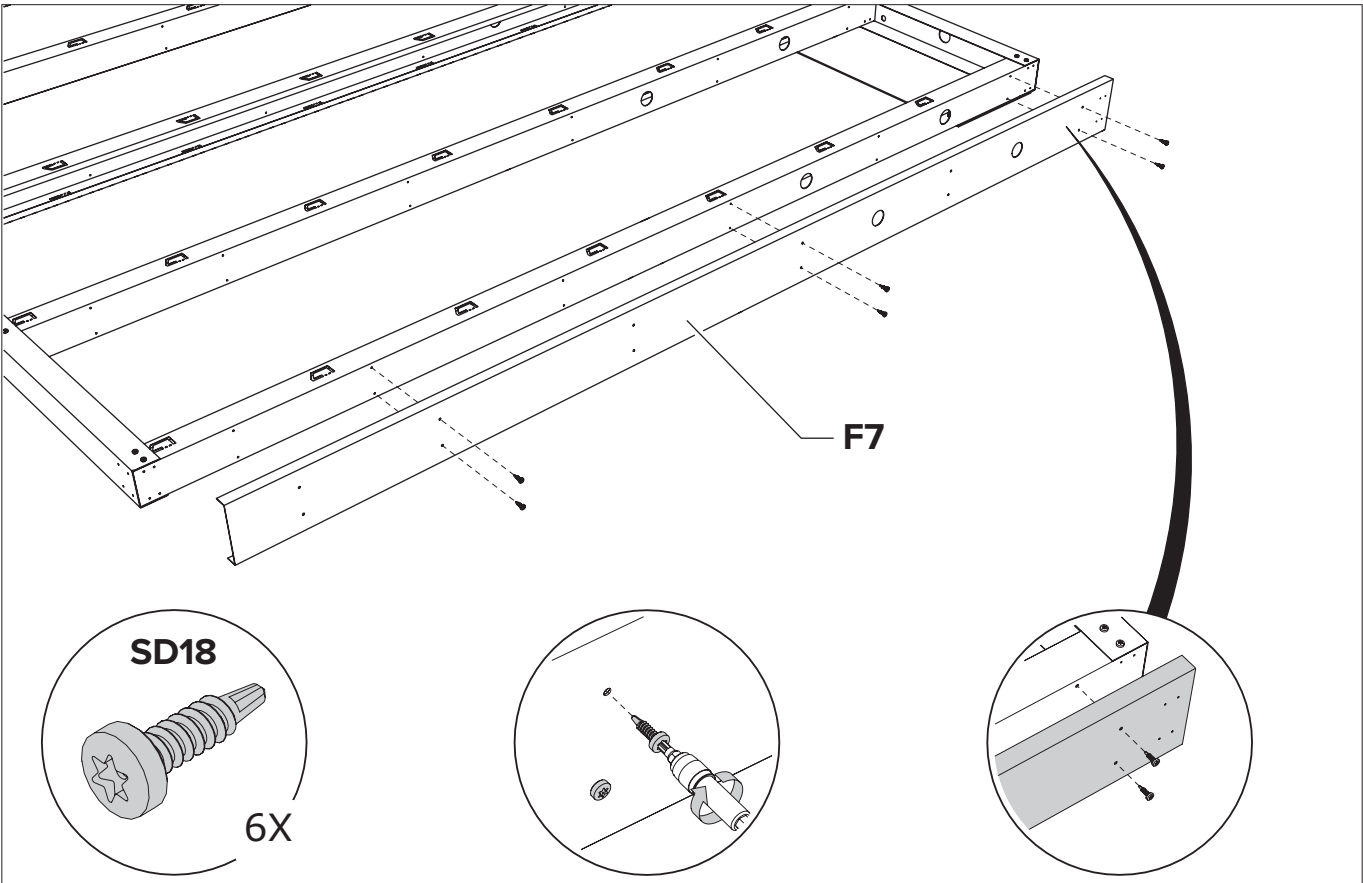

C Fachada / Fachada POW

GARAGEM / GARAJE NH2

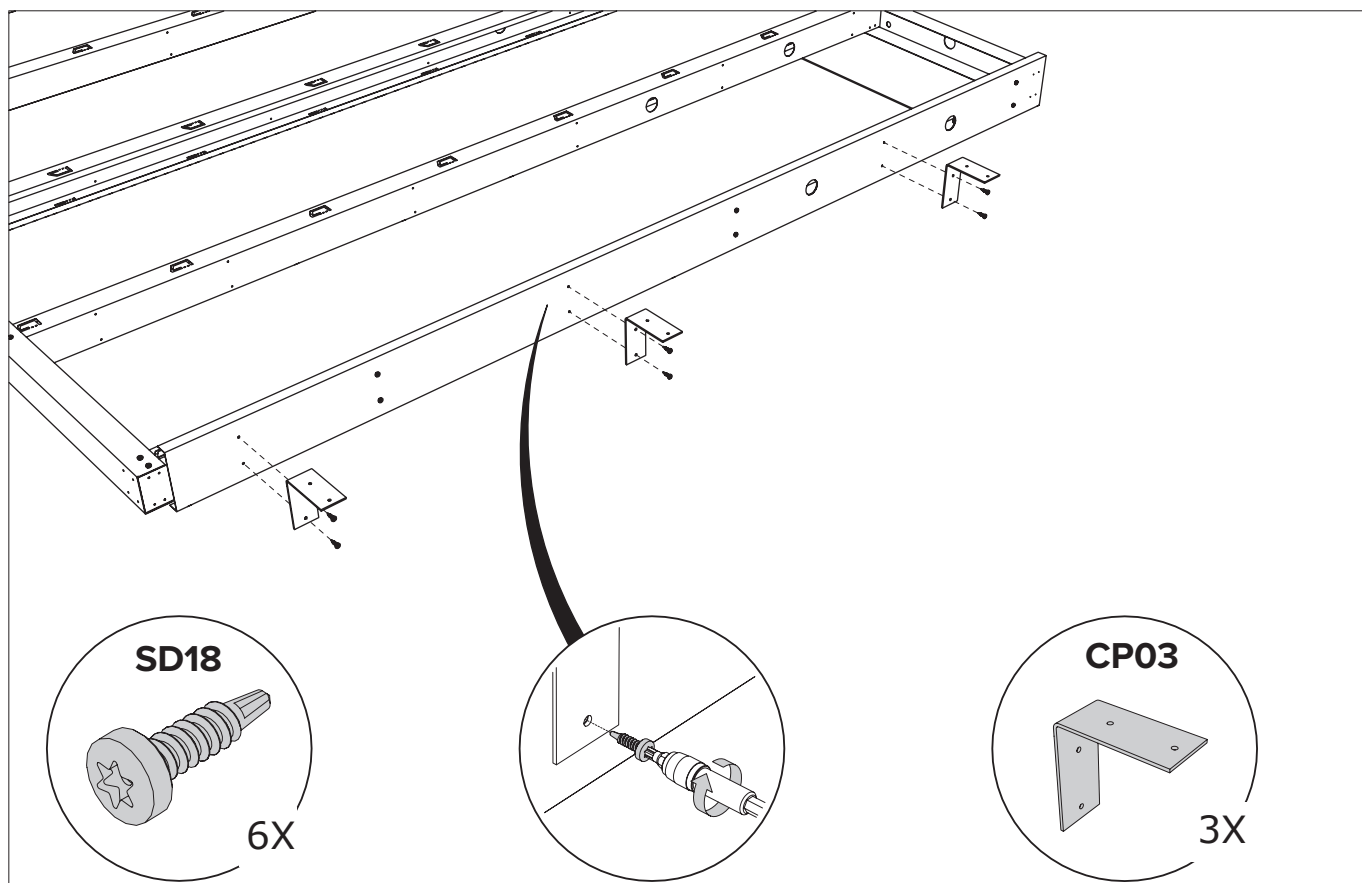

SD18

6X

CP03

3X

C

Fachada / Fachada

POW

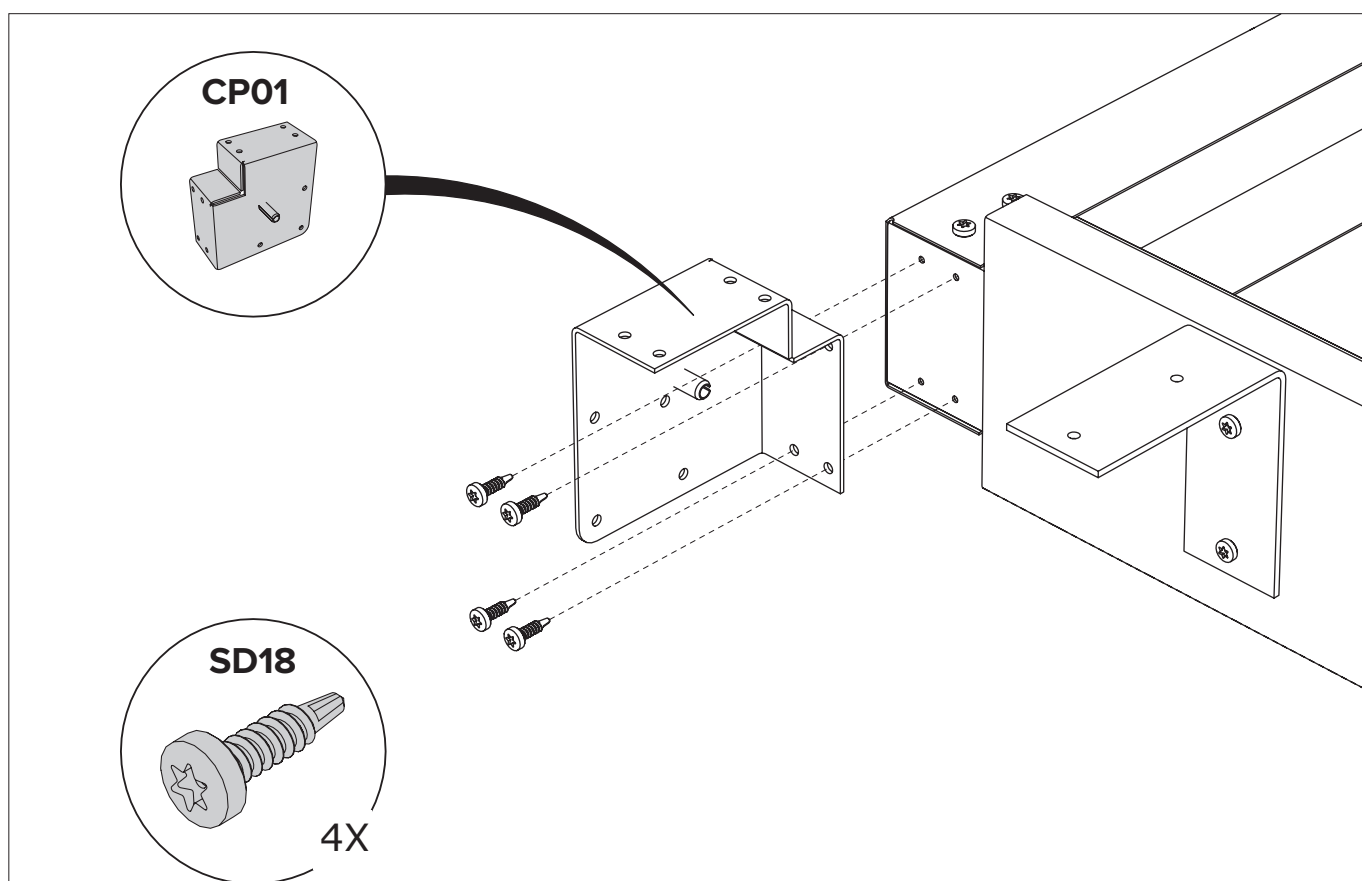

CP01

SD18

4X

C

Fachada / Fachada

POW

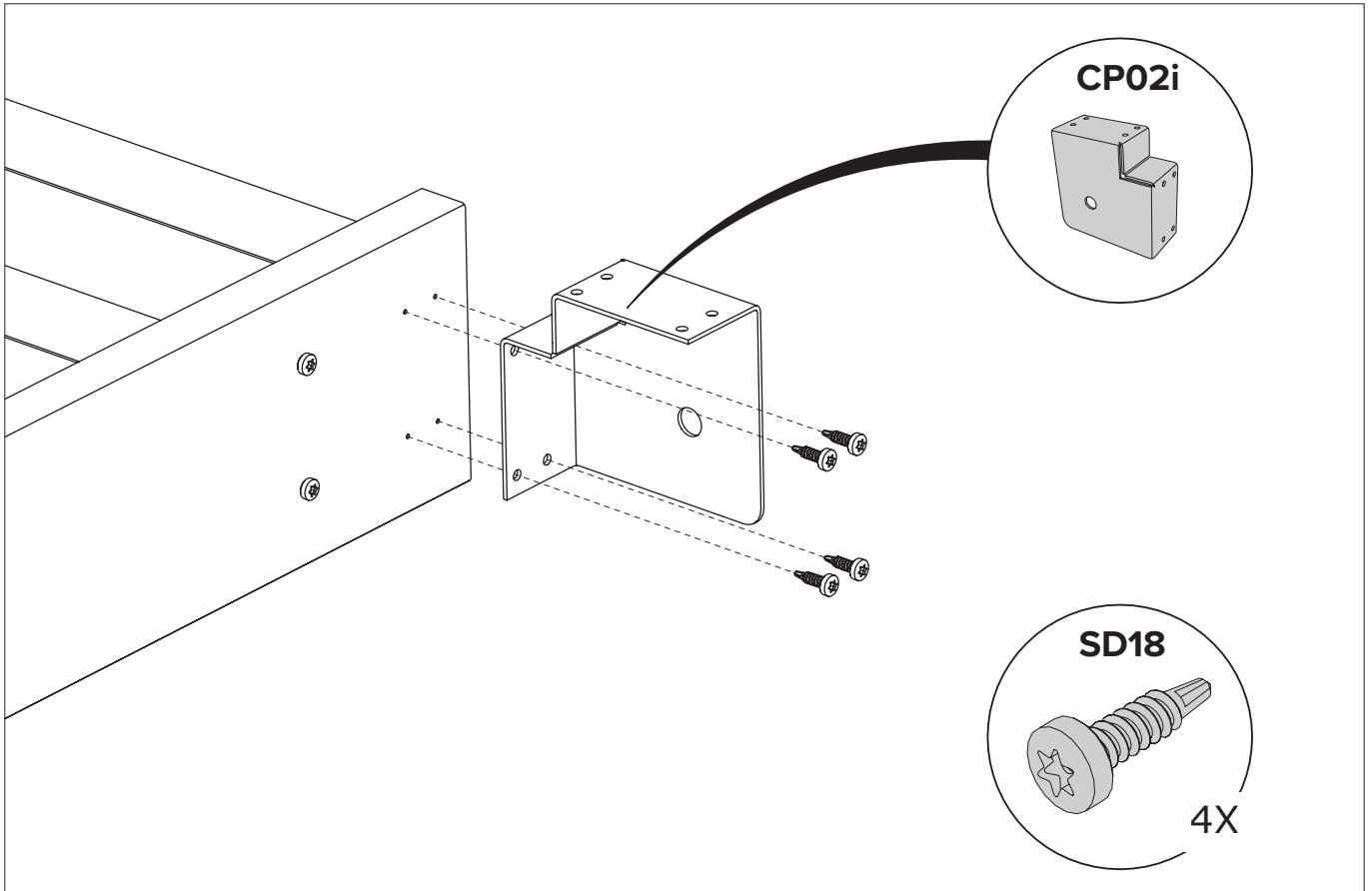

C Fachada / Fachada

POW

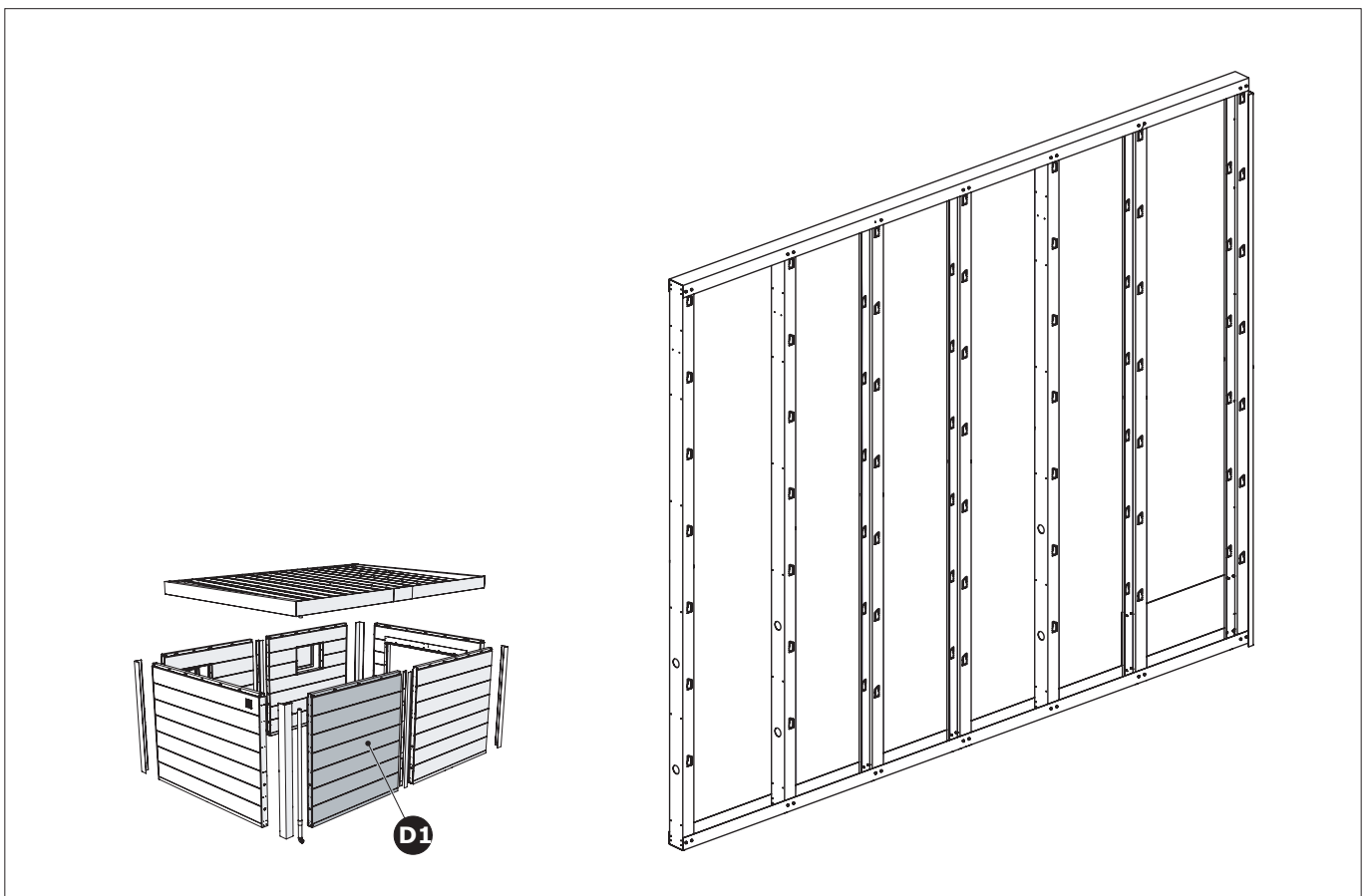

D1 Fachada / Fachada

O princípio da construção da fachada, ver páginas 9 a 15 (POW).
El principio de la construcción de la fachada, ver paginas 9 a 15 (POW).

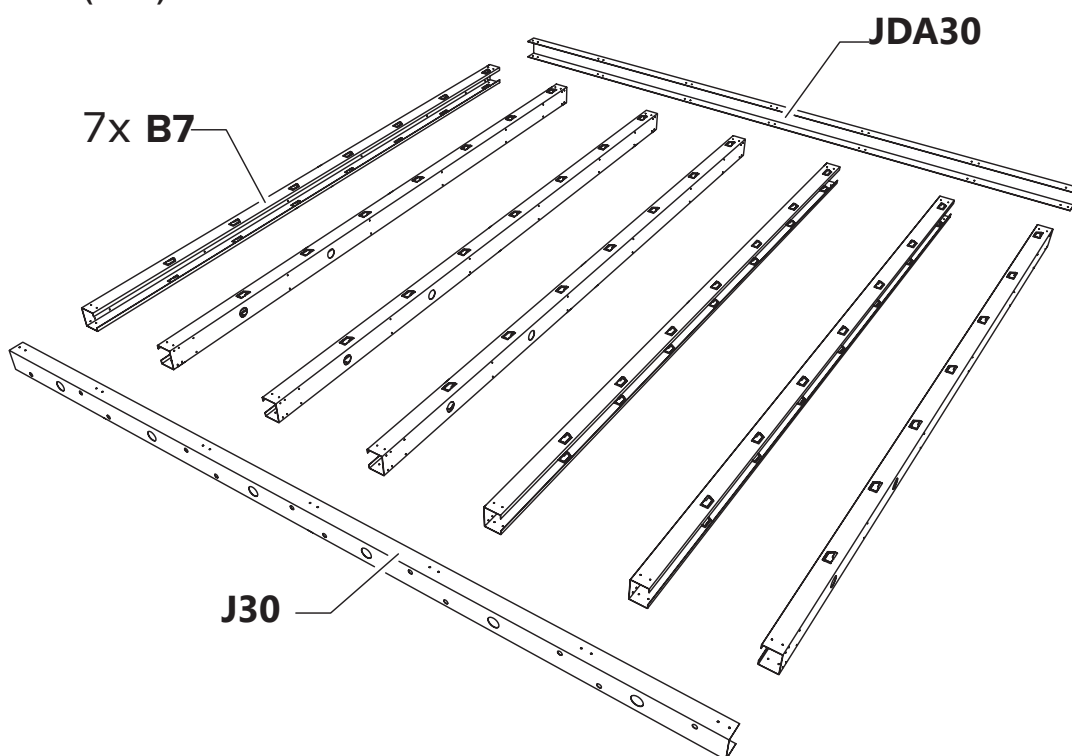

D1 Fachada / Fachada

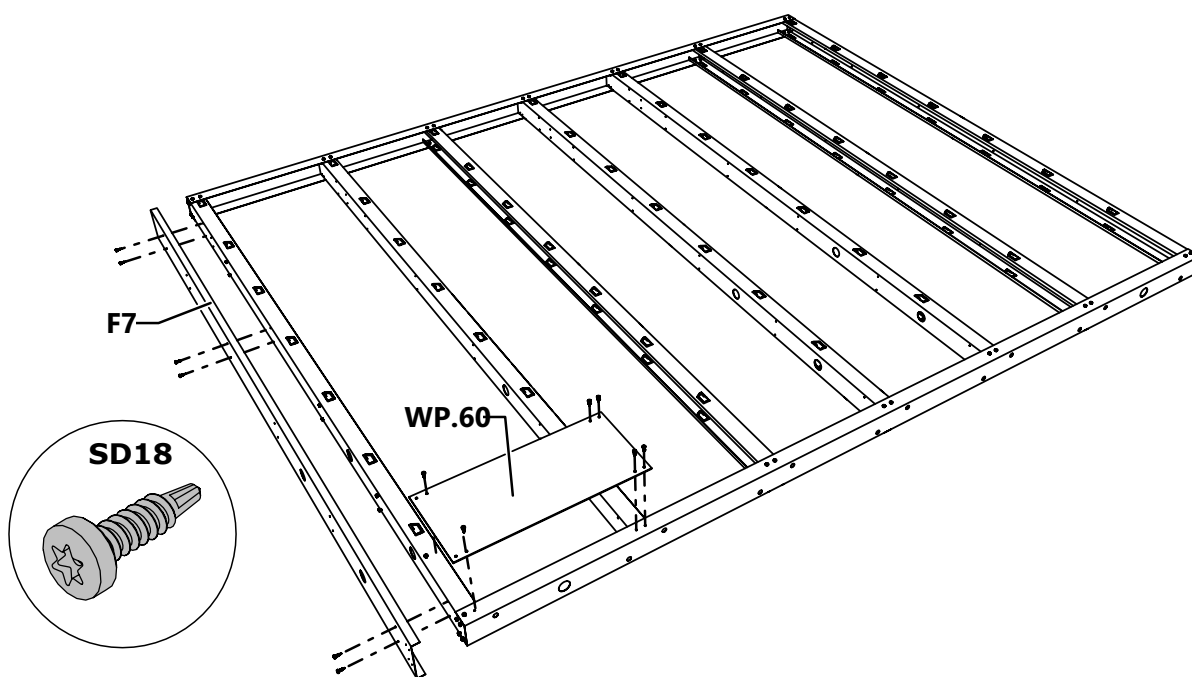

D1 Fachada / Fachada

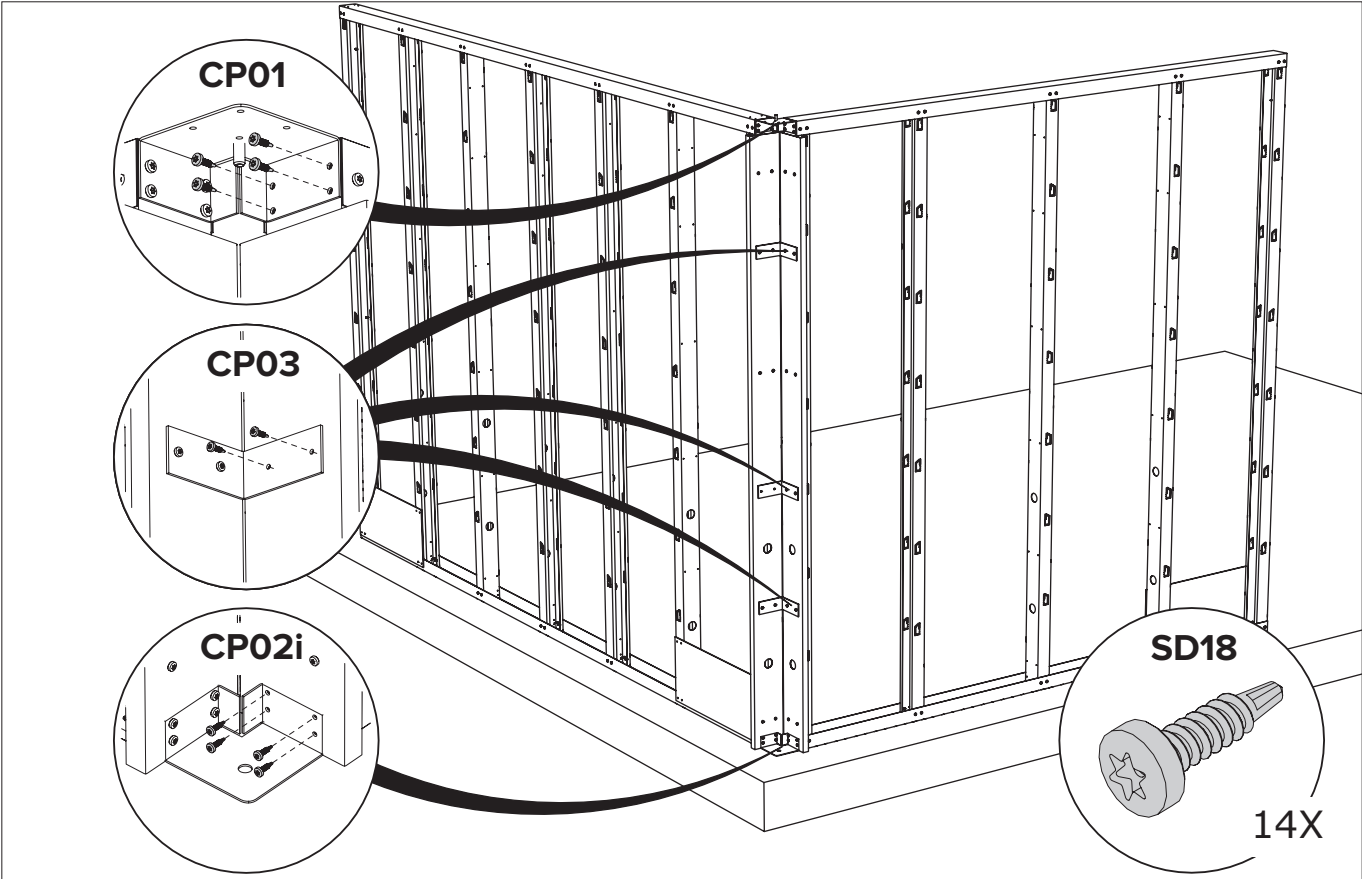

C/D1 Fachada / Fachada

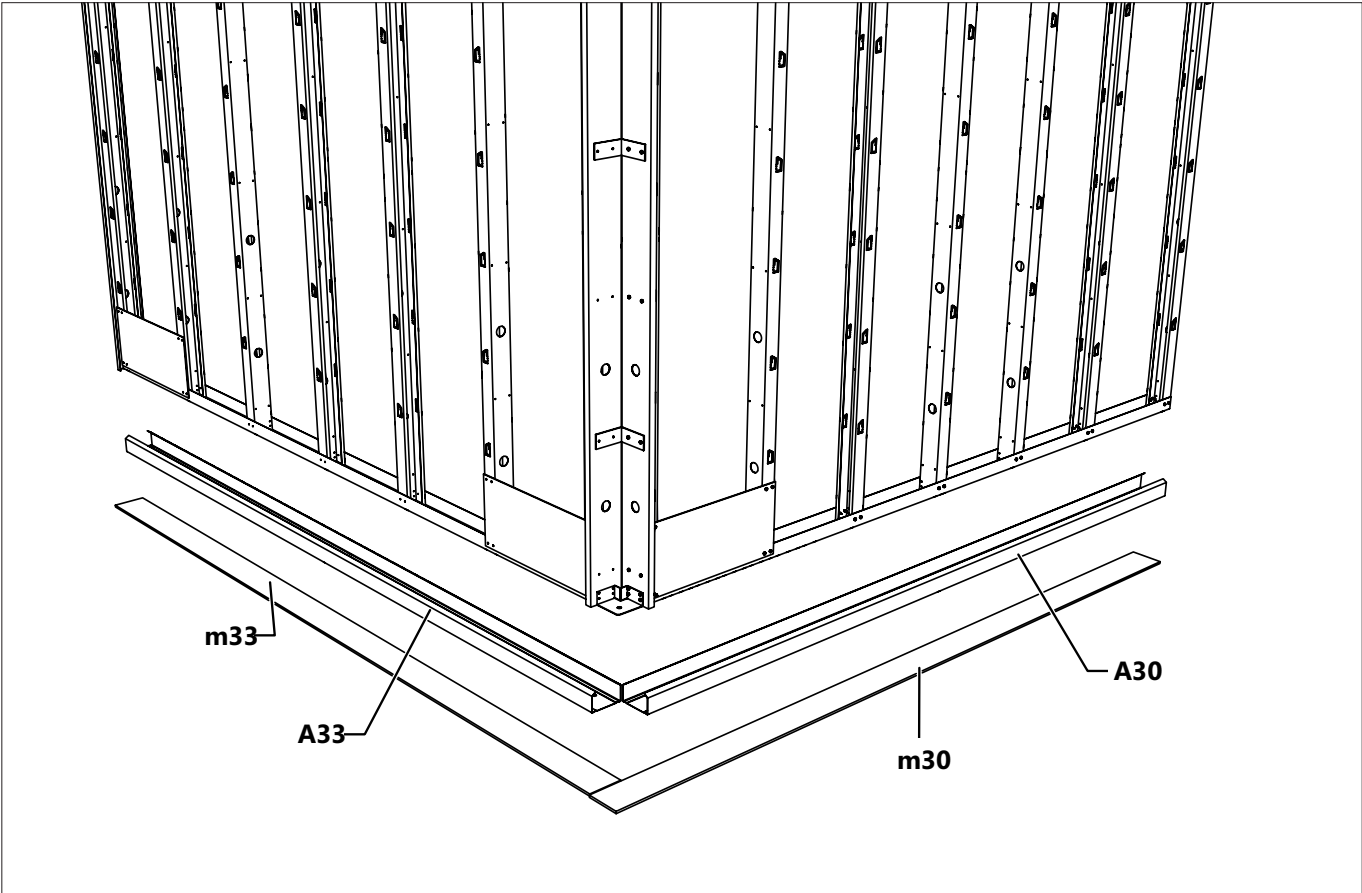

C/D1 Fachada / Fachada

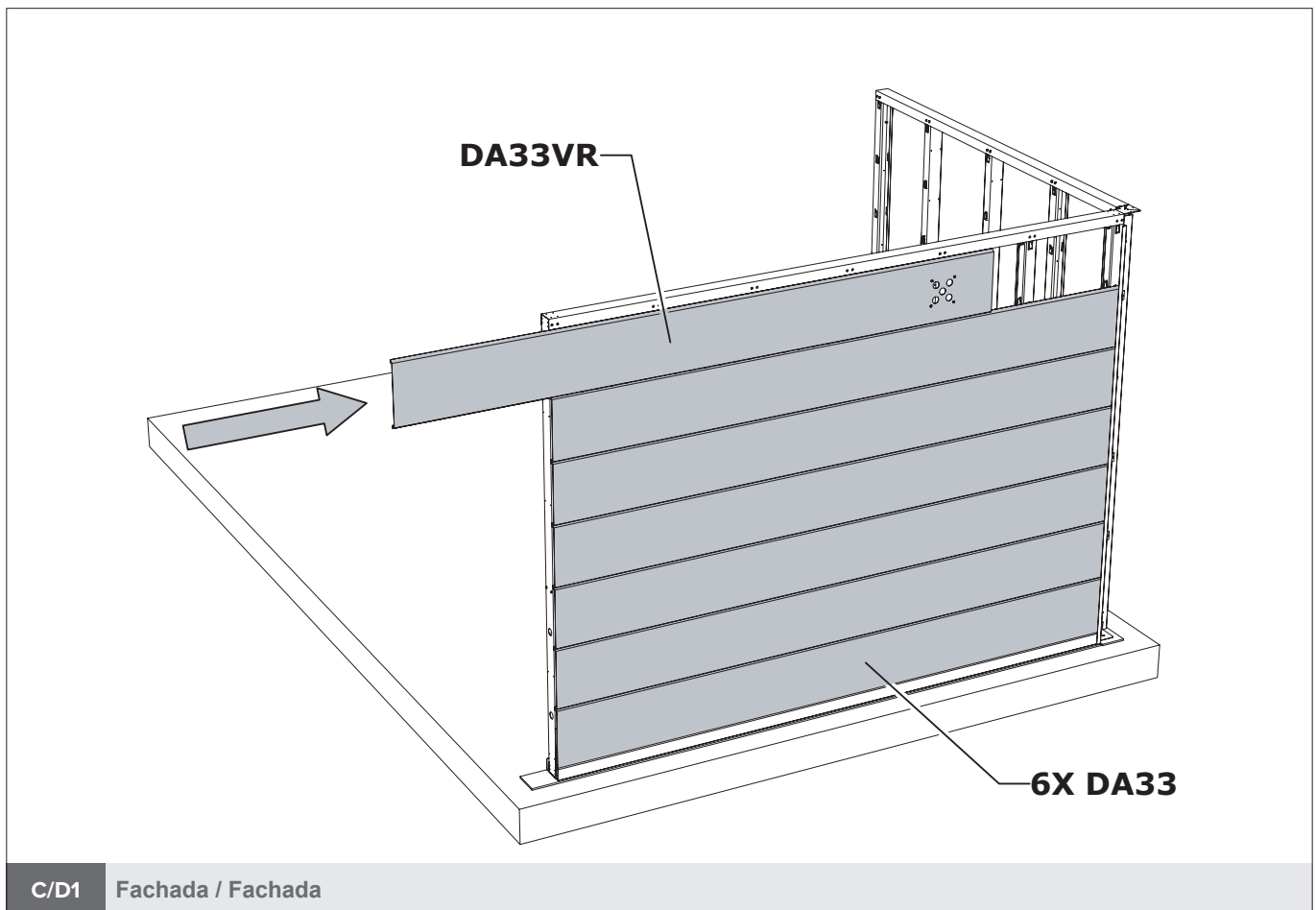
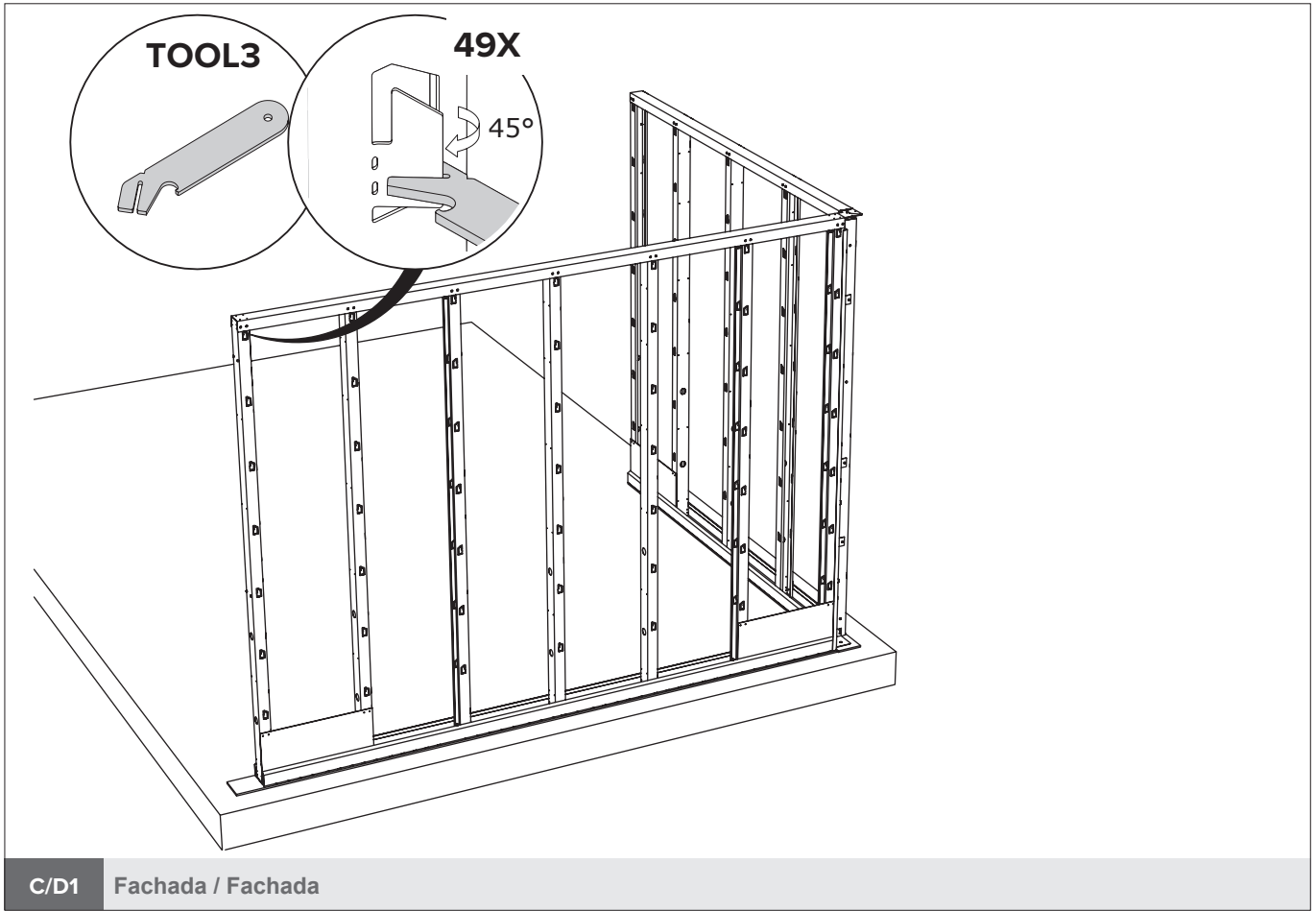

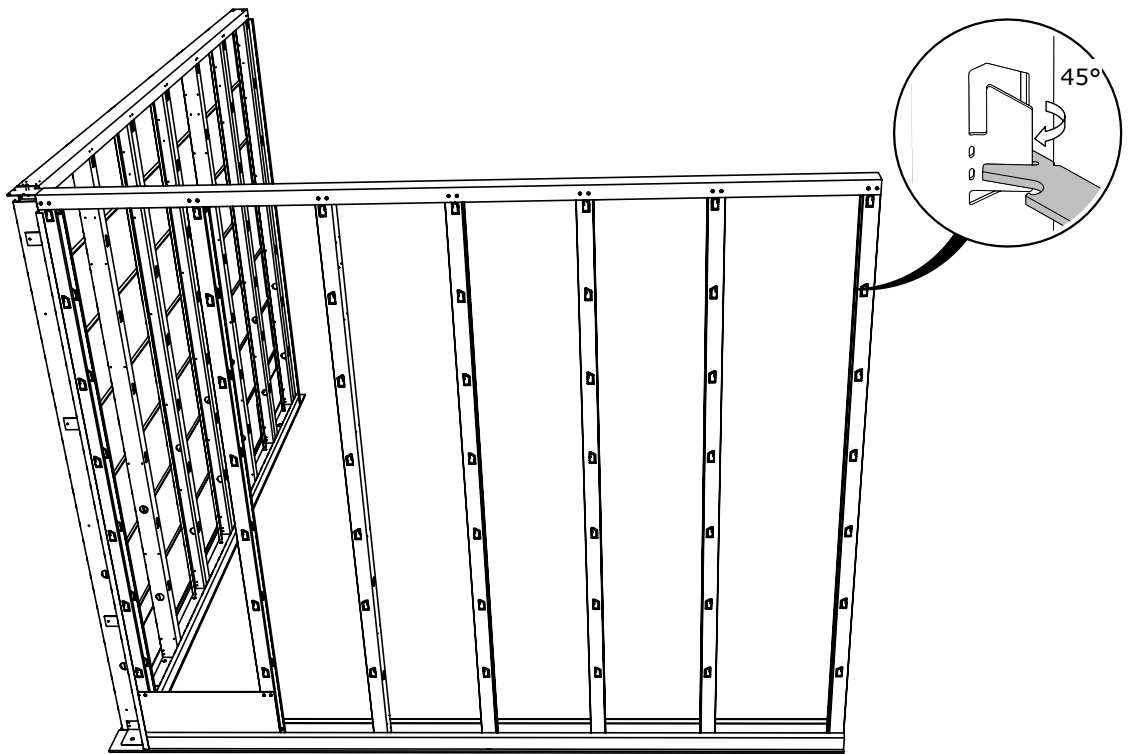

C/D1 Fachada / Fachada

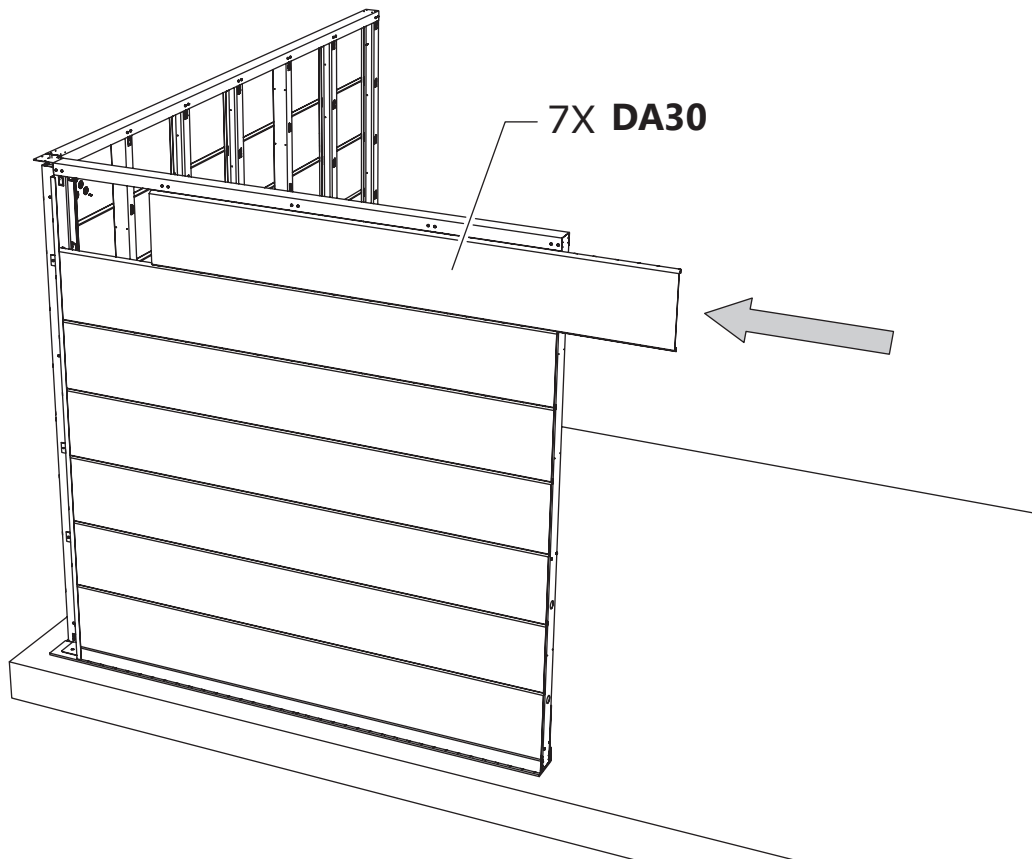

C/D1 Fachada / Fachada

Revestimento interior
Revestimiento interior

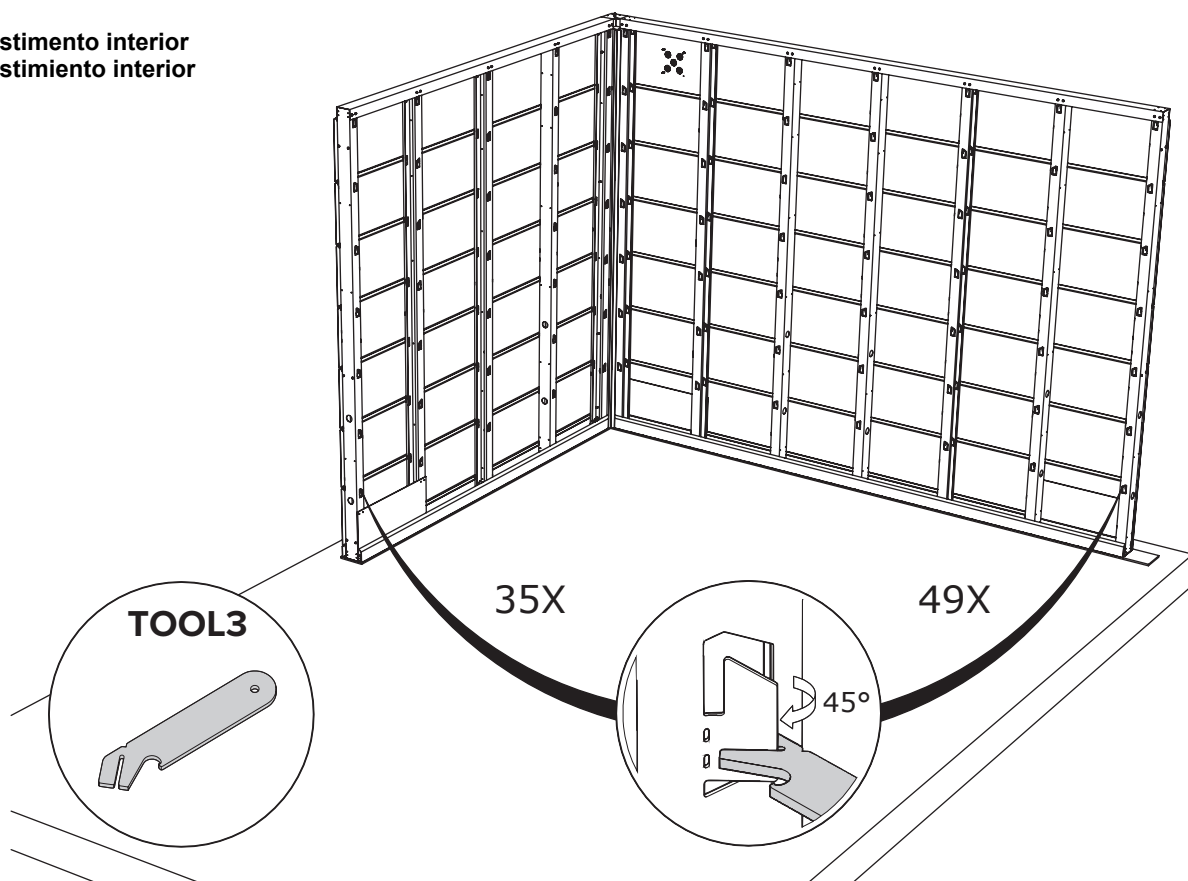

C/D1 Fachada / Fachada

7X DI30

DI33V

6X DI33

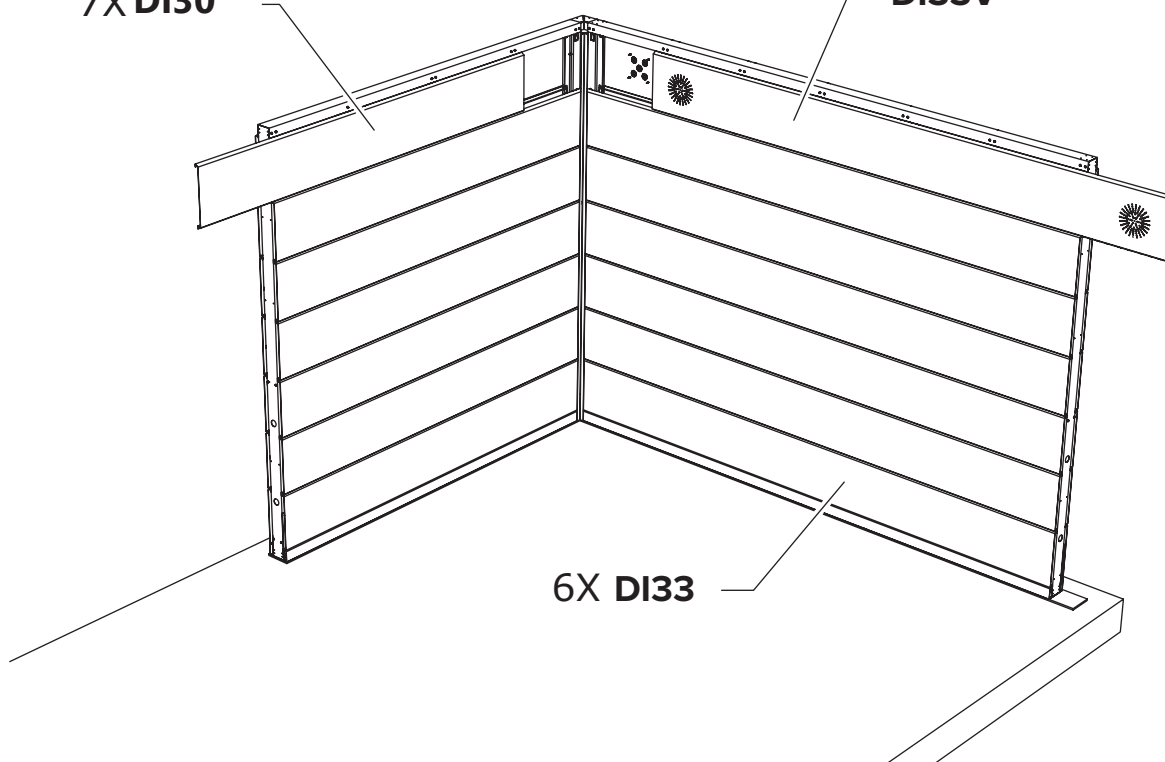

C/D1 Fachada / Fachada

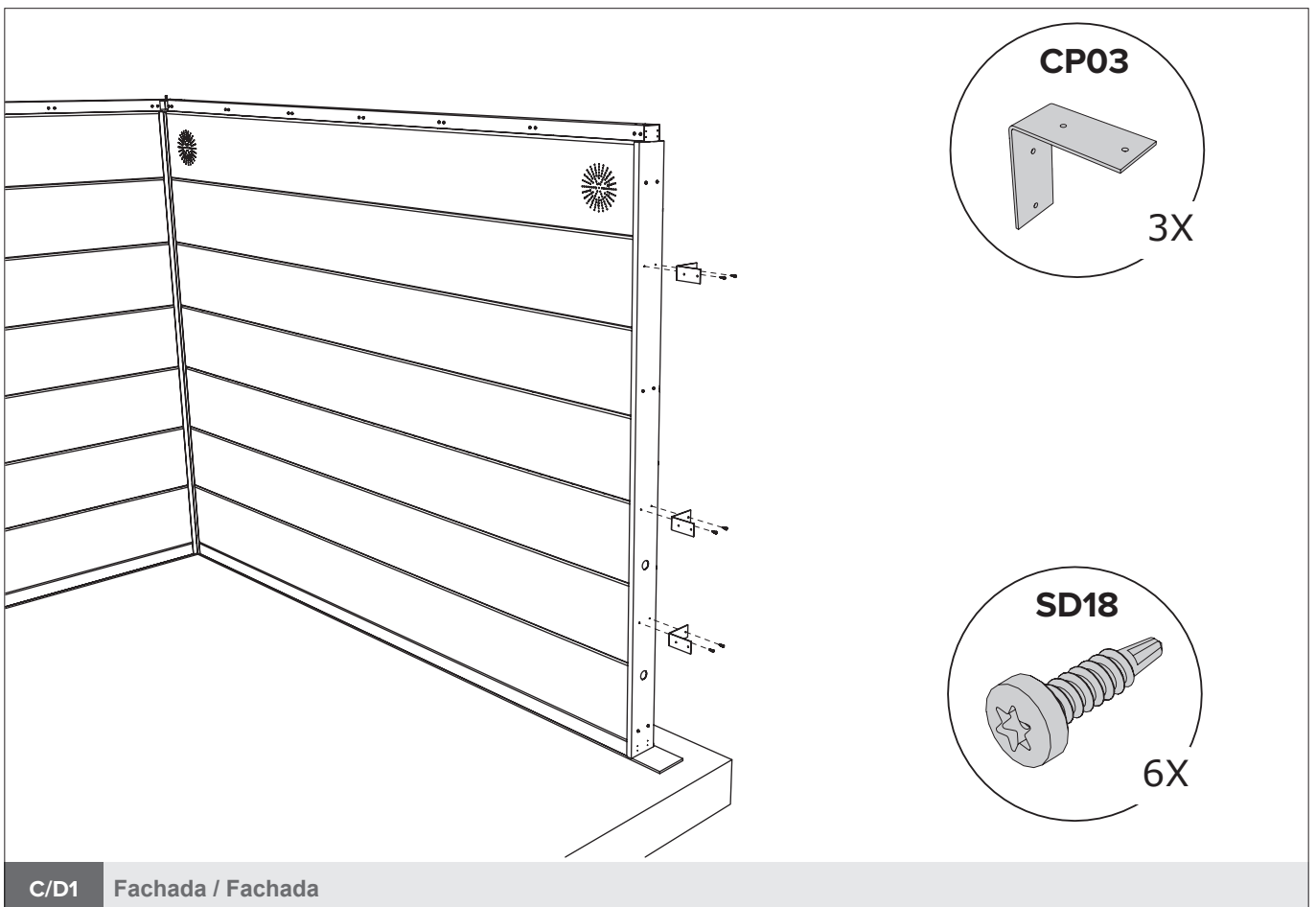
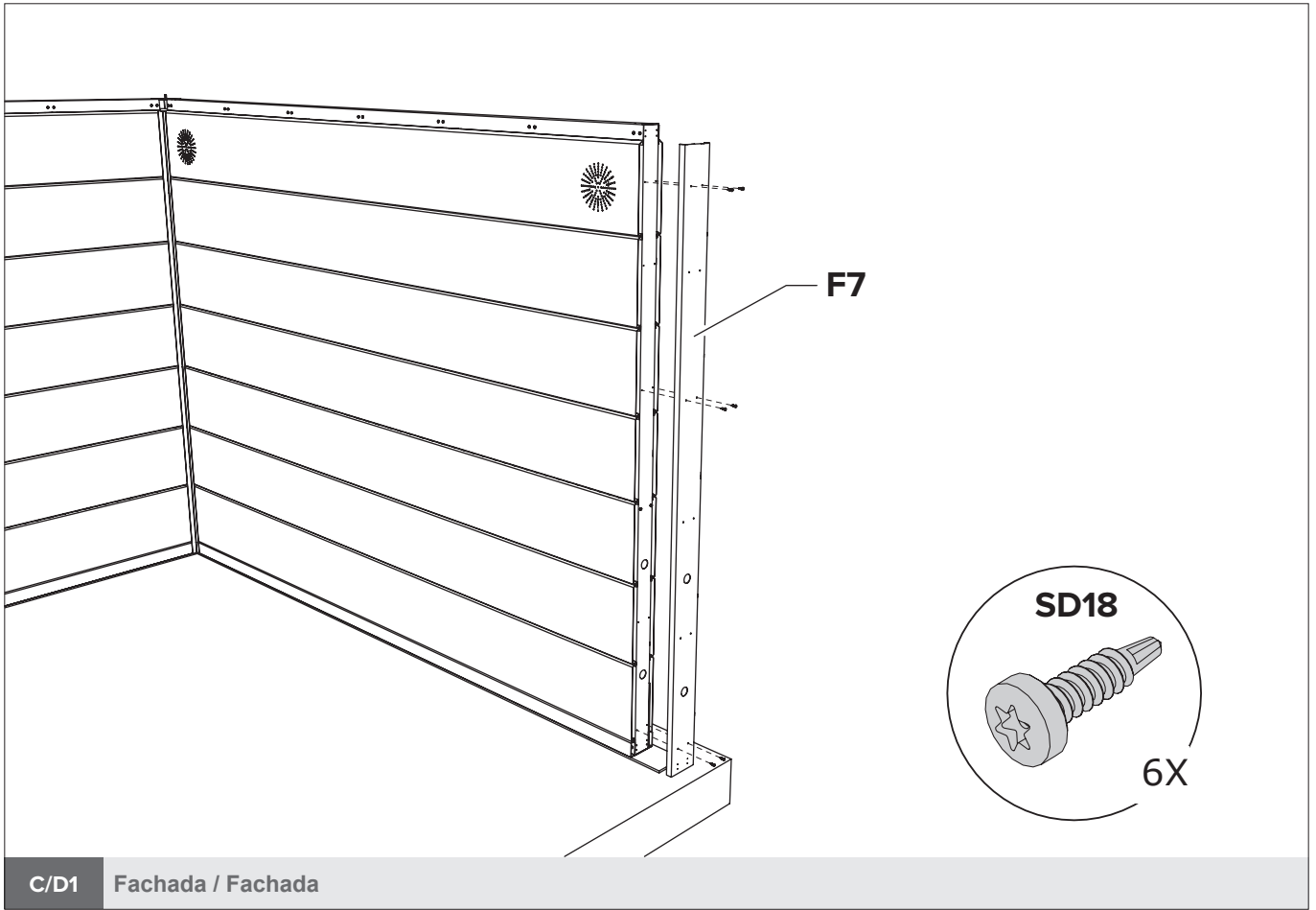

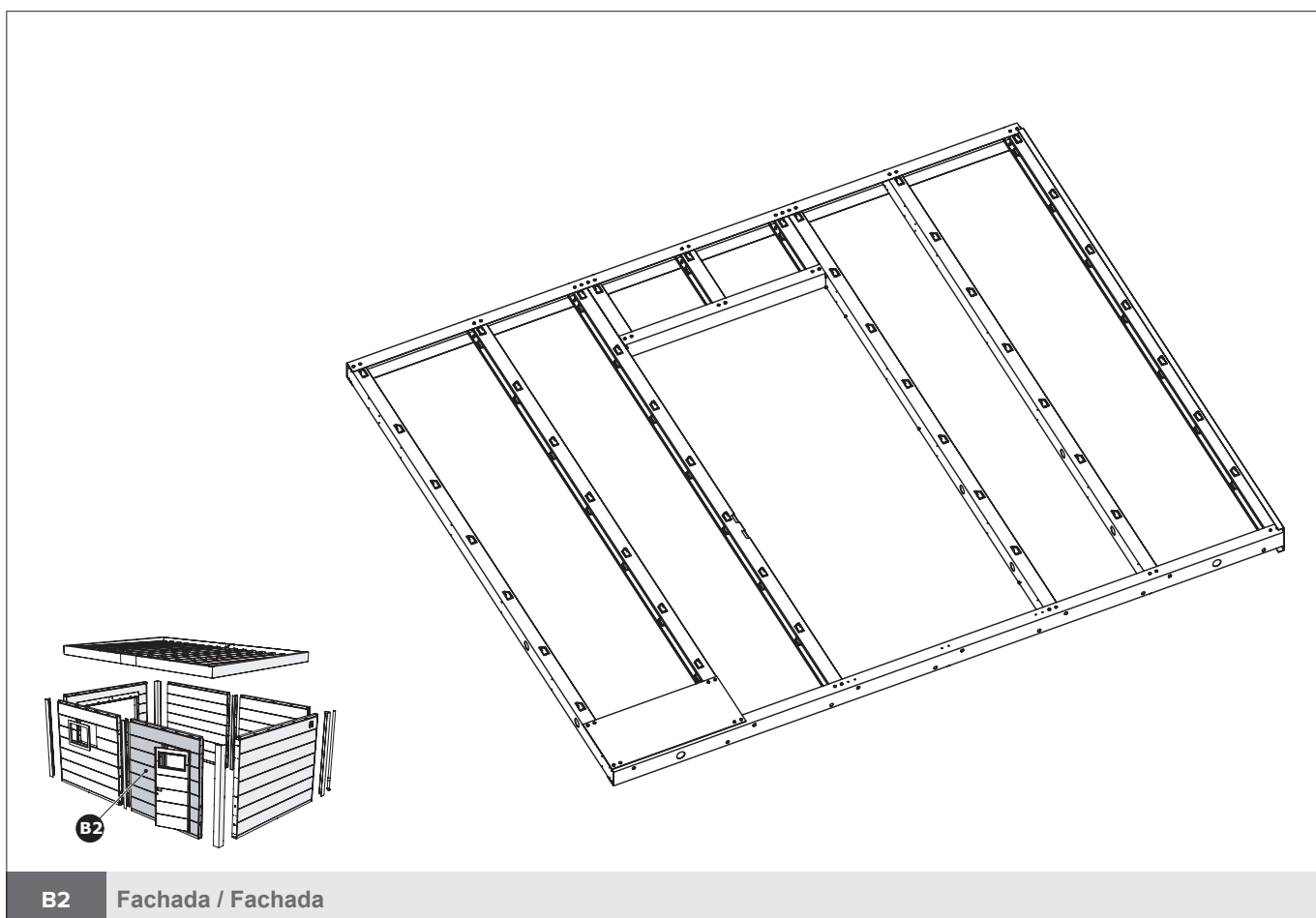
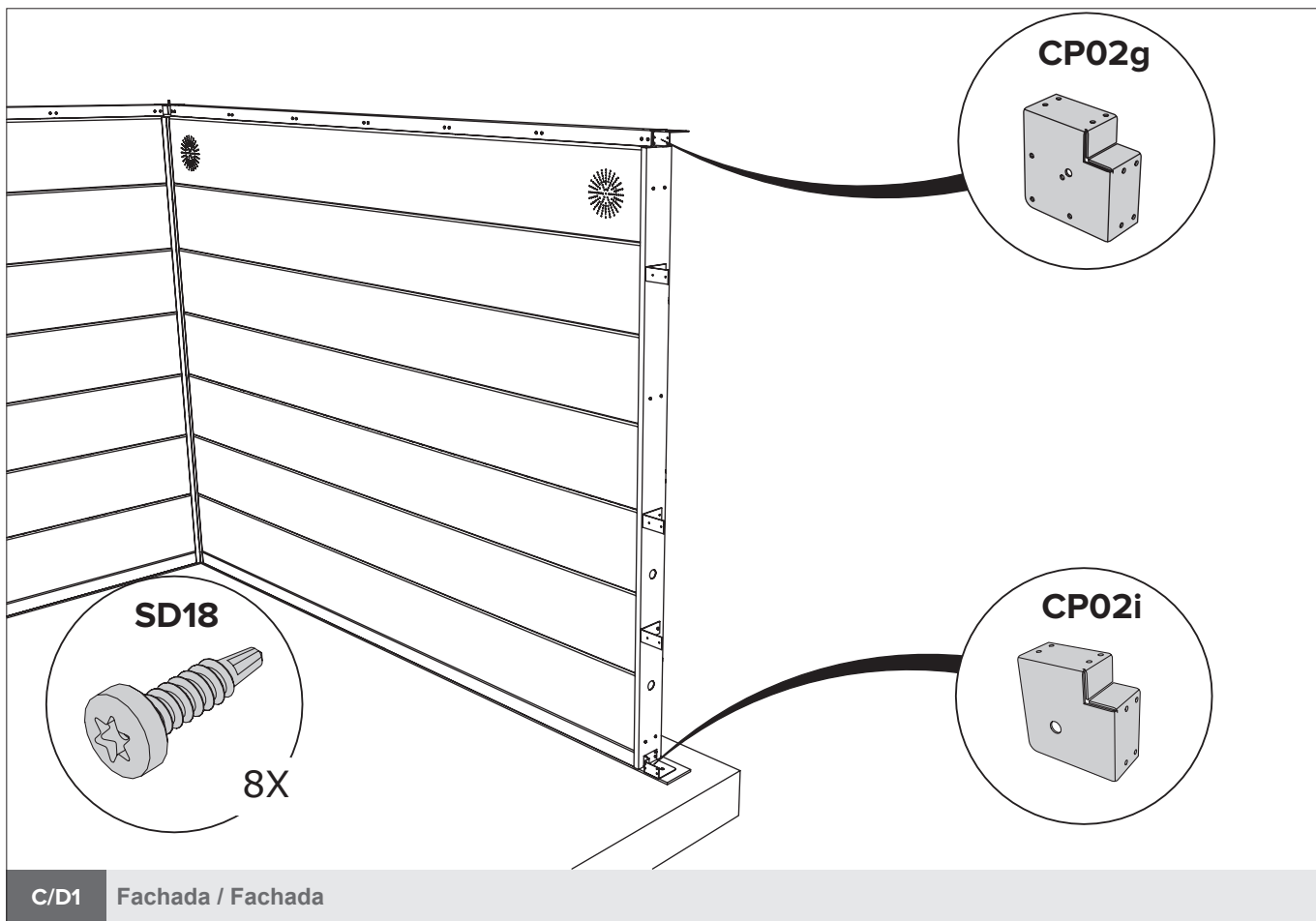

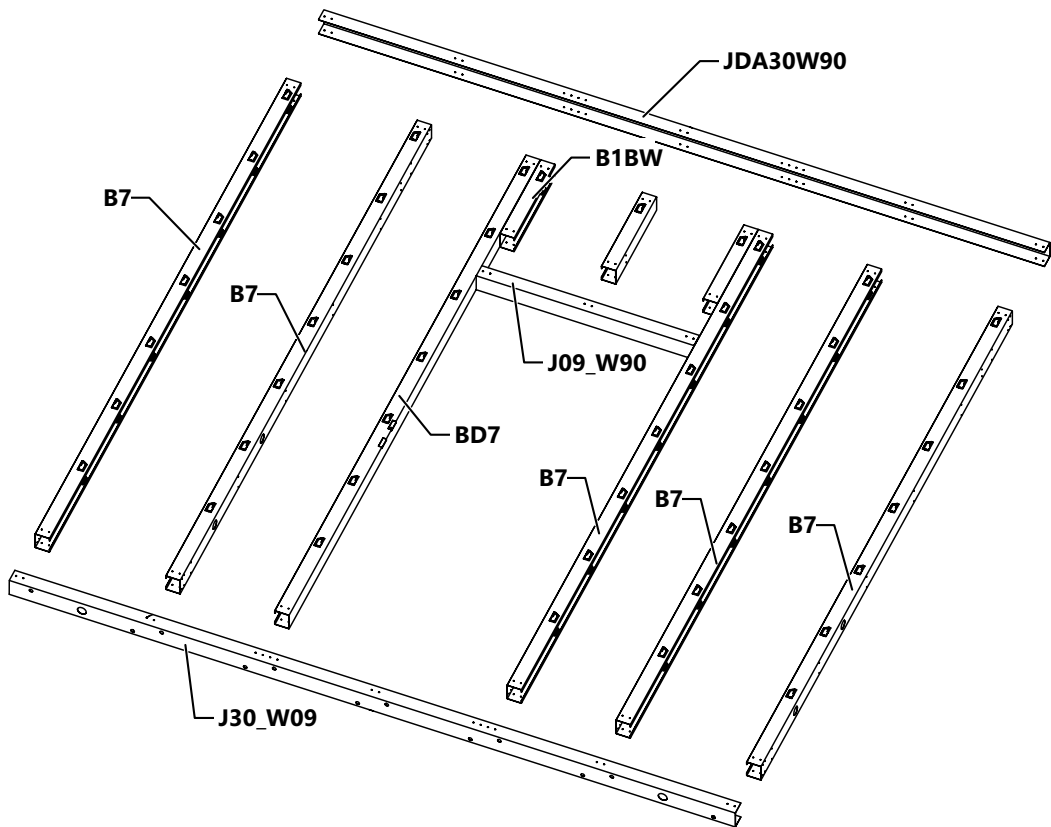

B2 Fachada / Fachada

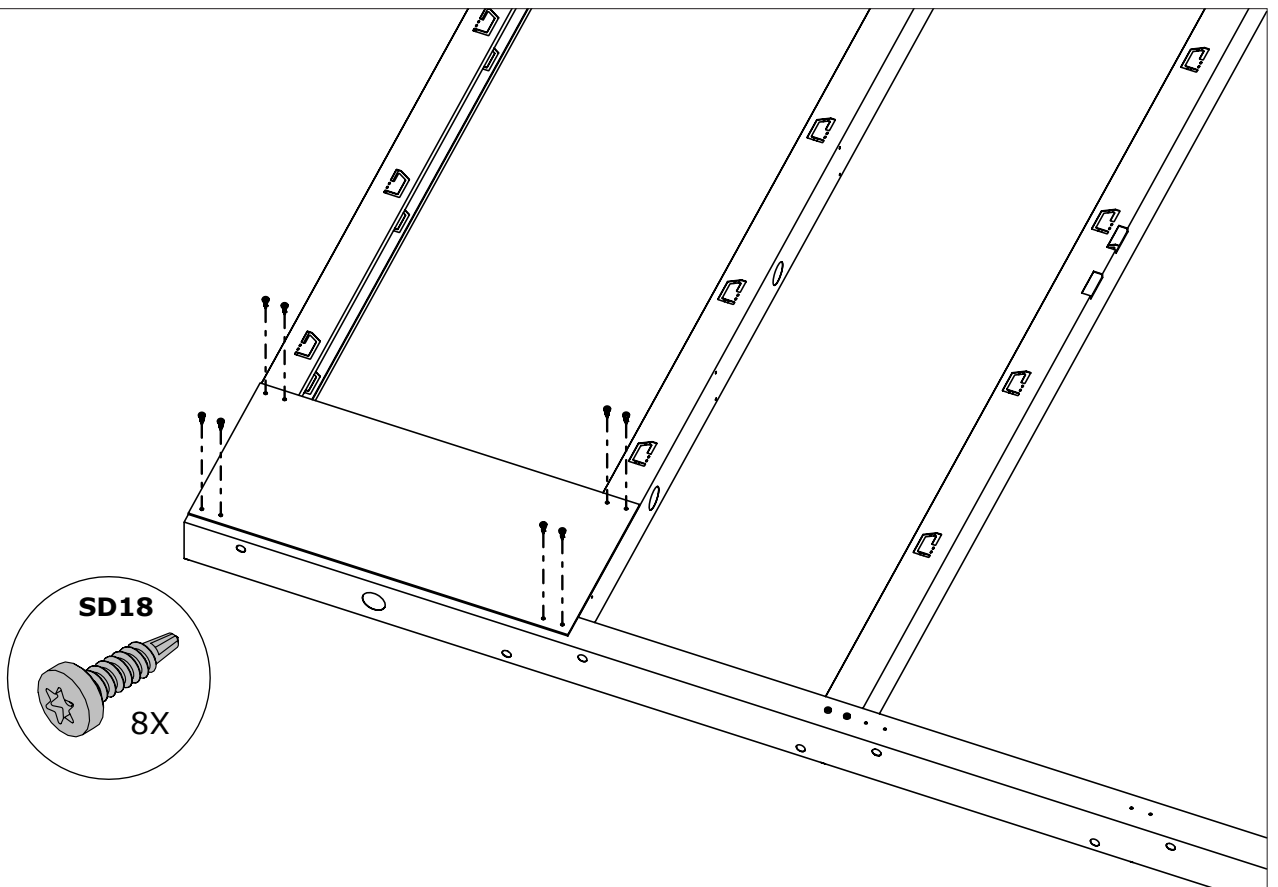

B2 Fachada / Fachada

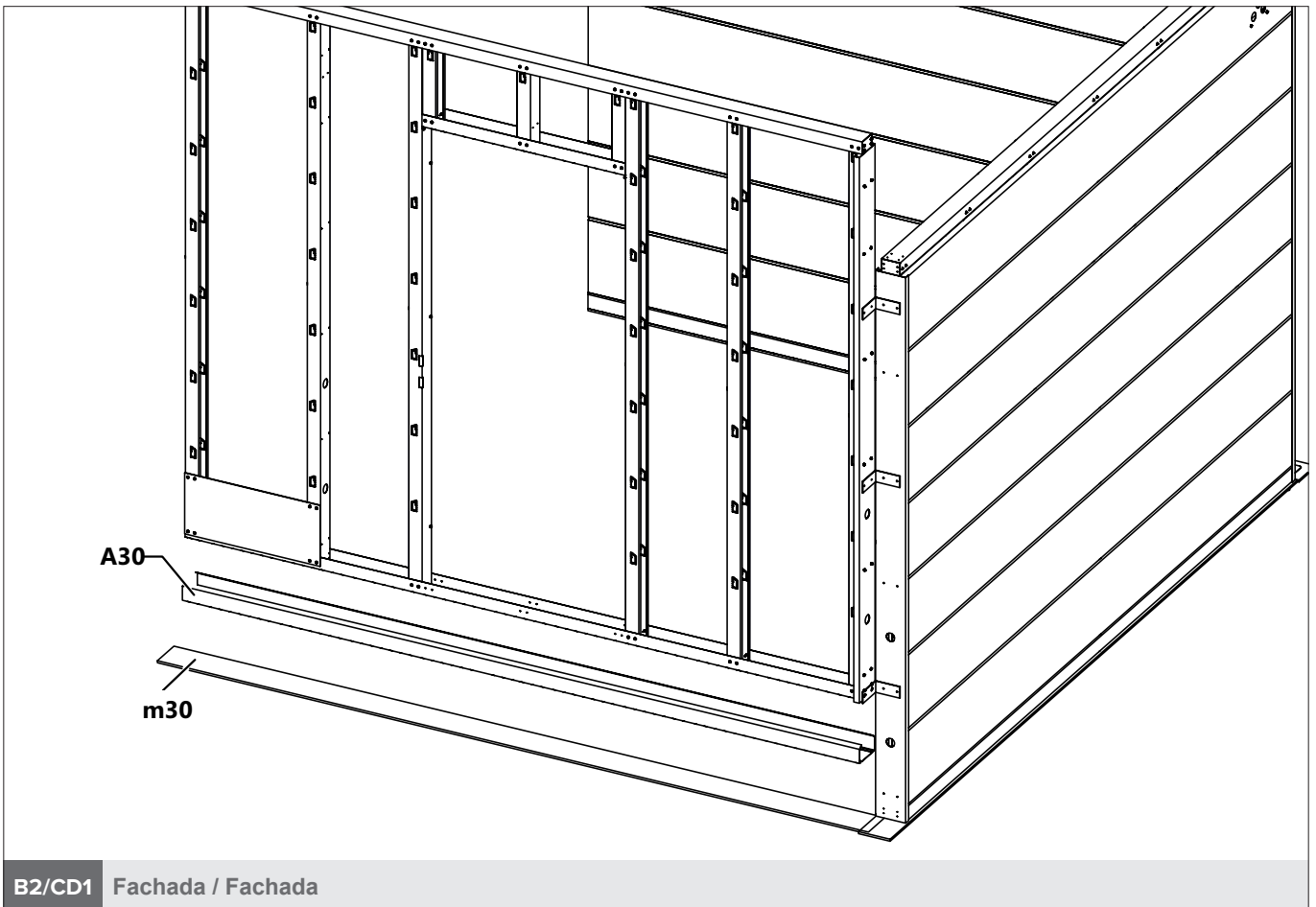
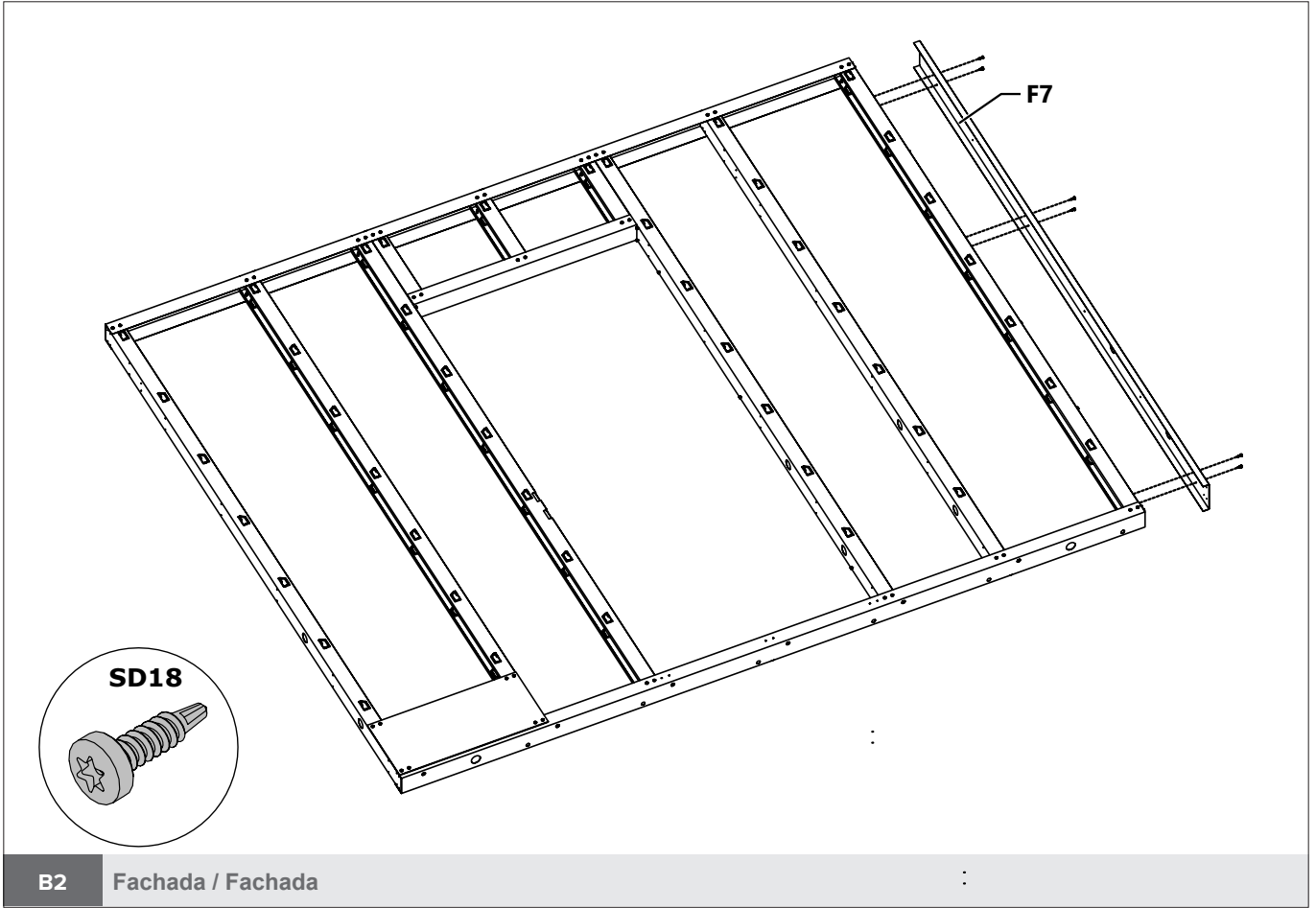

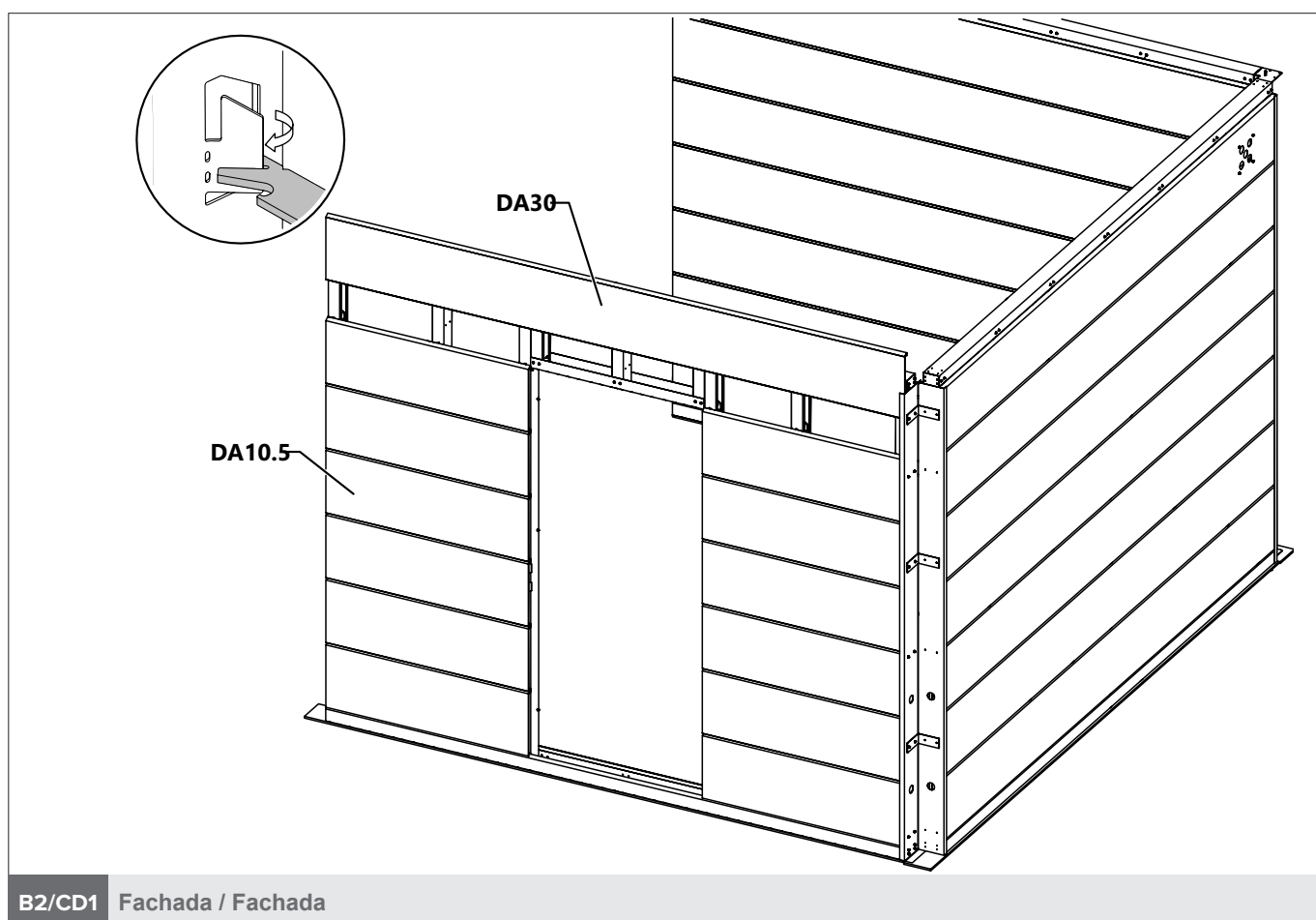
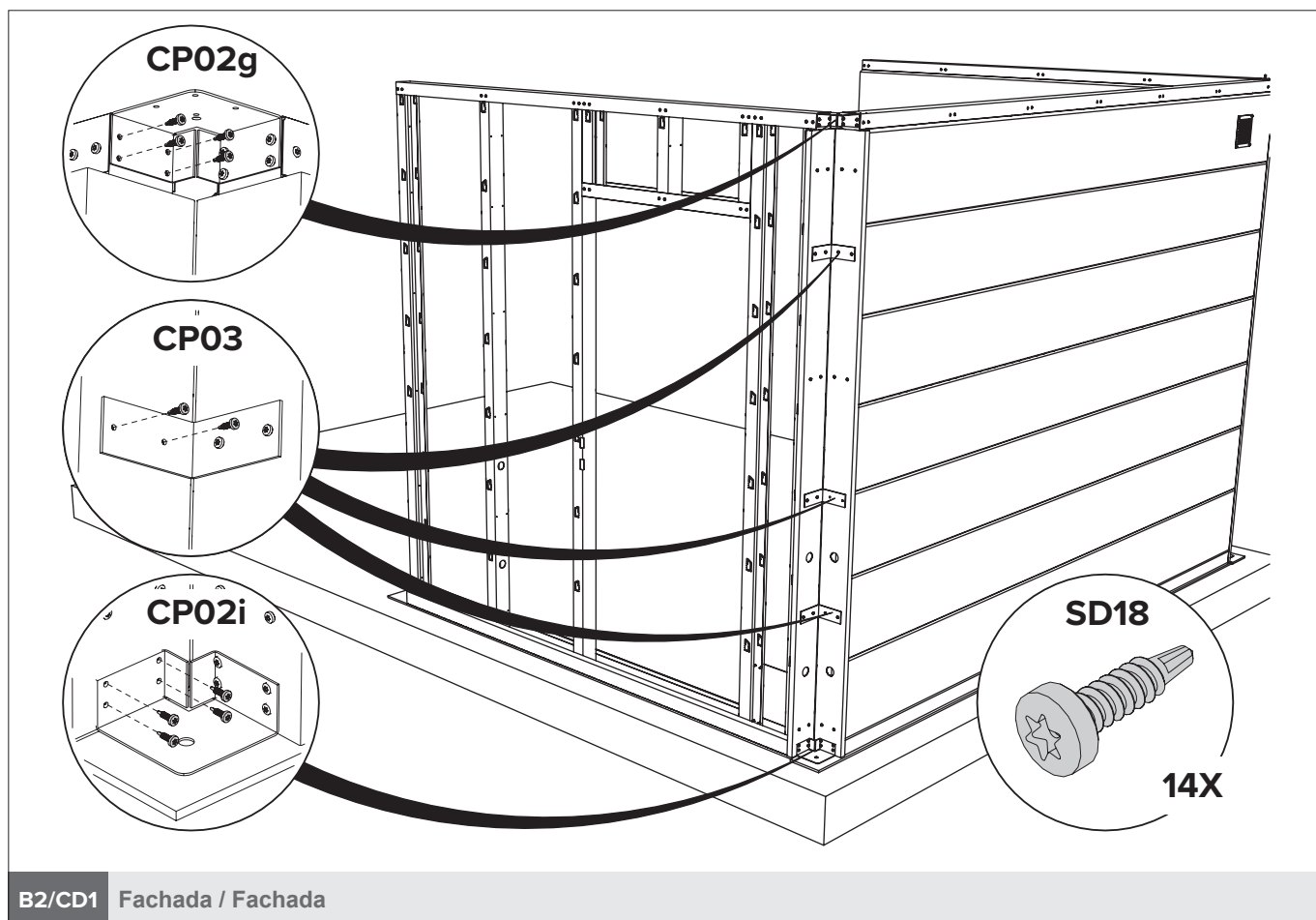

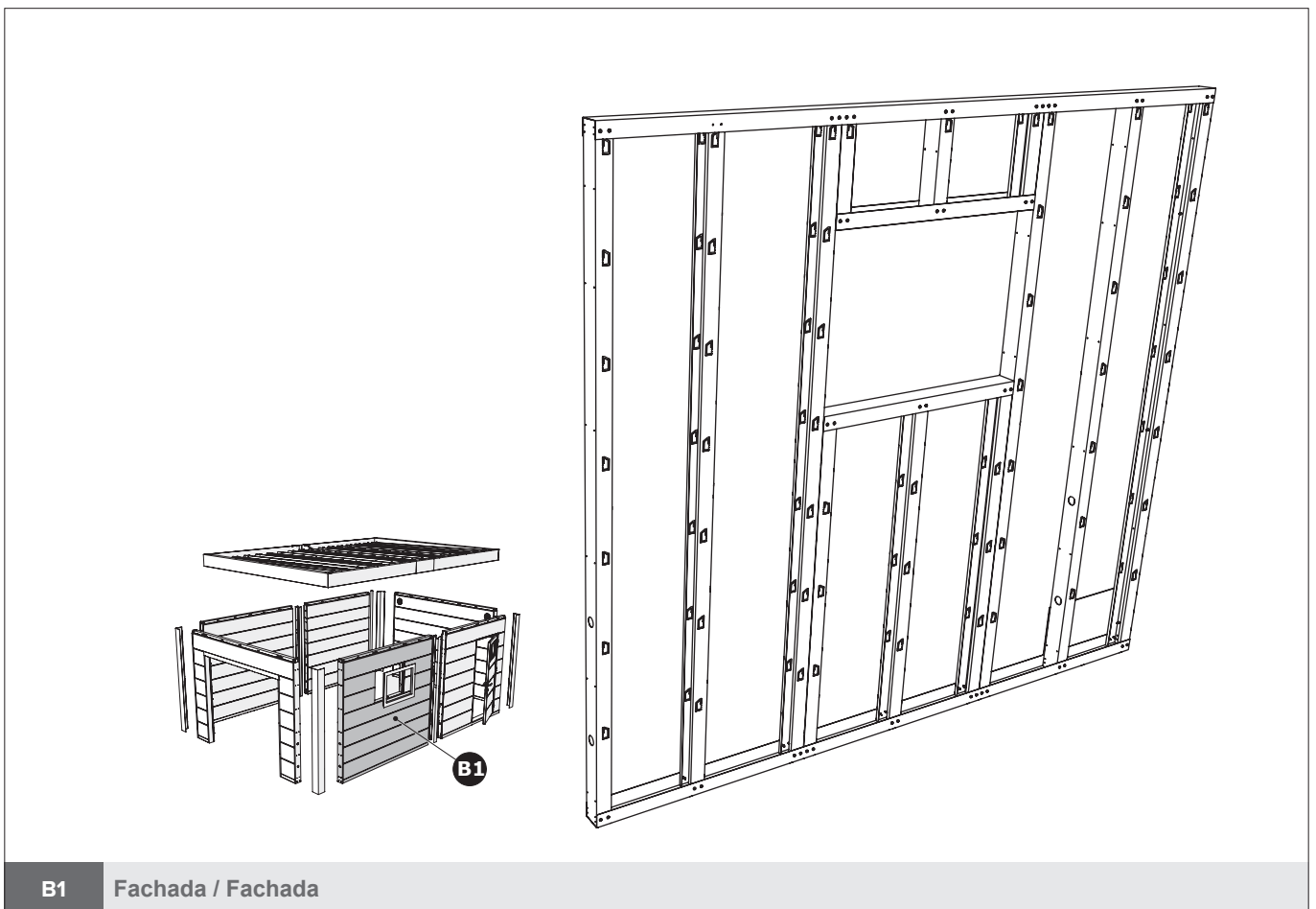
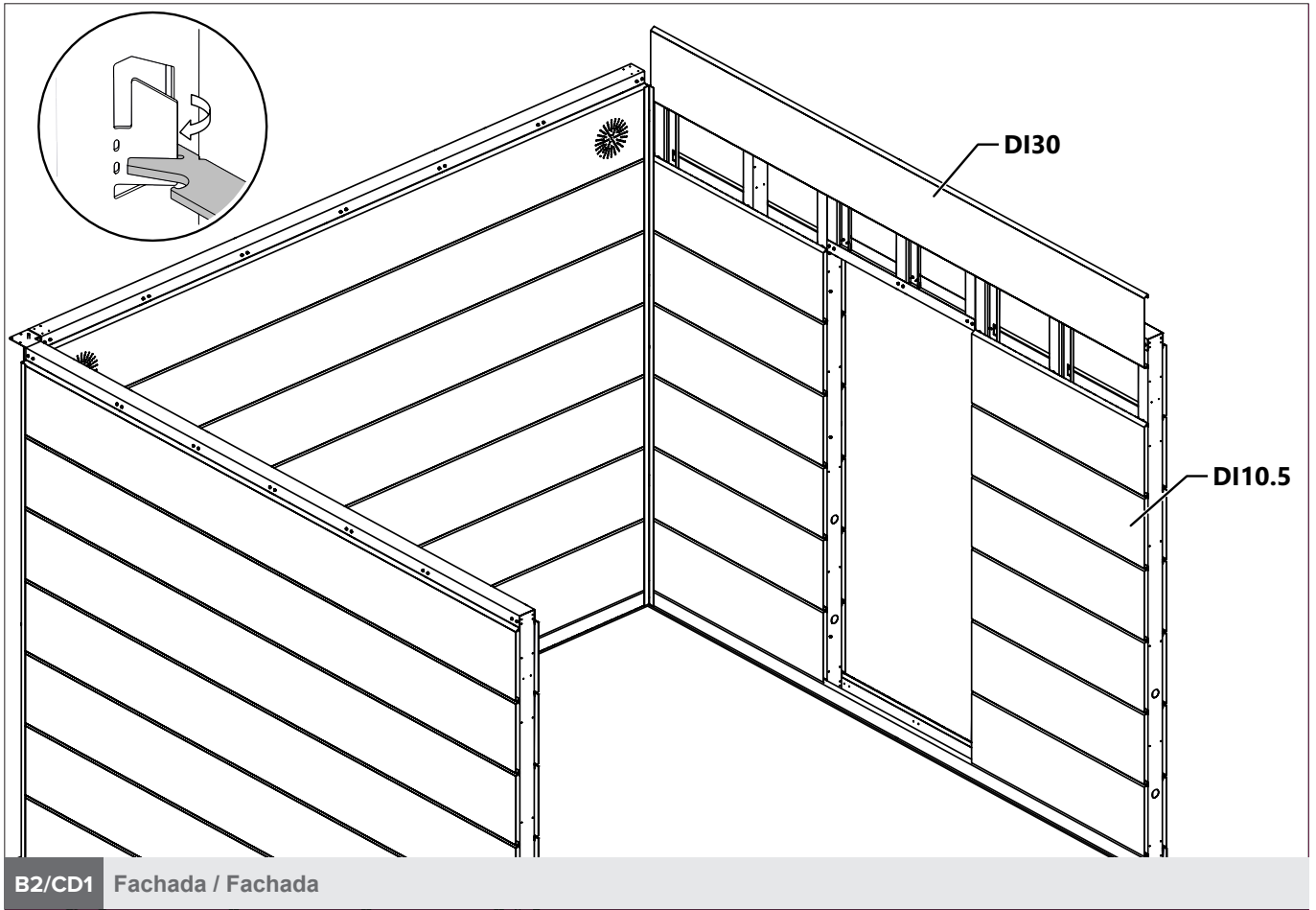

O princípio da construção da fachada, ver páginas 9 a 15 (POW).
El principio de la construcción de la fachada, ver paginas 9 a 15 (POW).

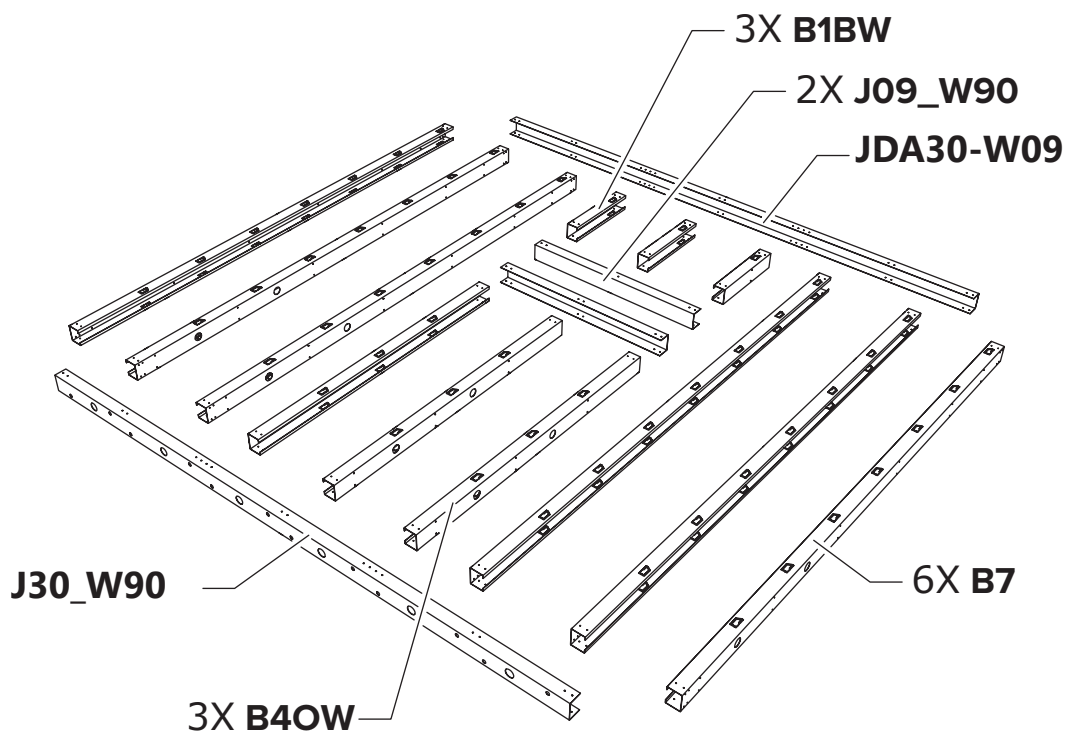

B1 Fachada / Fachada

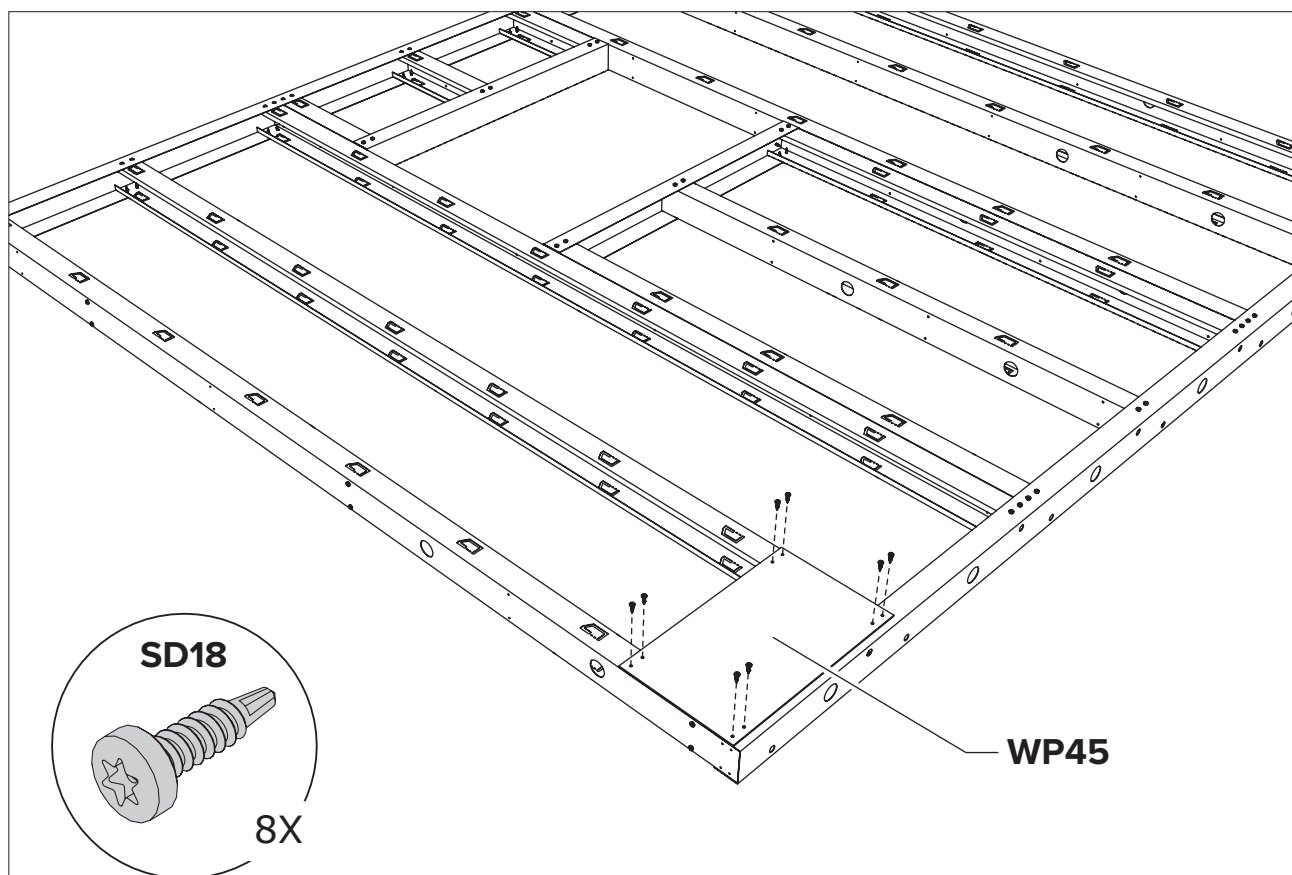

B1 Fachada / Fachada

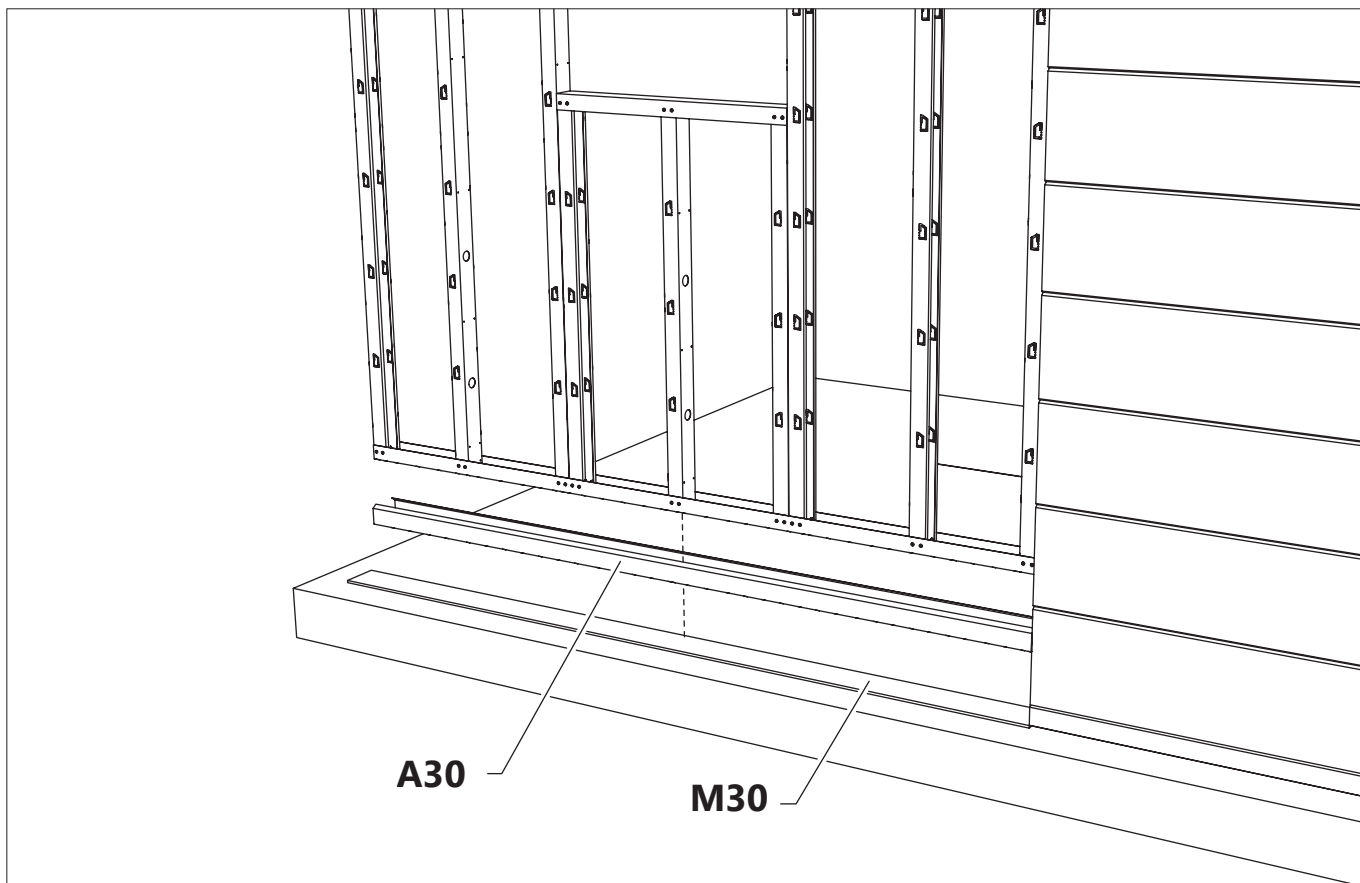

B1/B2/CD1 Fachada / Fachada

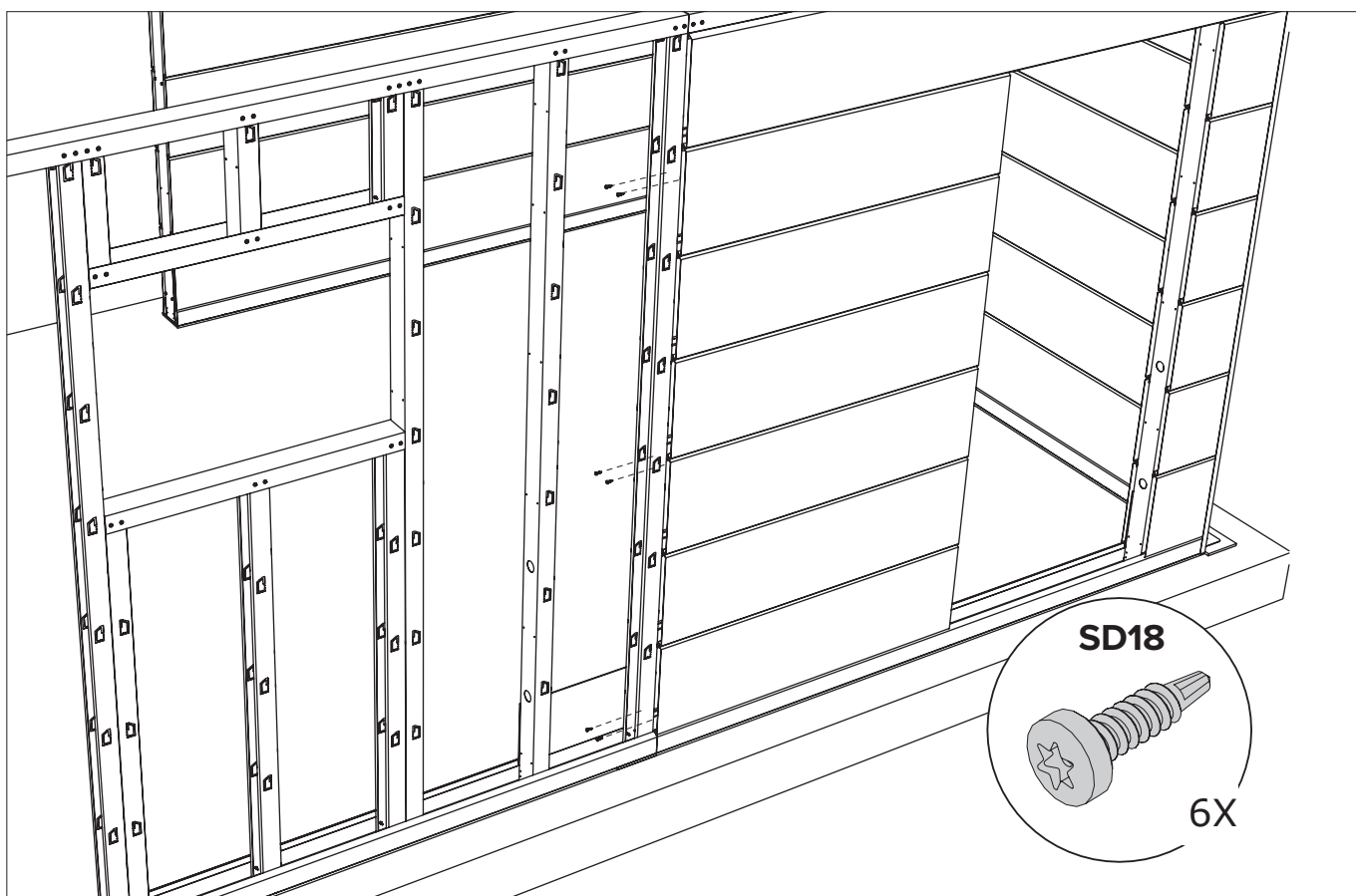

B1/B2/CD1 Fachada / Fachada

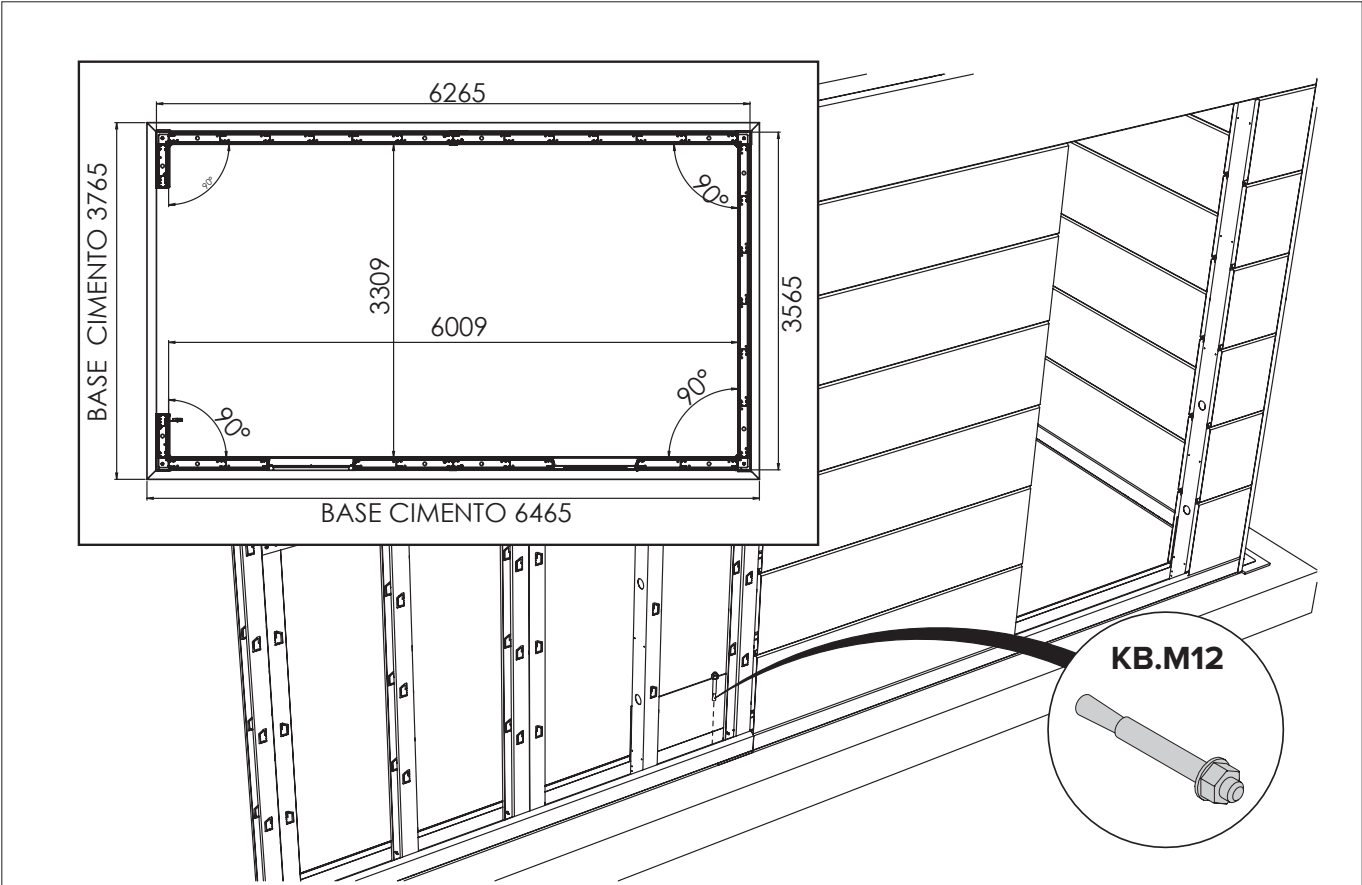

B1/B2/CD1 Fachada / Fachada

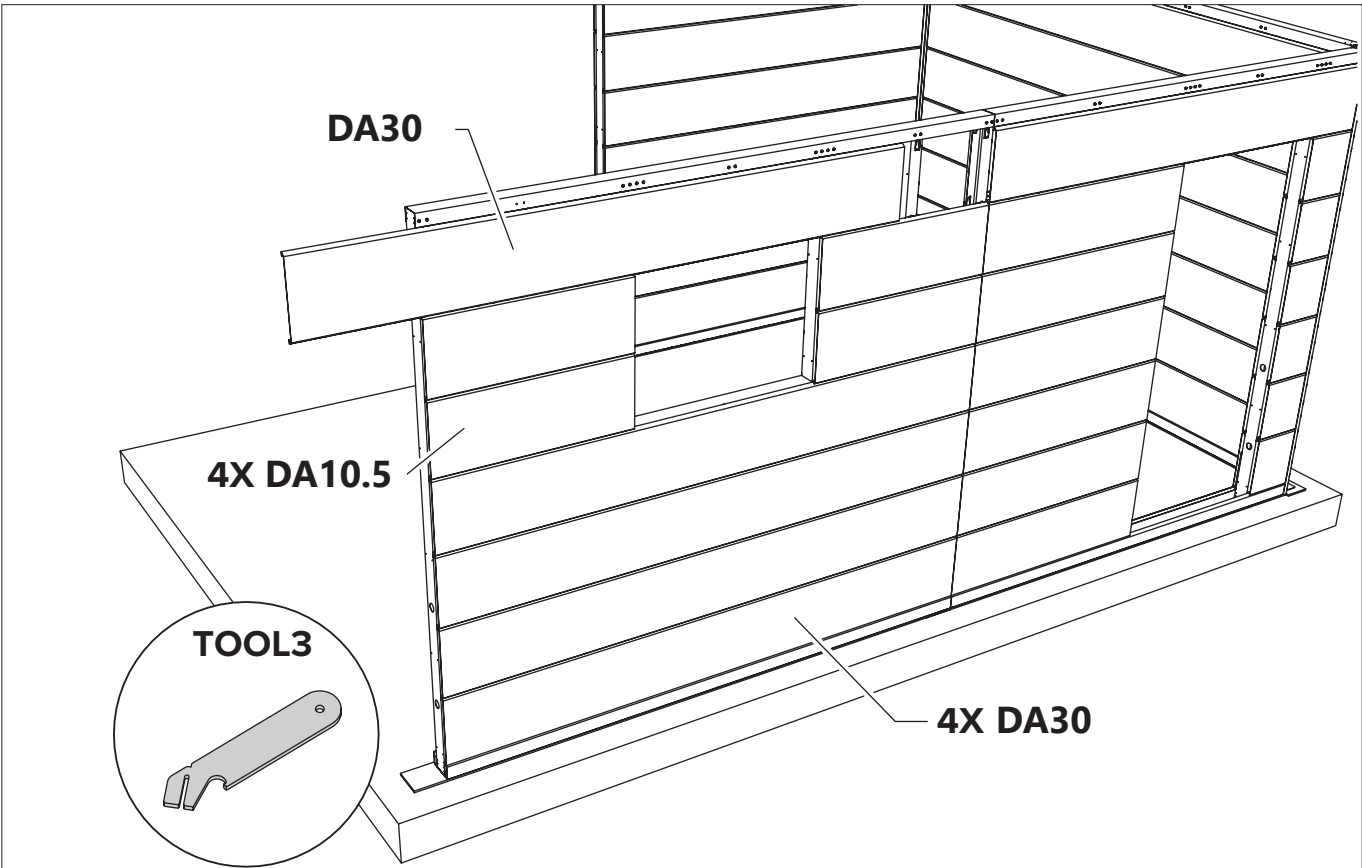

B1/B2/CD1 Fachada / Fachada

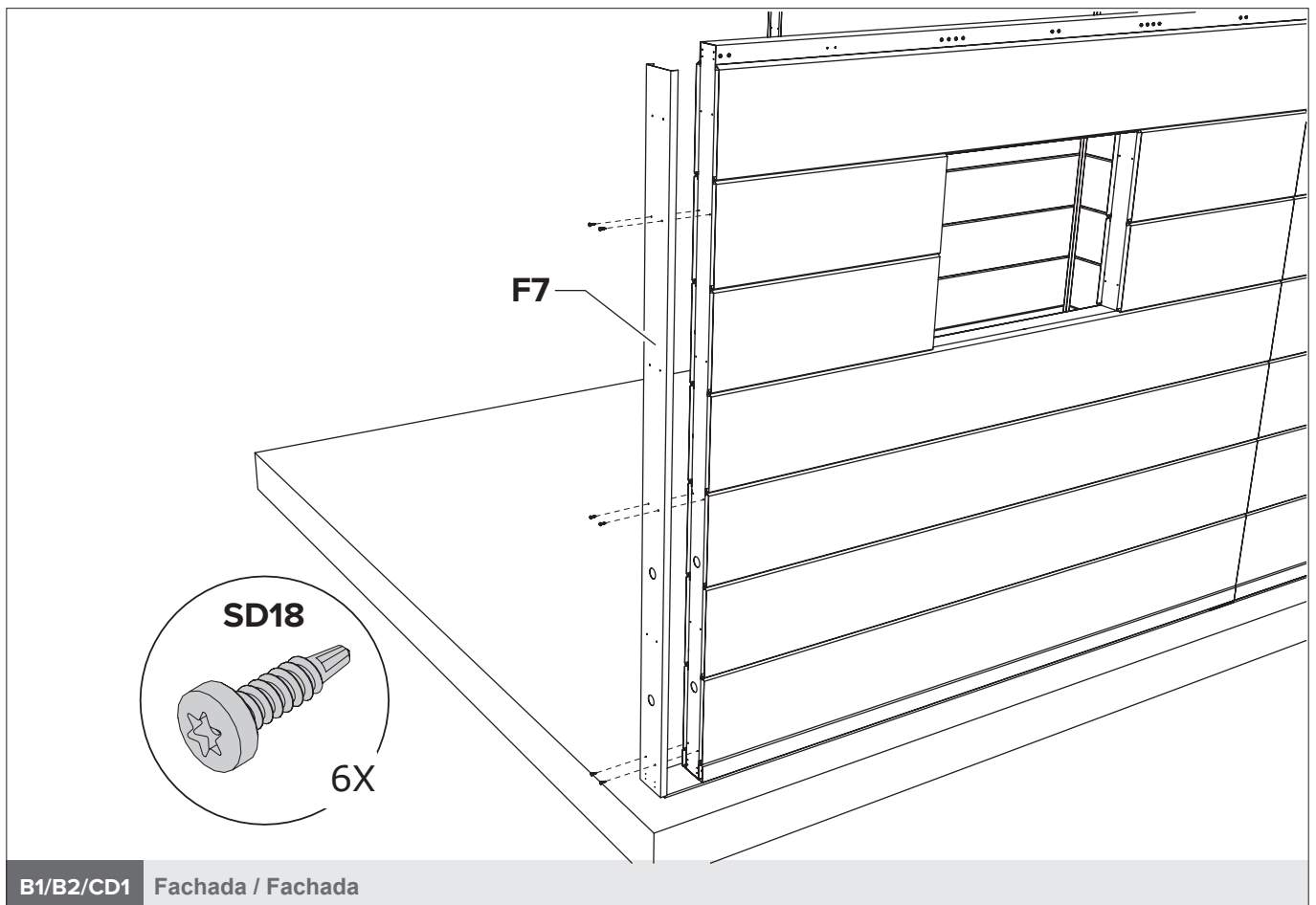
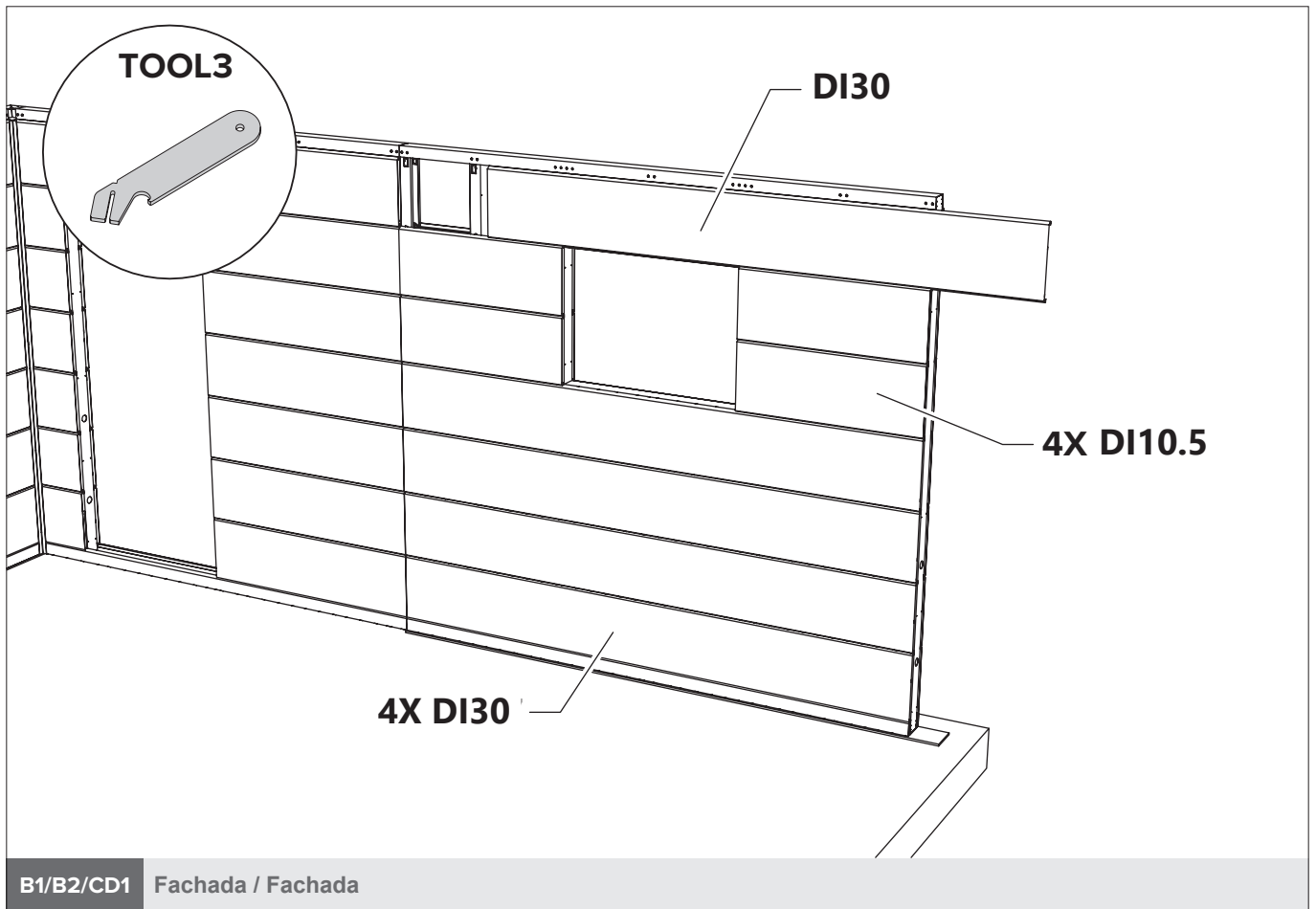

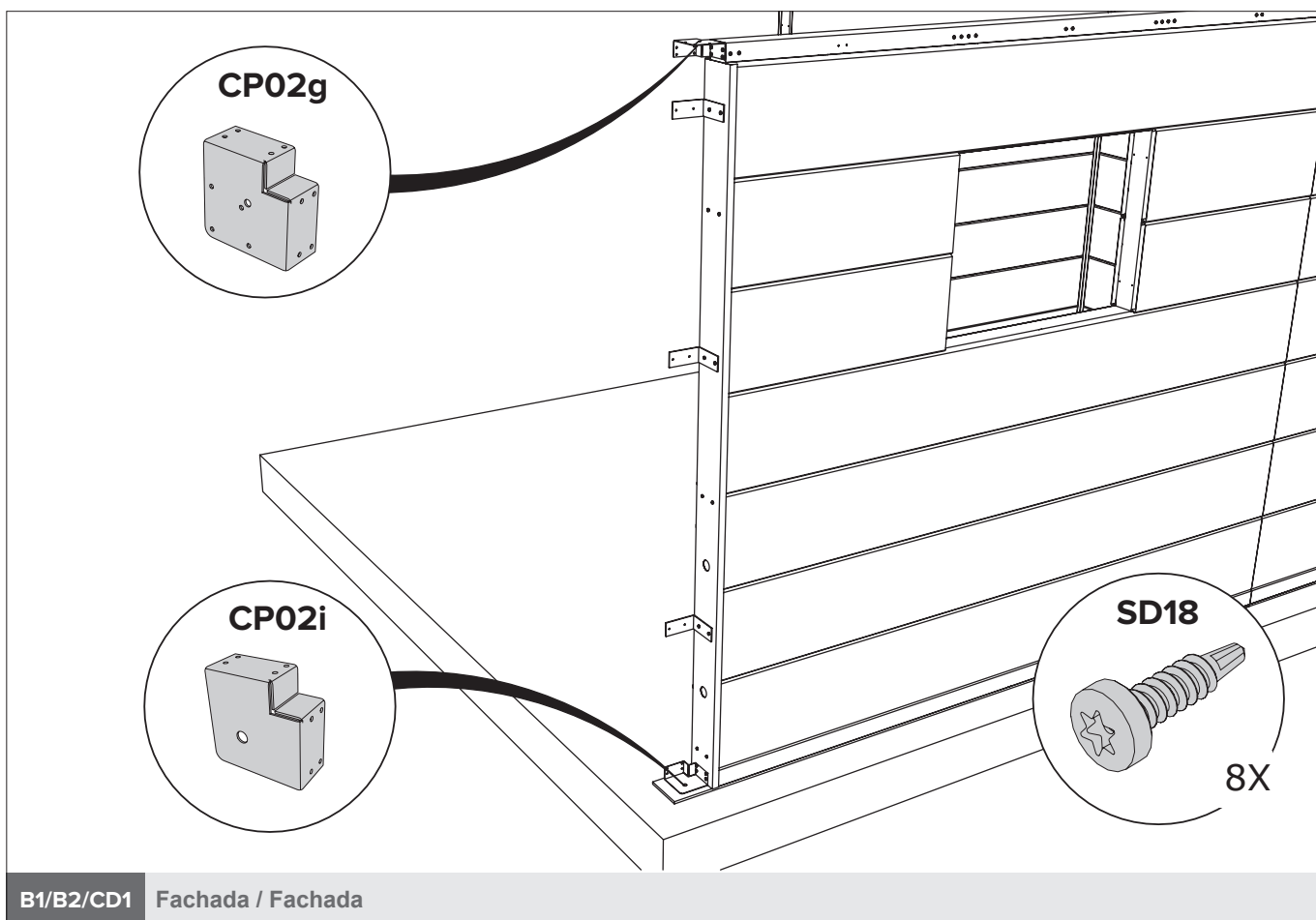
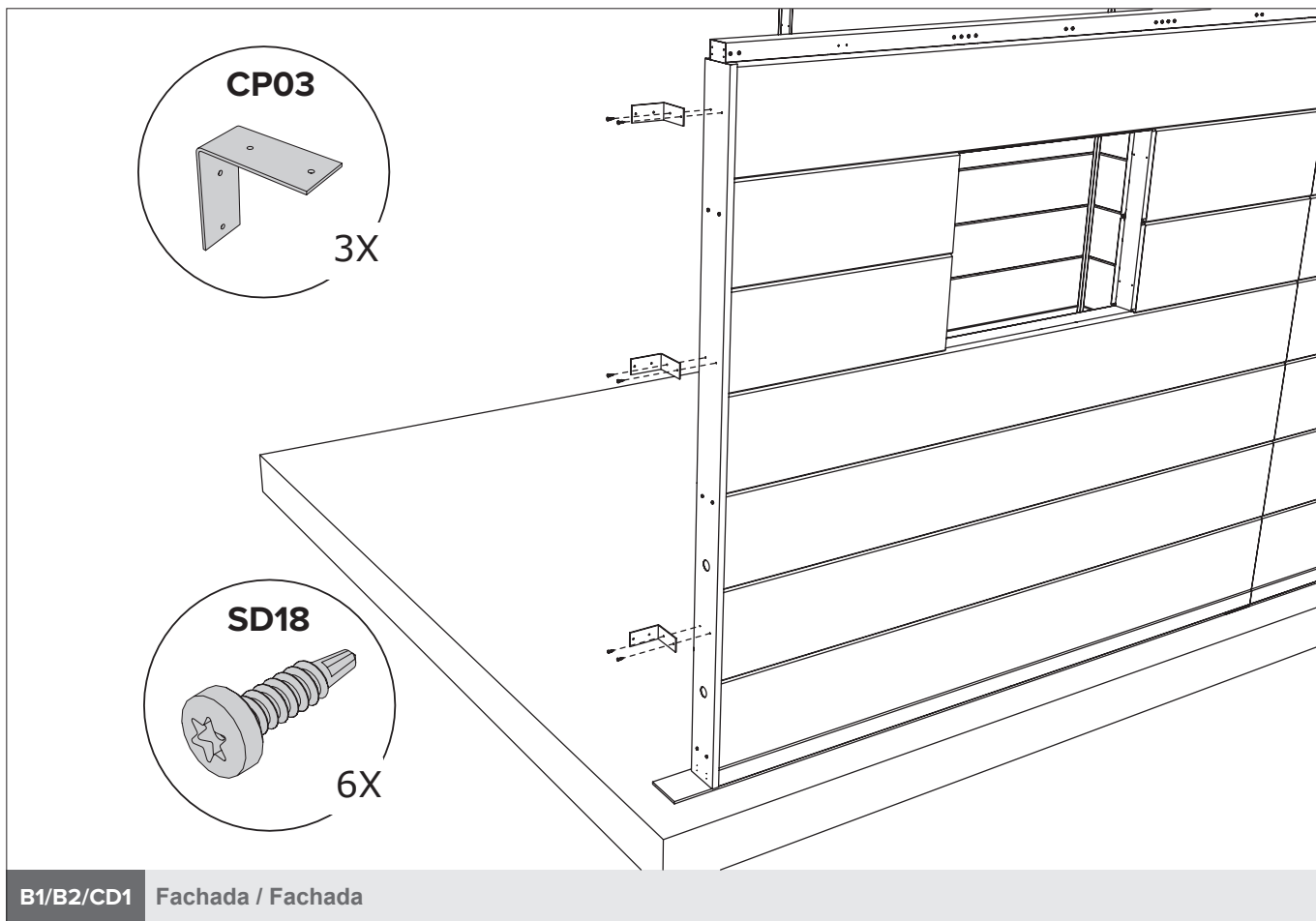

O princípio da construção da fachada, ver páginas 9 a 15 (POW).
El principio de la construcción de la fachada, ver paginas 9 a 15 (POW).

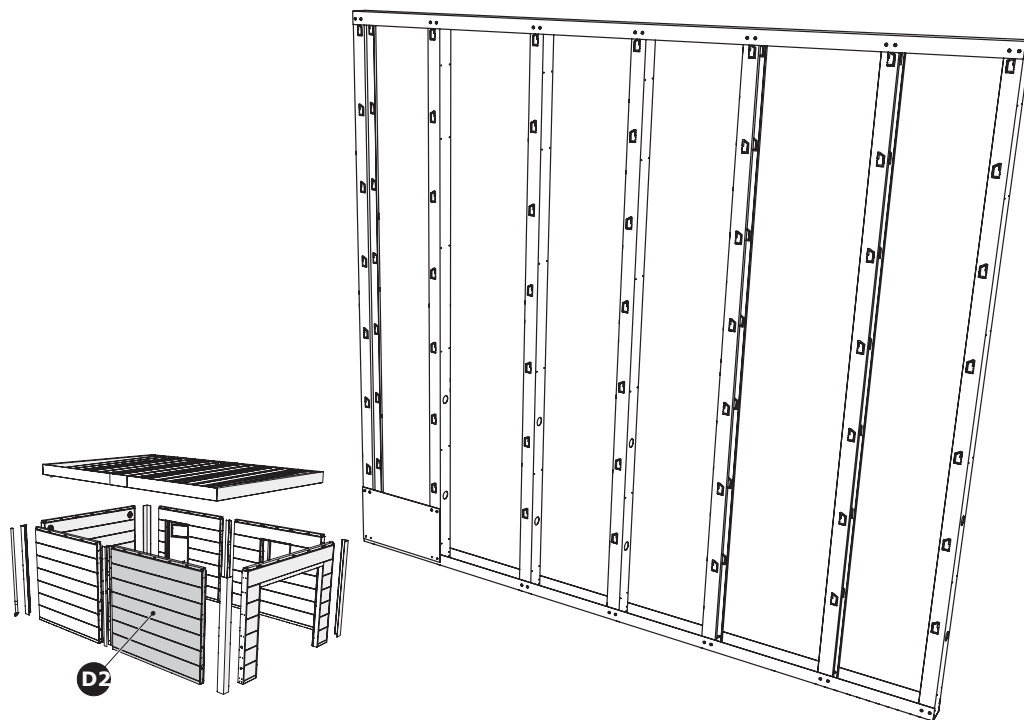

D2 Fachada / Fachada

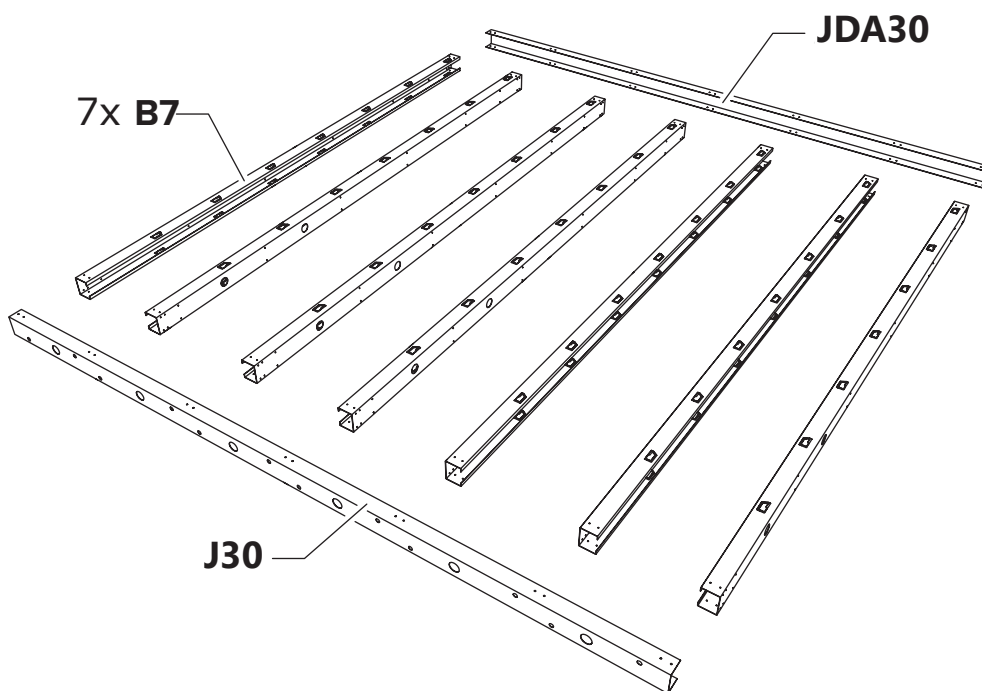

D2 Fachada / Fachada

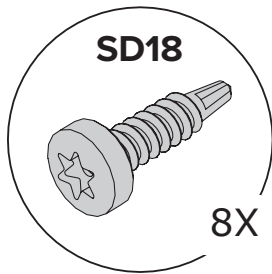
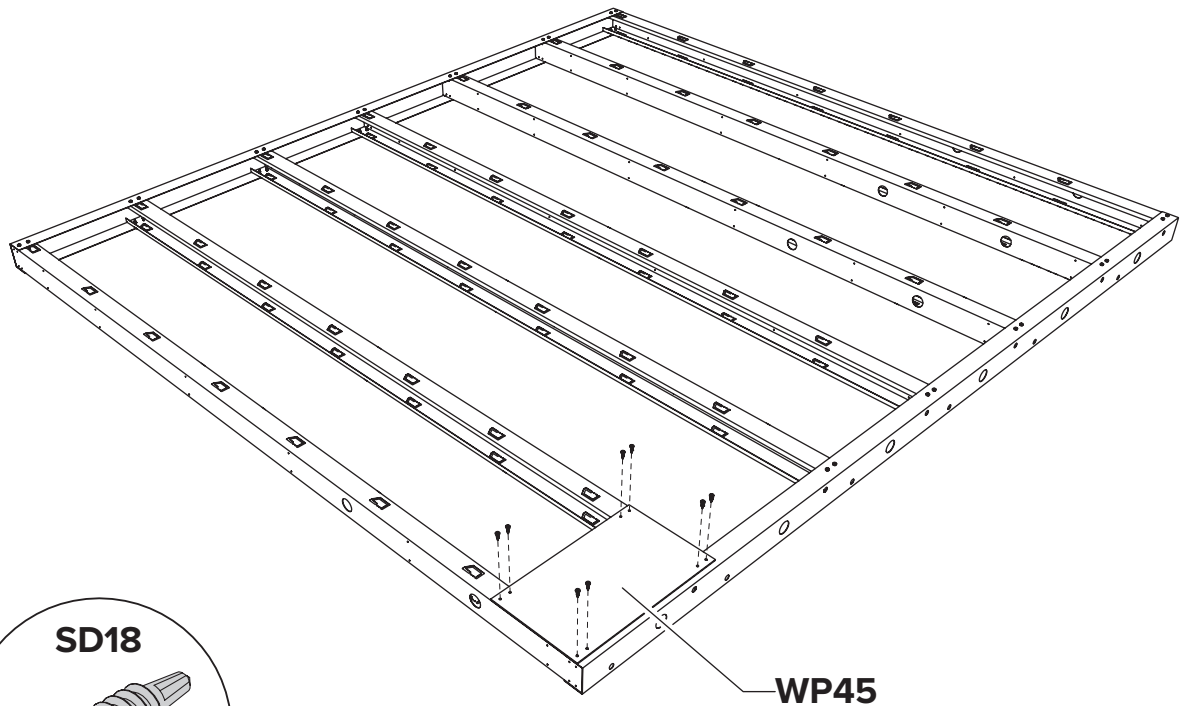

WP45

D2 Fachada / Fachada

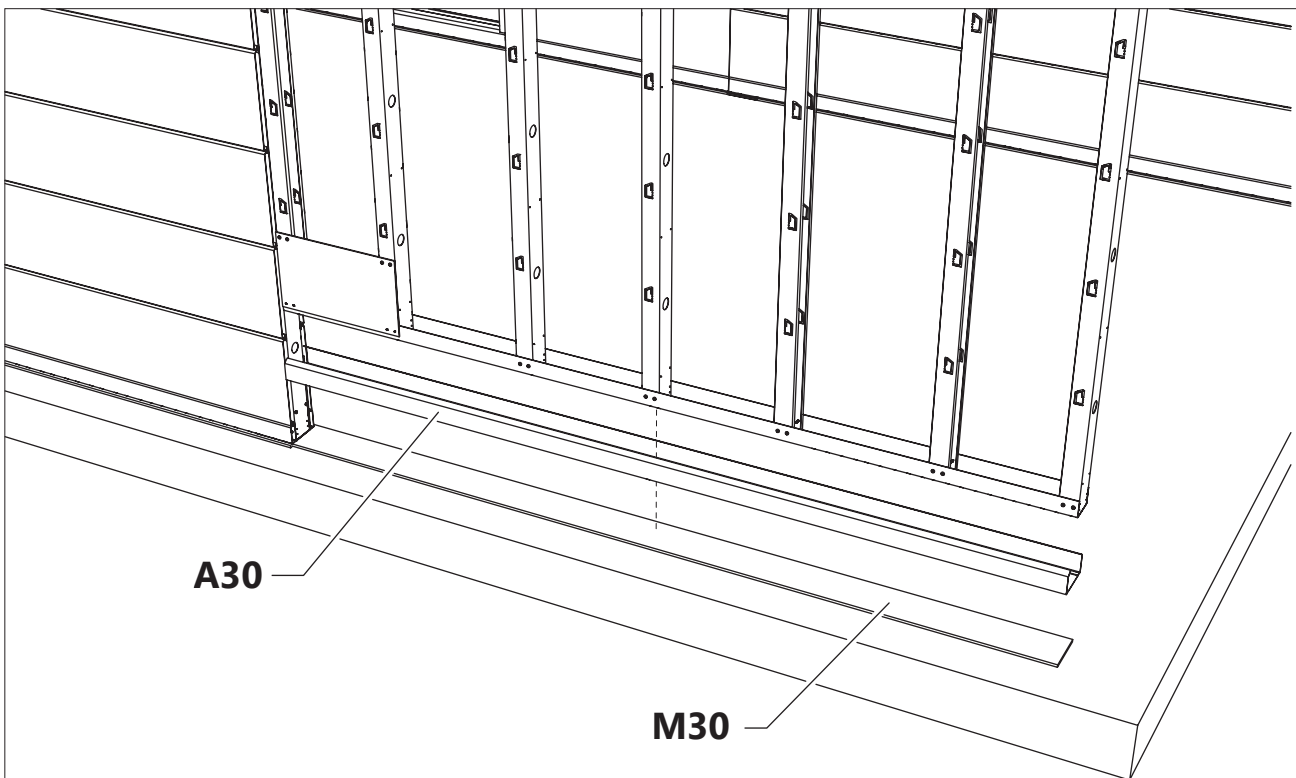

A30

M30

B1/B2/CD1/D2 Fachada / Fachada

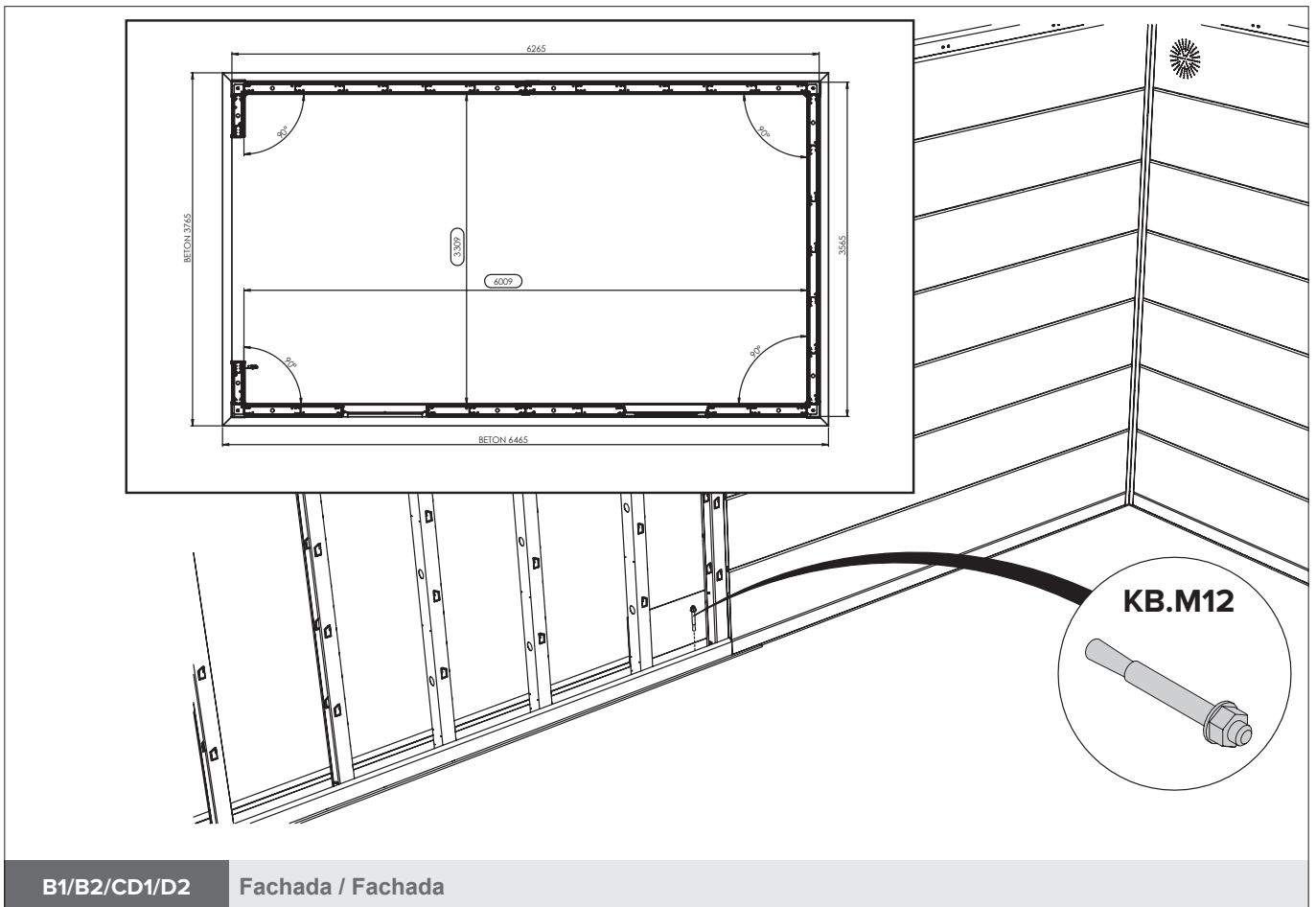
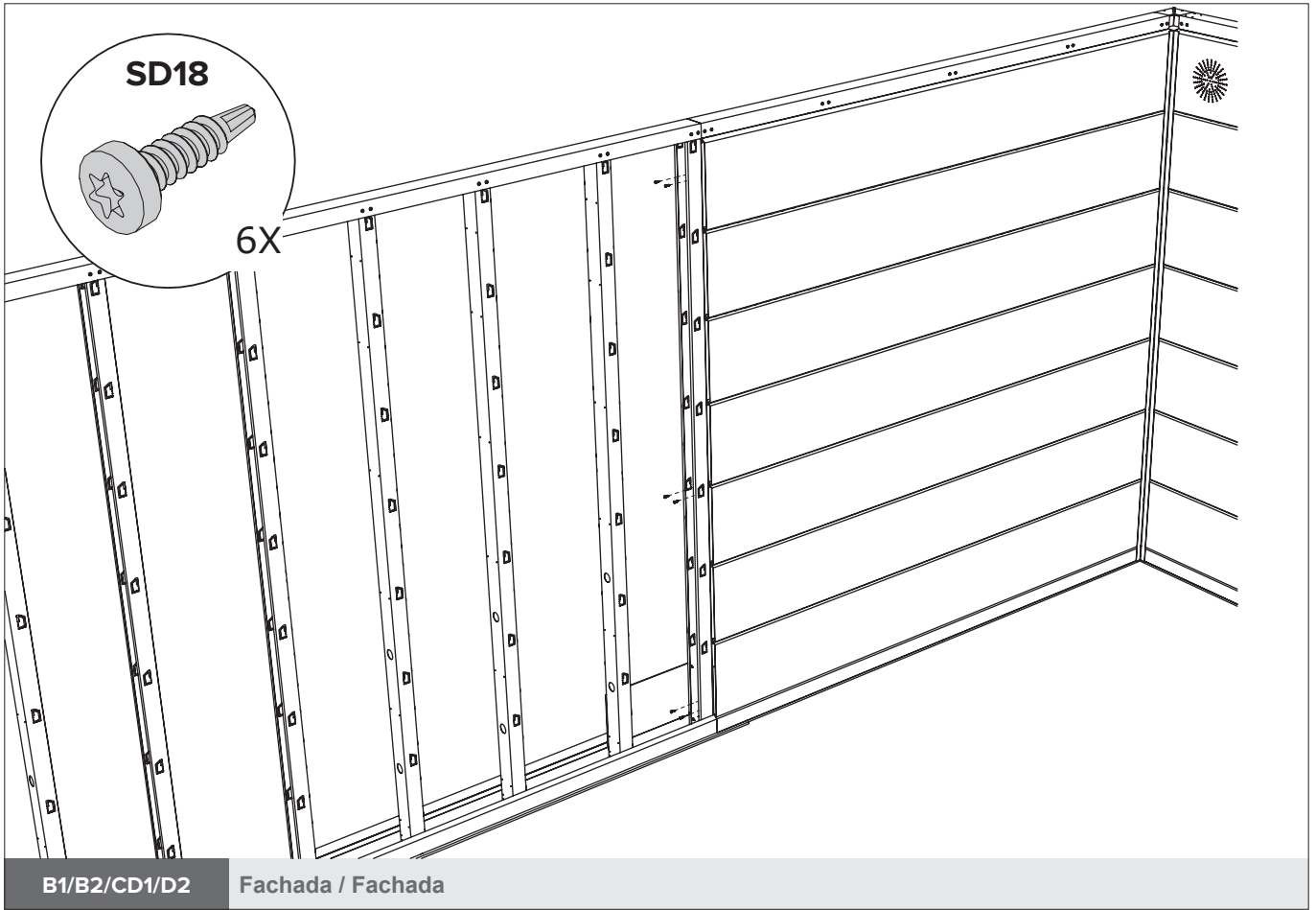

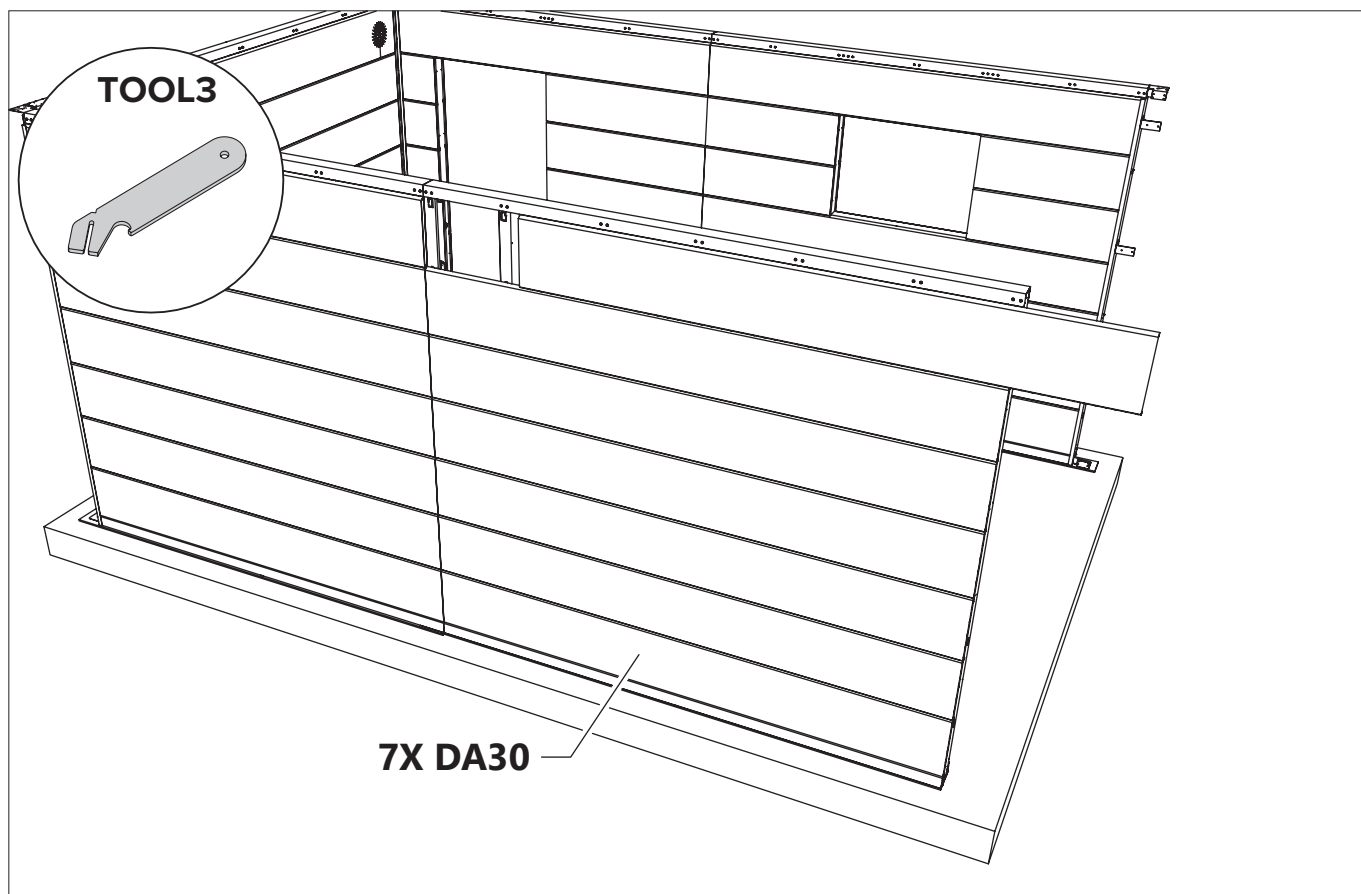

B1/B2/CD1/D2

Fachada / Fachada

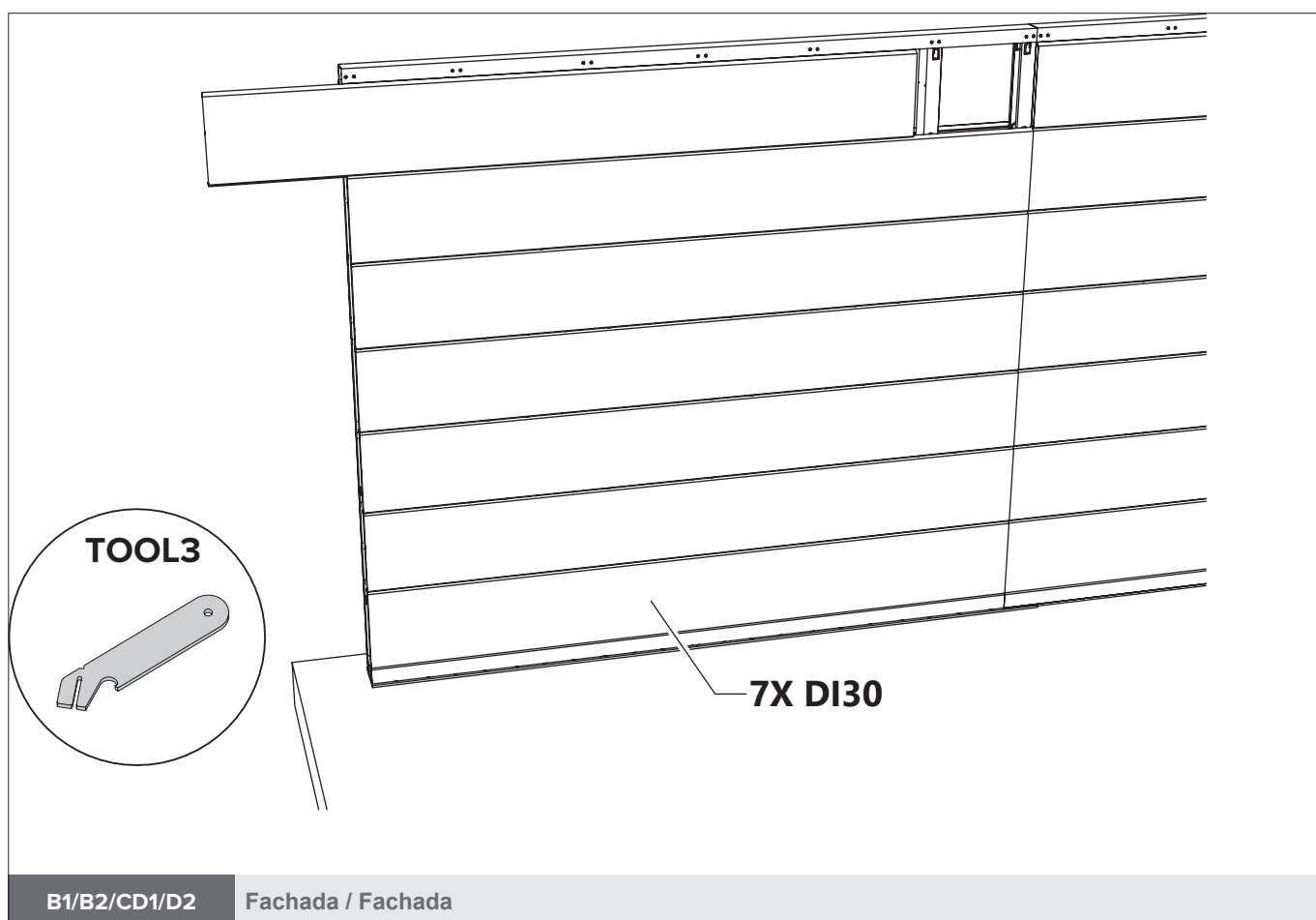

B1/B2/CD1/D2

Fachada / Fachada

GARAGEM / GARAJE NH2

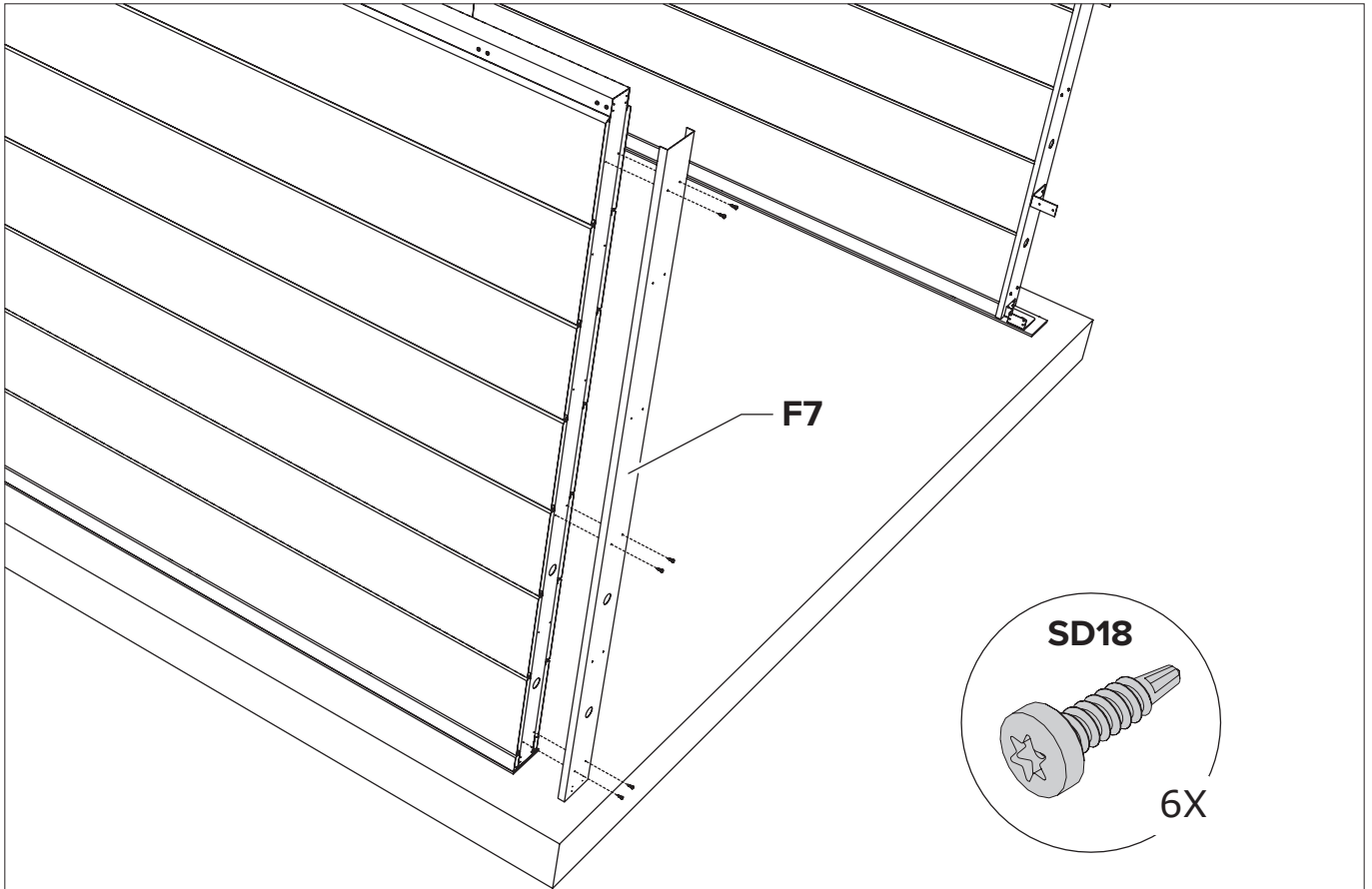

B1/B2/CD1/D2

Fachada / Fachada

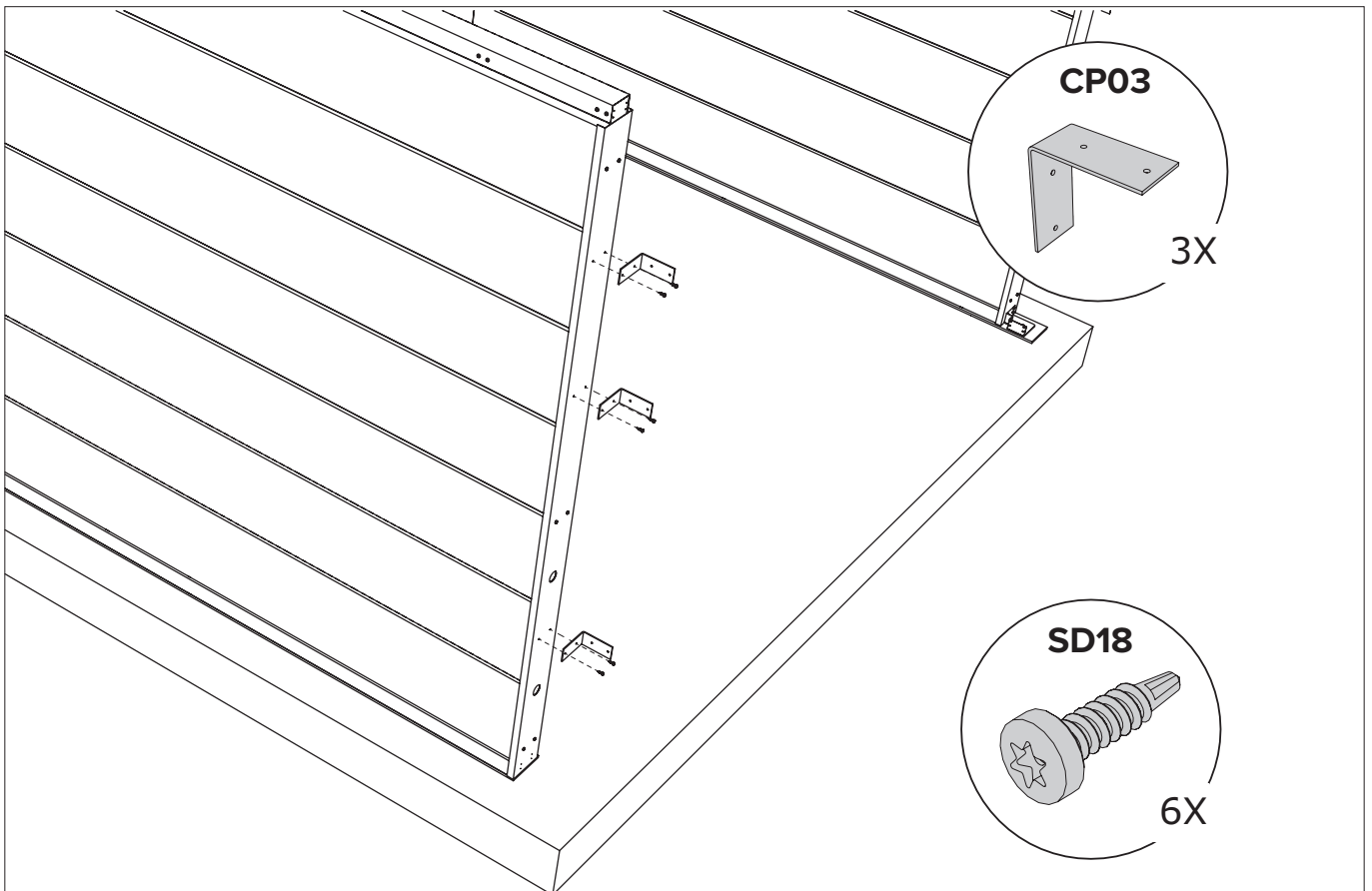

B1/B2/CD1/D2

Fachada / Fachada

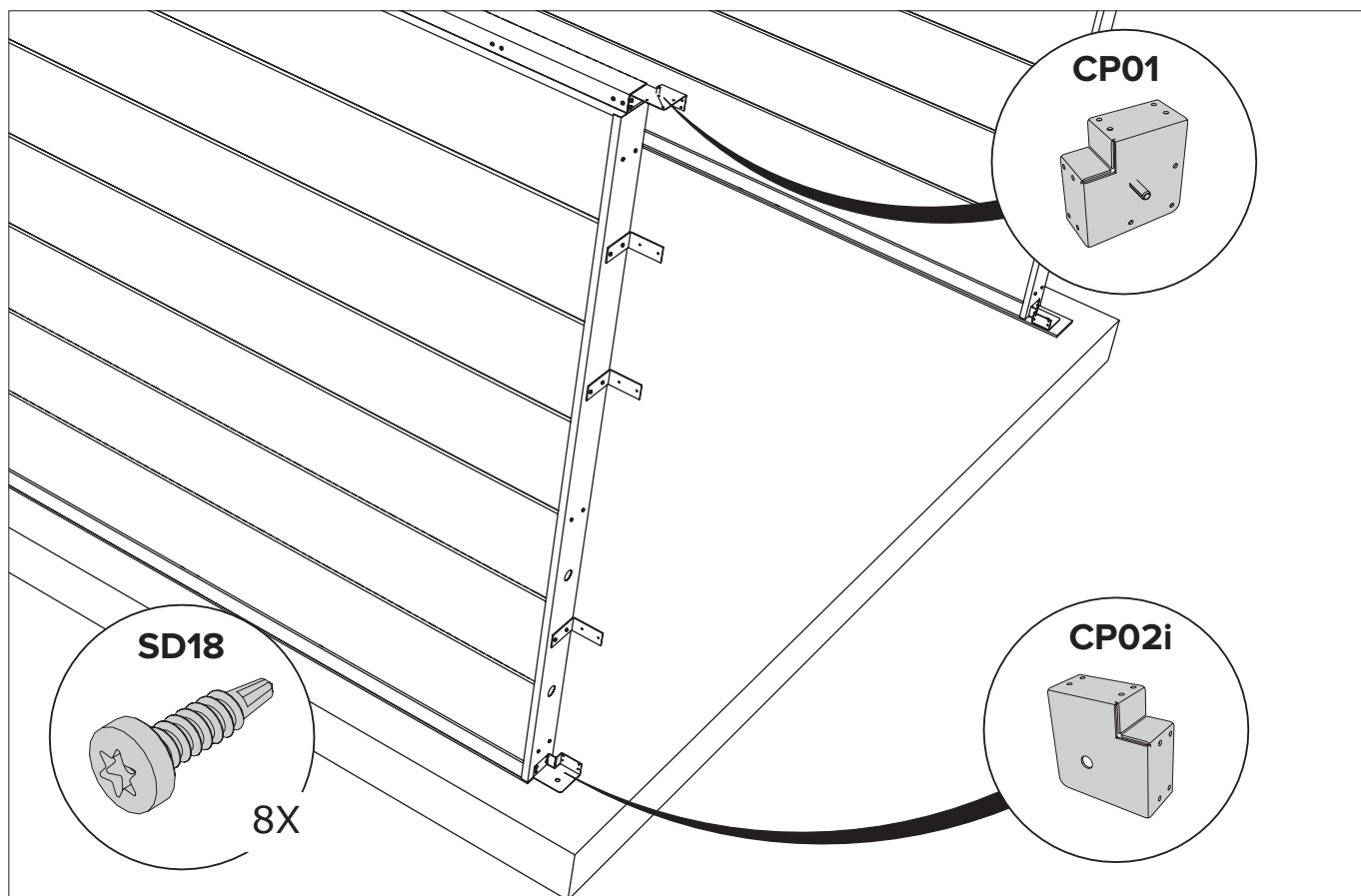

B1/B2/CD1/D2 Fachada / Fachada

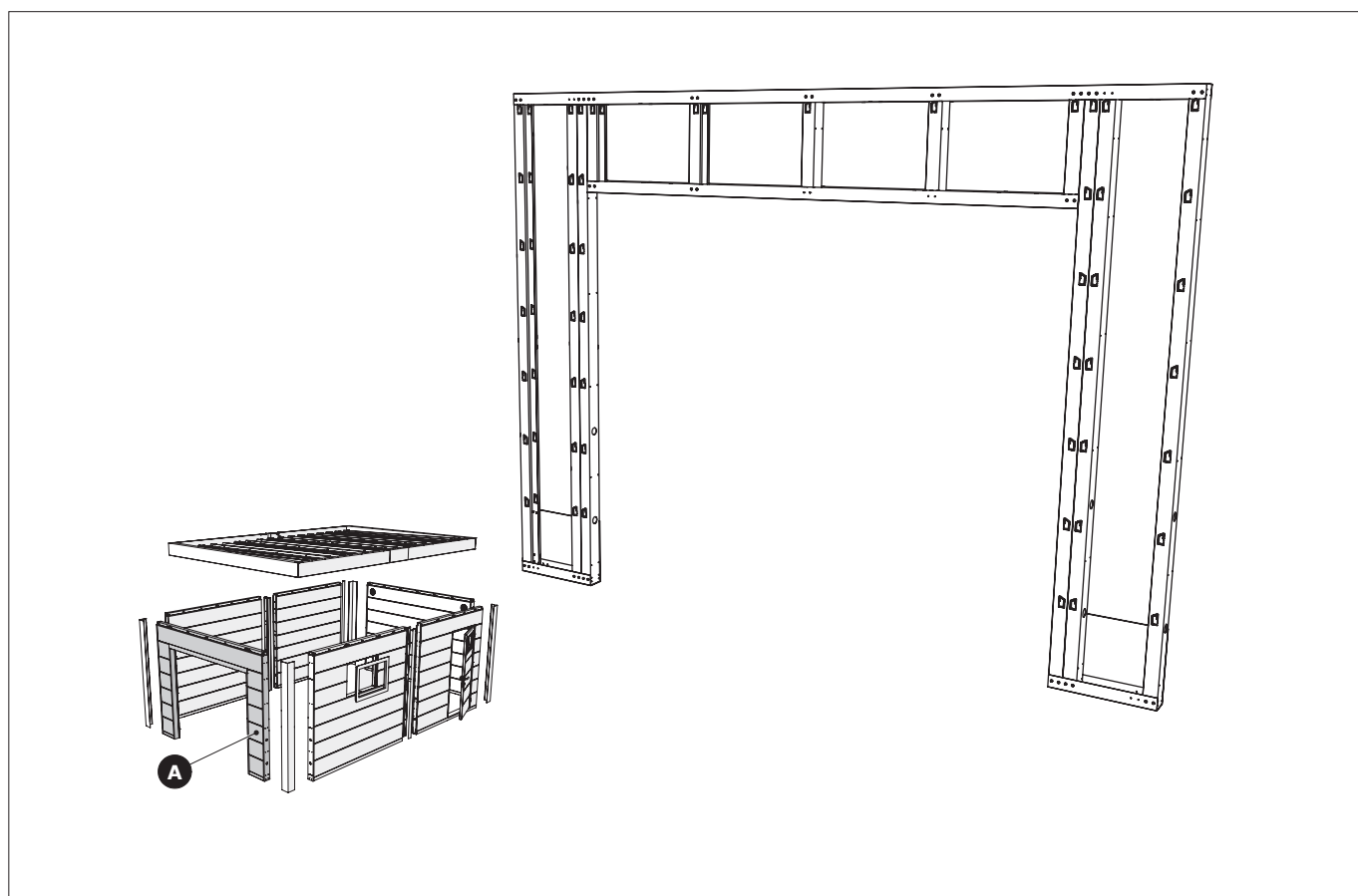

A Fachada / Fachada

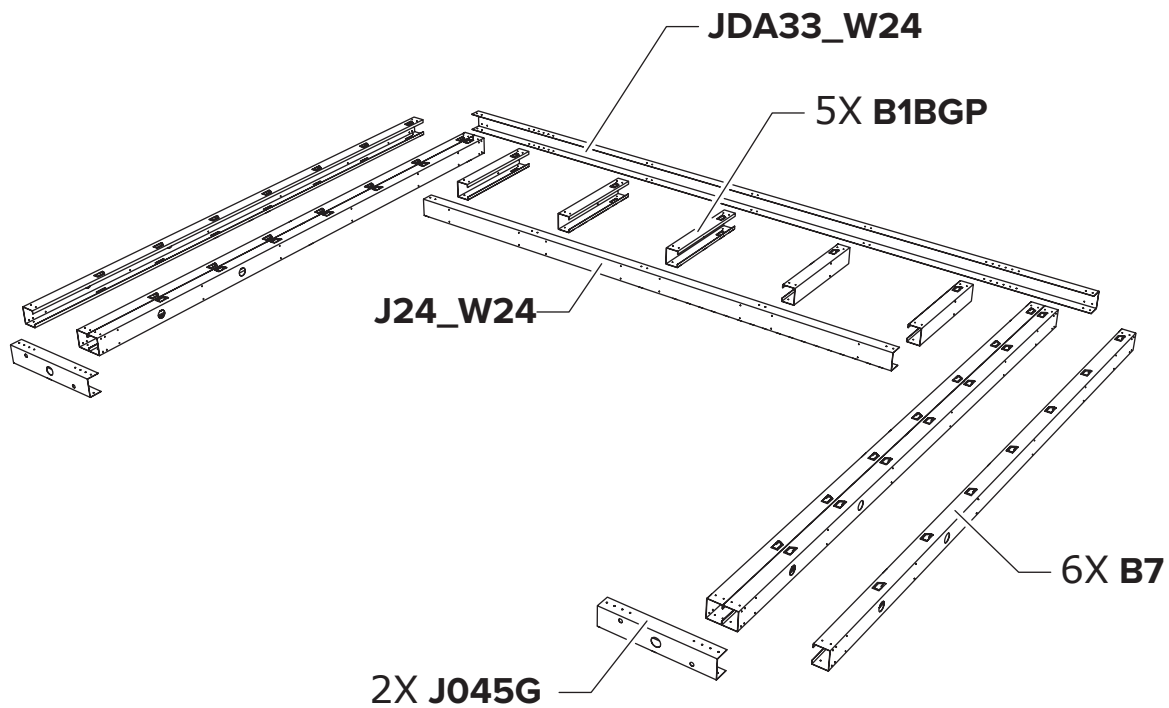

A Fachada / Fachada

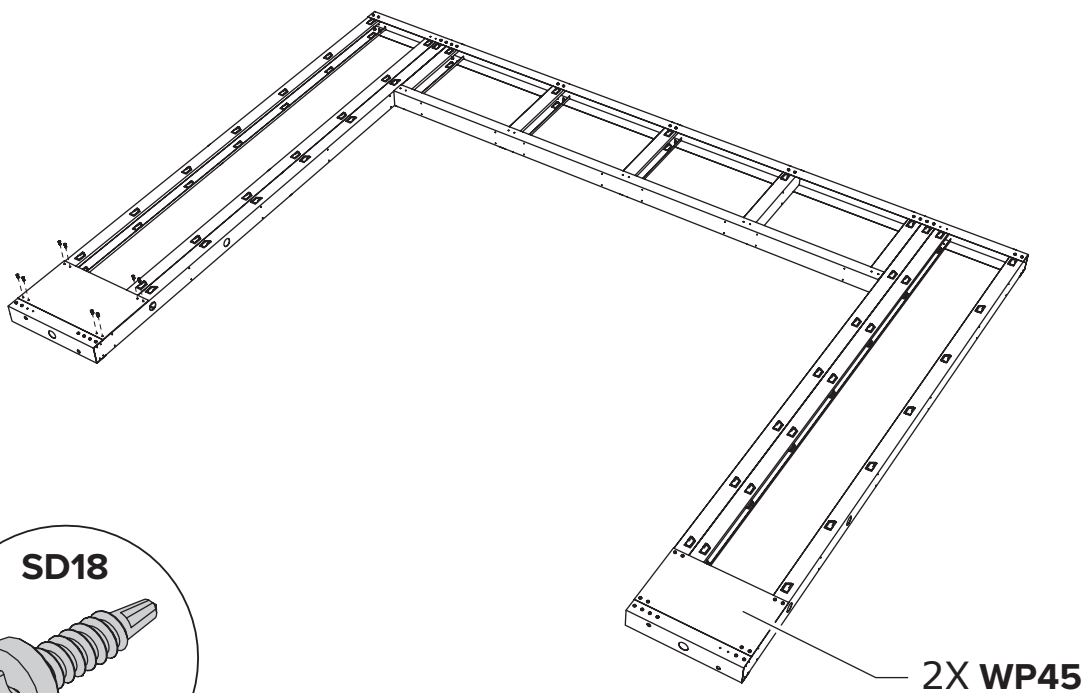

A Fachada / Fachada

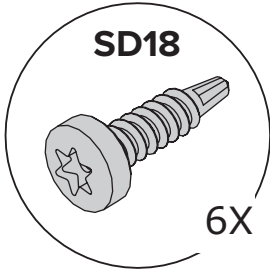
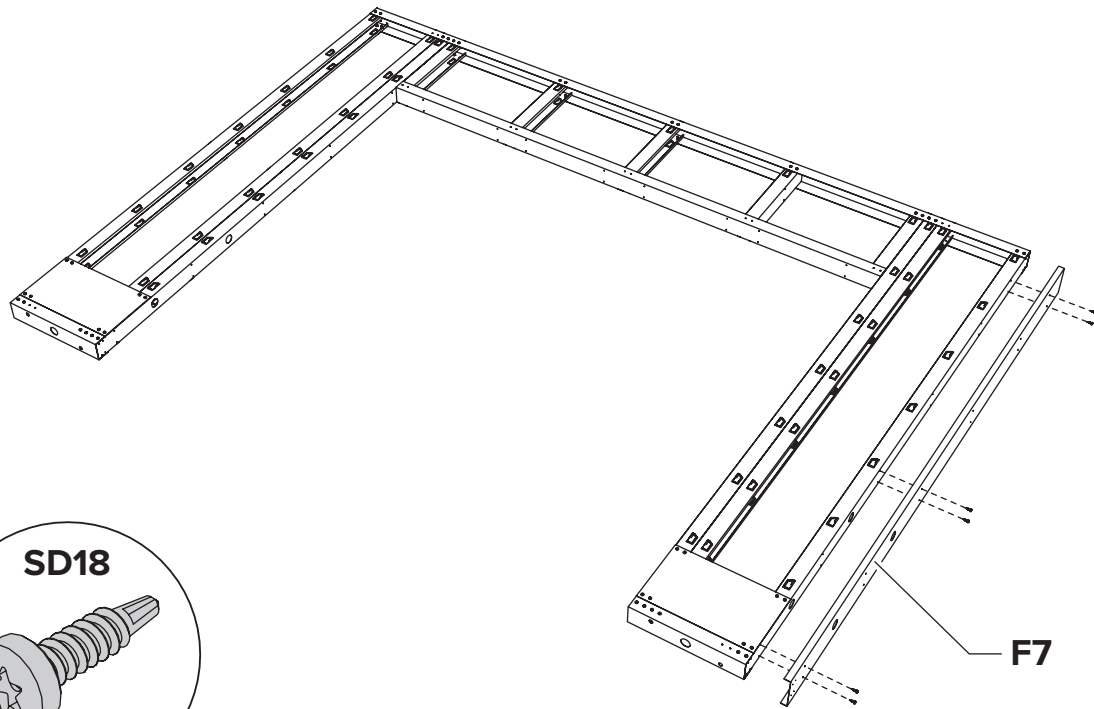

F7

A Fachada / Fachada

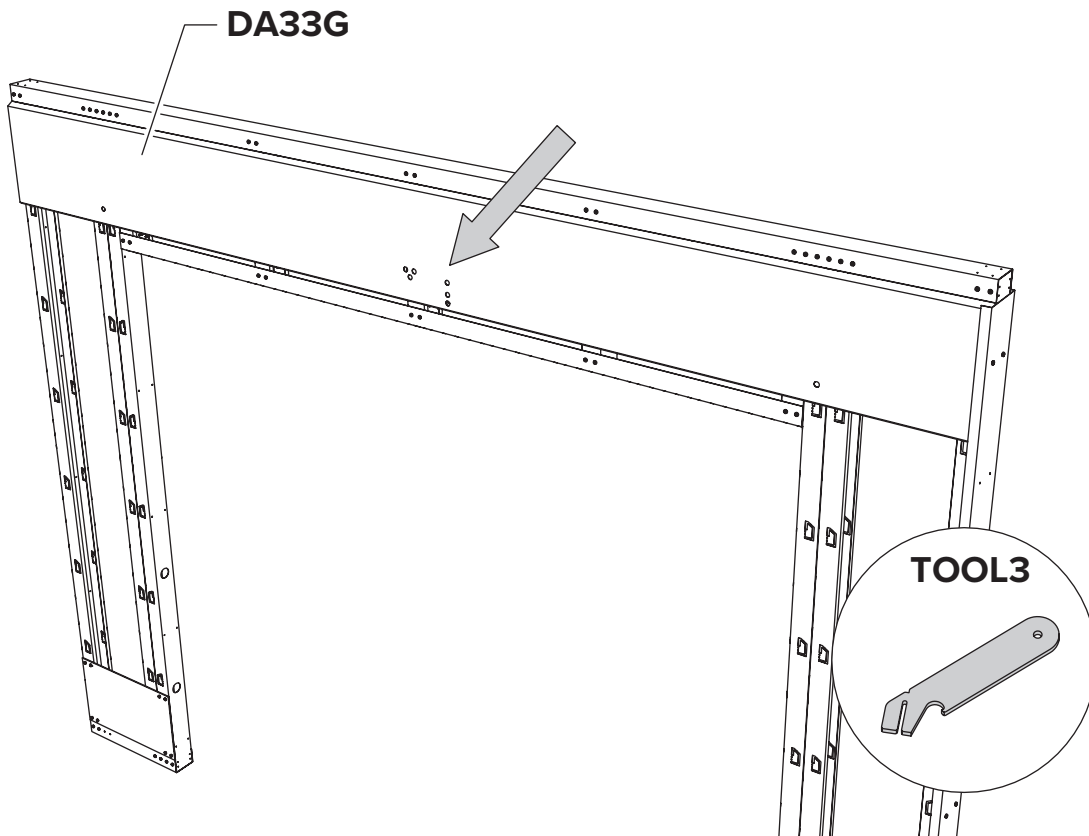

DA33G

TOOL3

A Fachada / Fachada

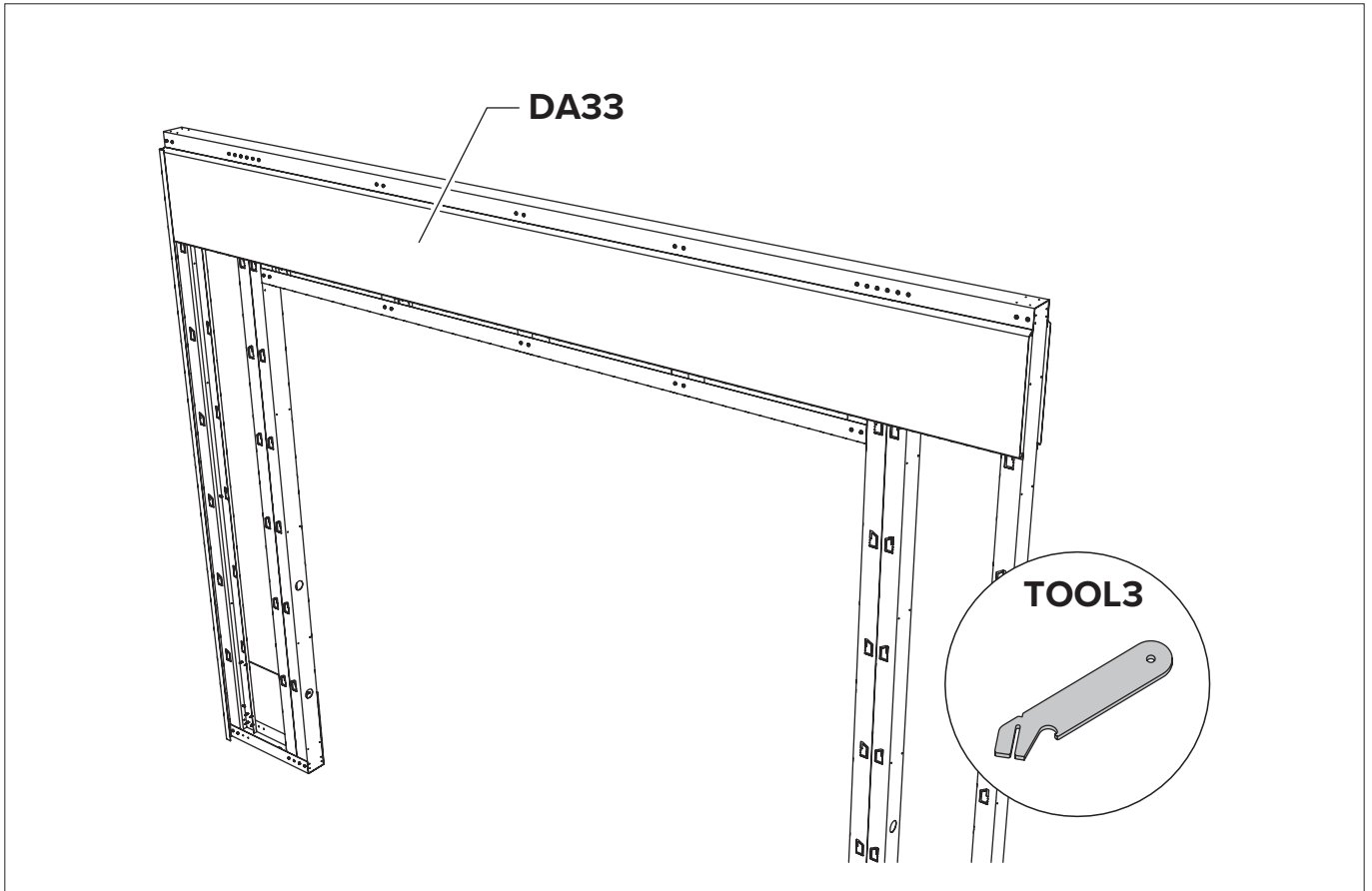

A Fachada / Fachada

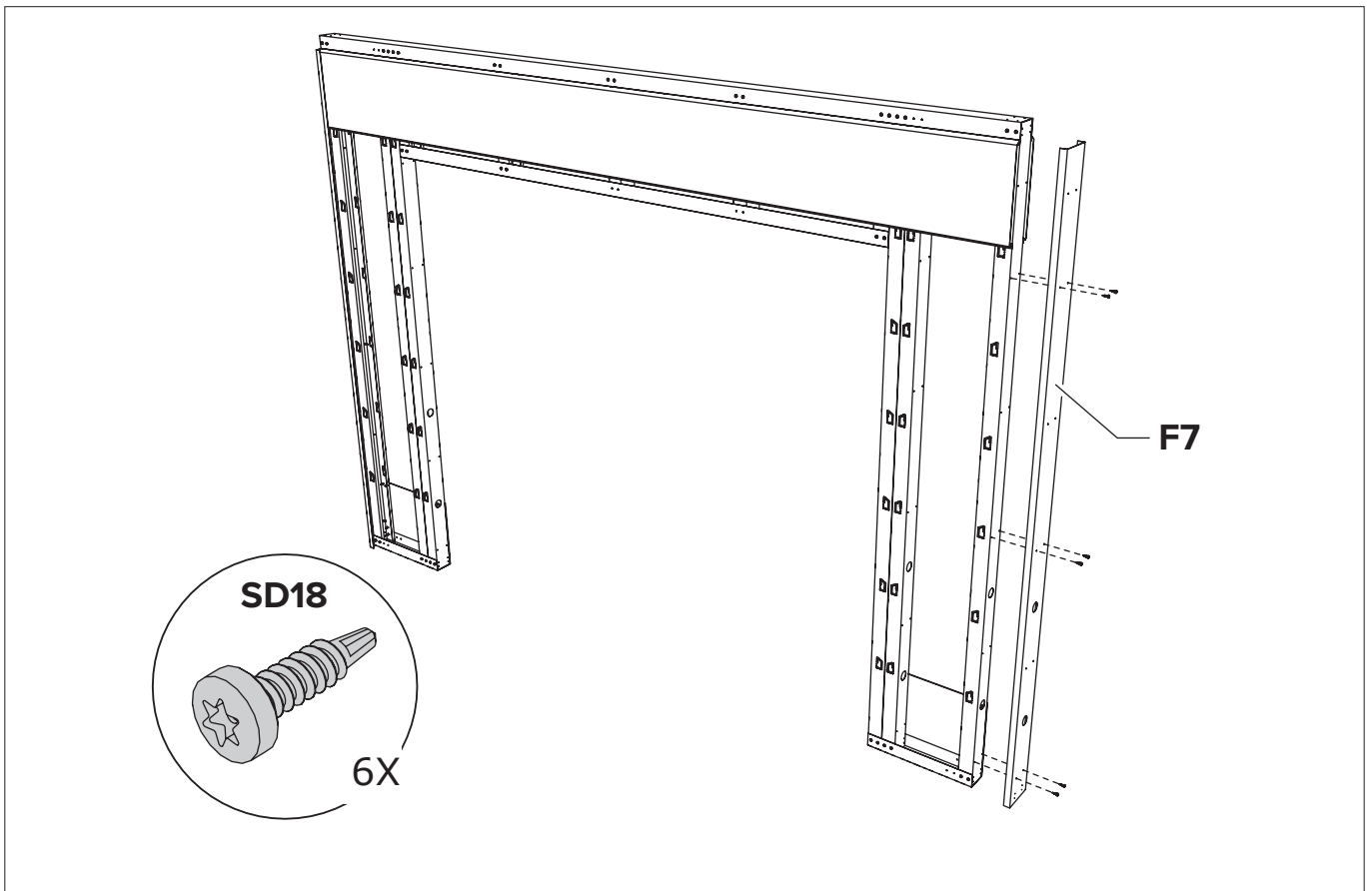

A Fachada / Fachada

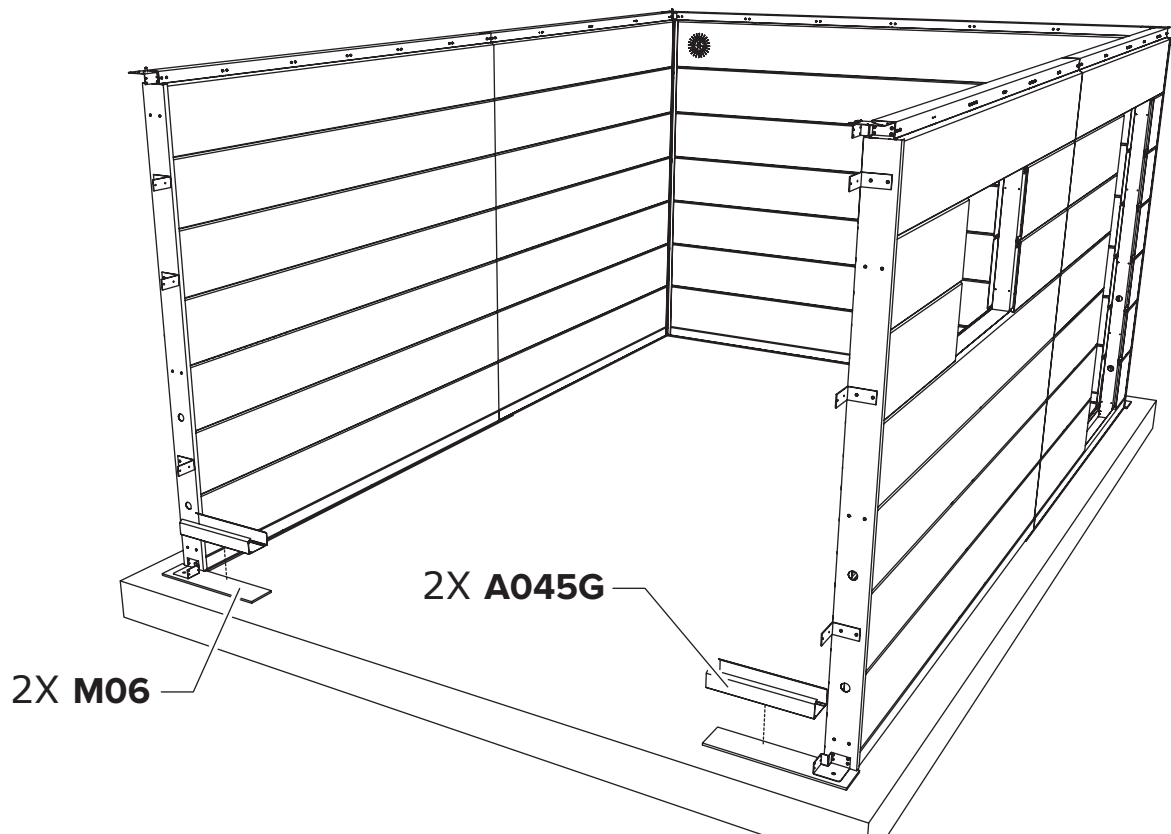

A/B/C/D Fachada / Fachada

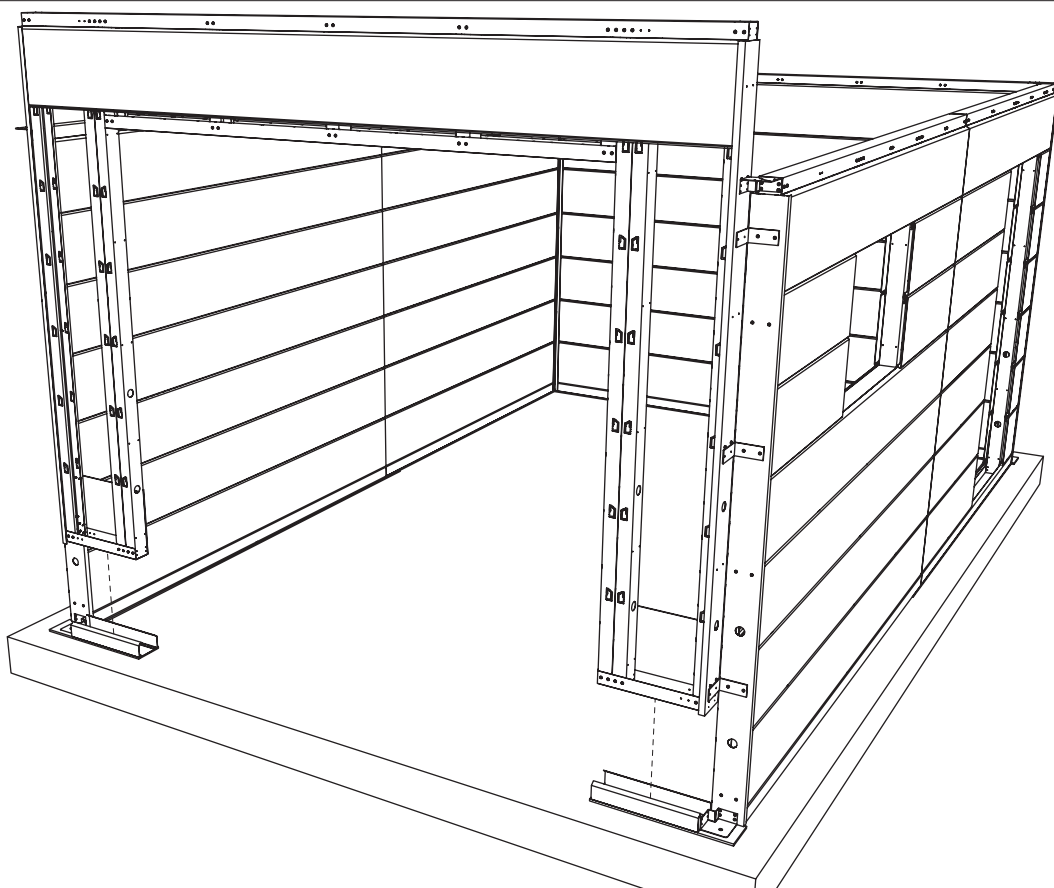

A/B/C/D Fachada / Fachada

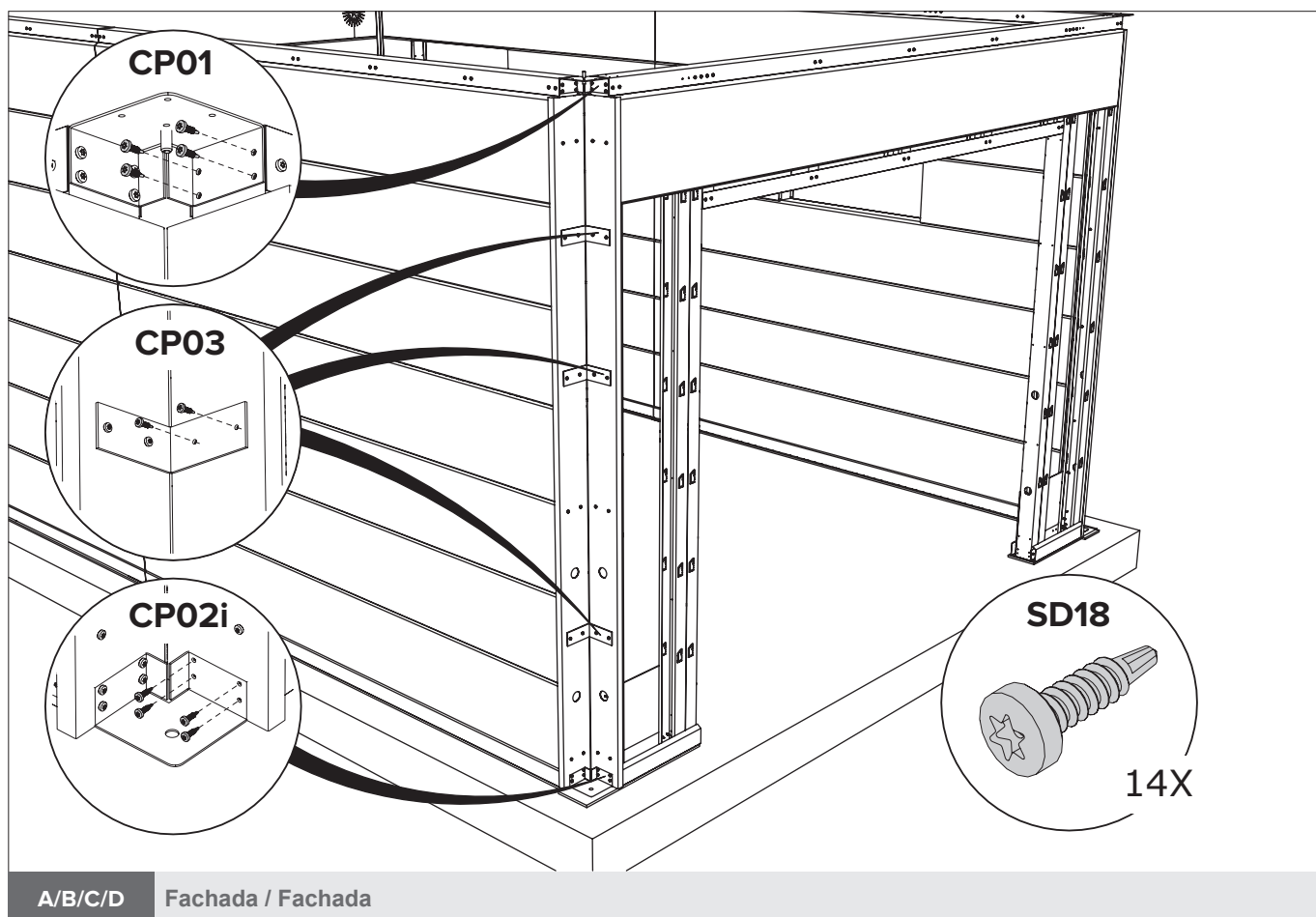
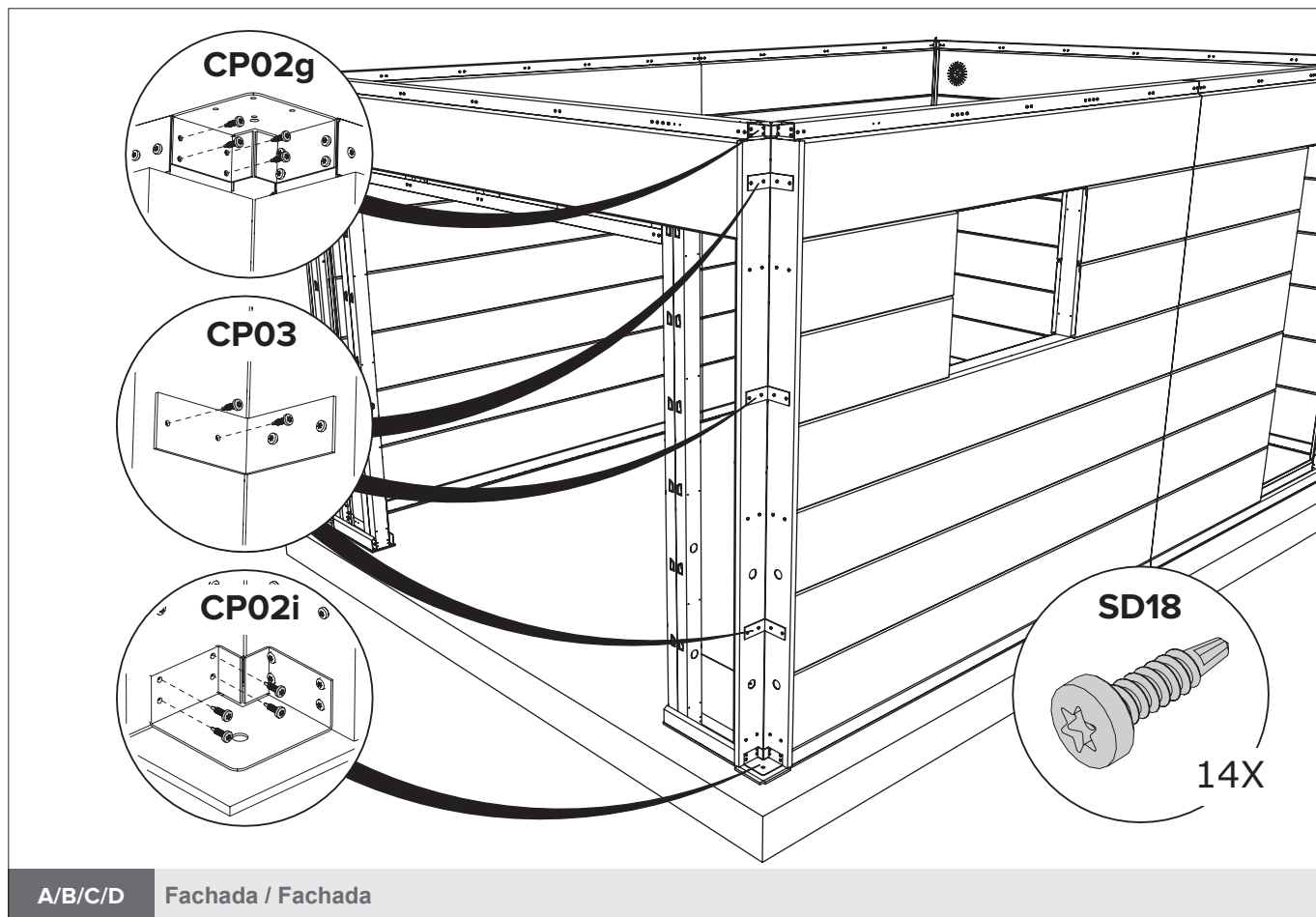

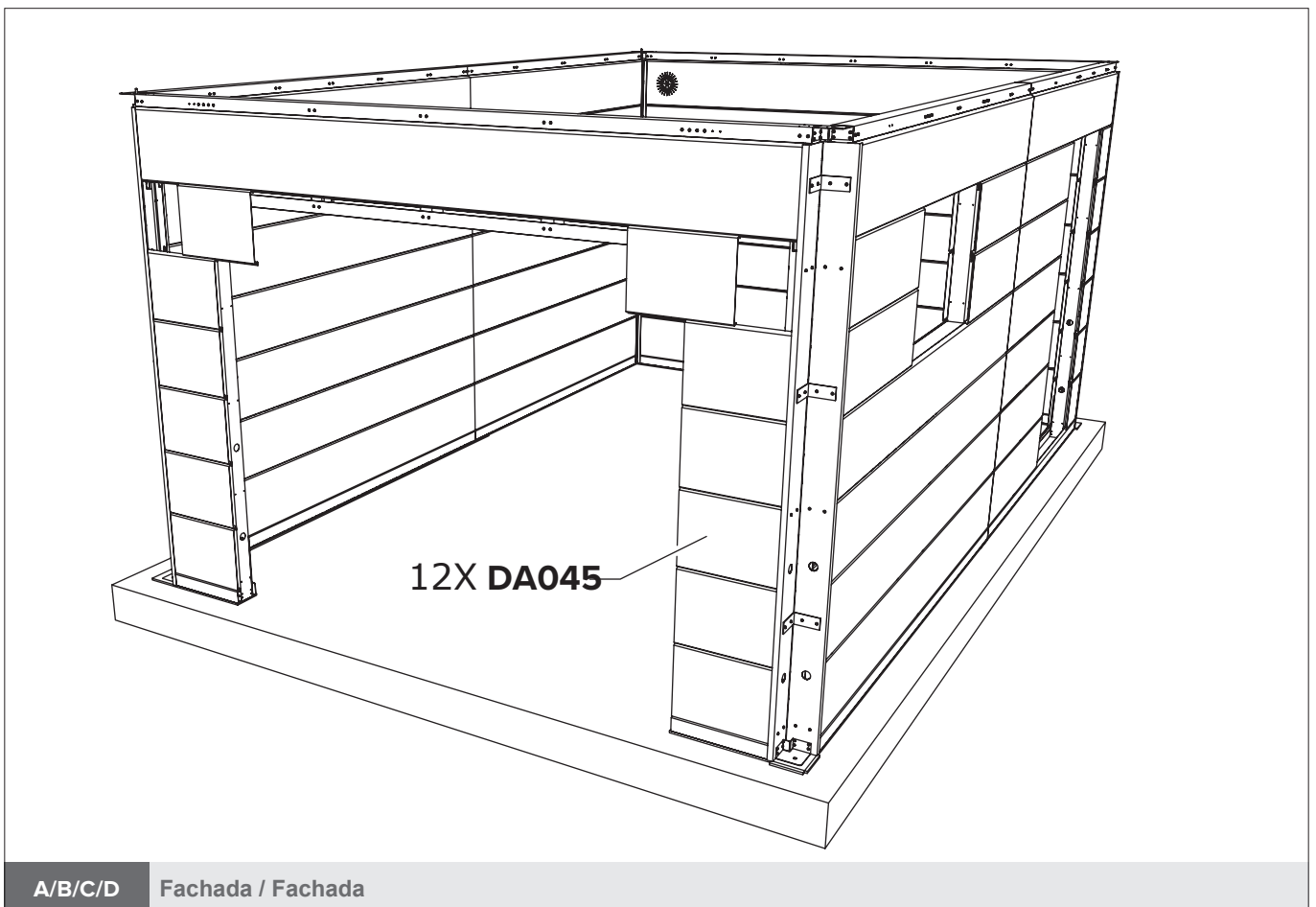
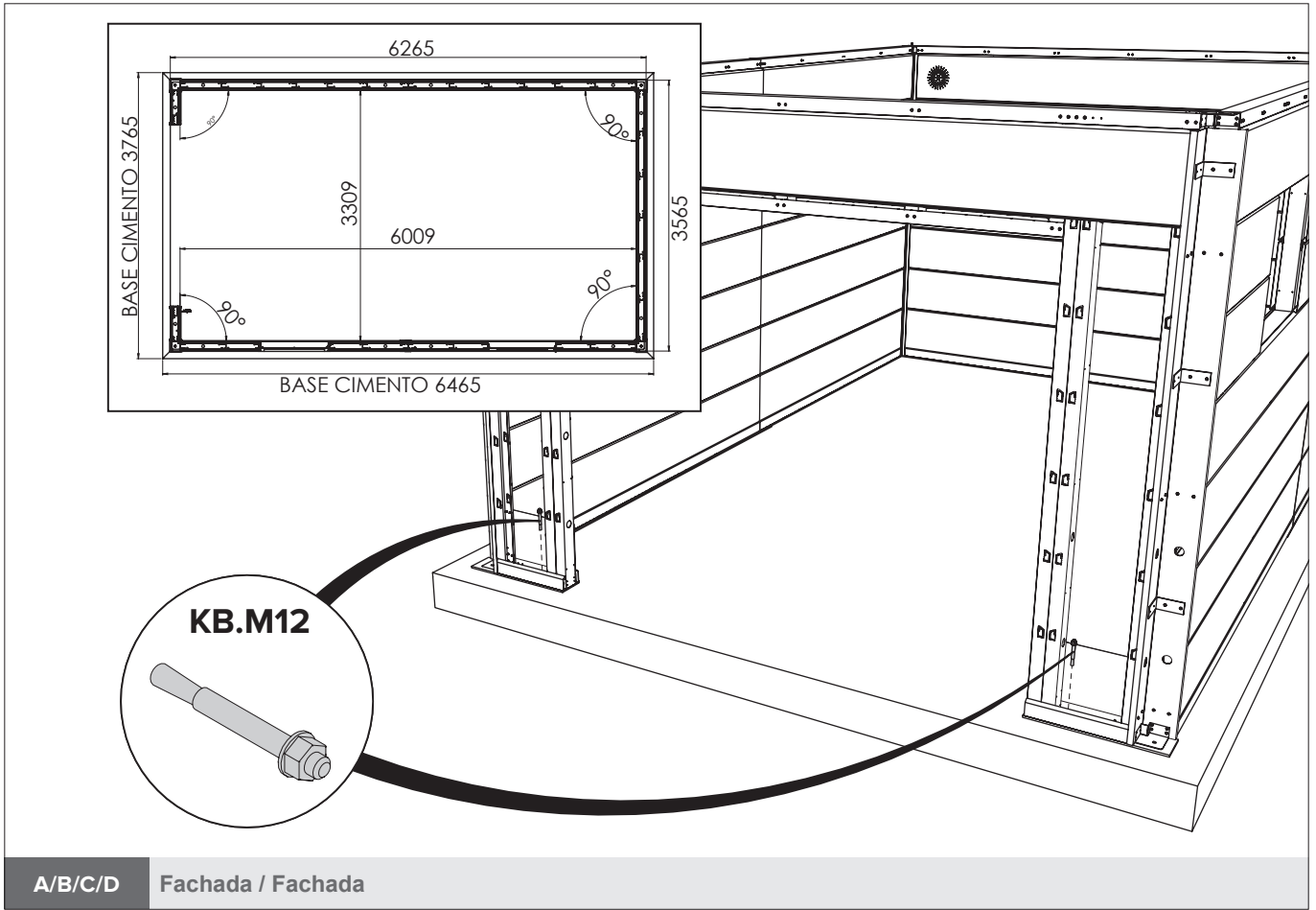

GARAGEM / GARAJE NH2

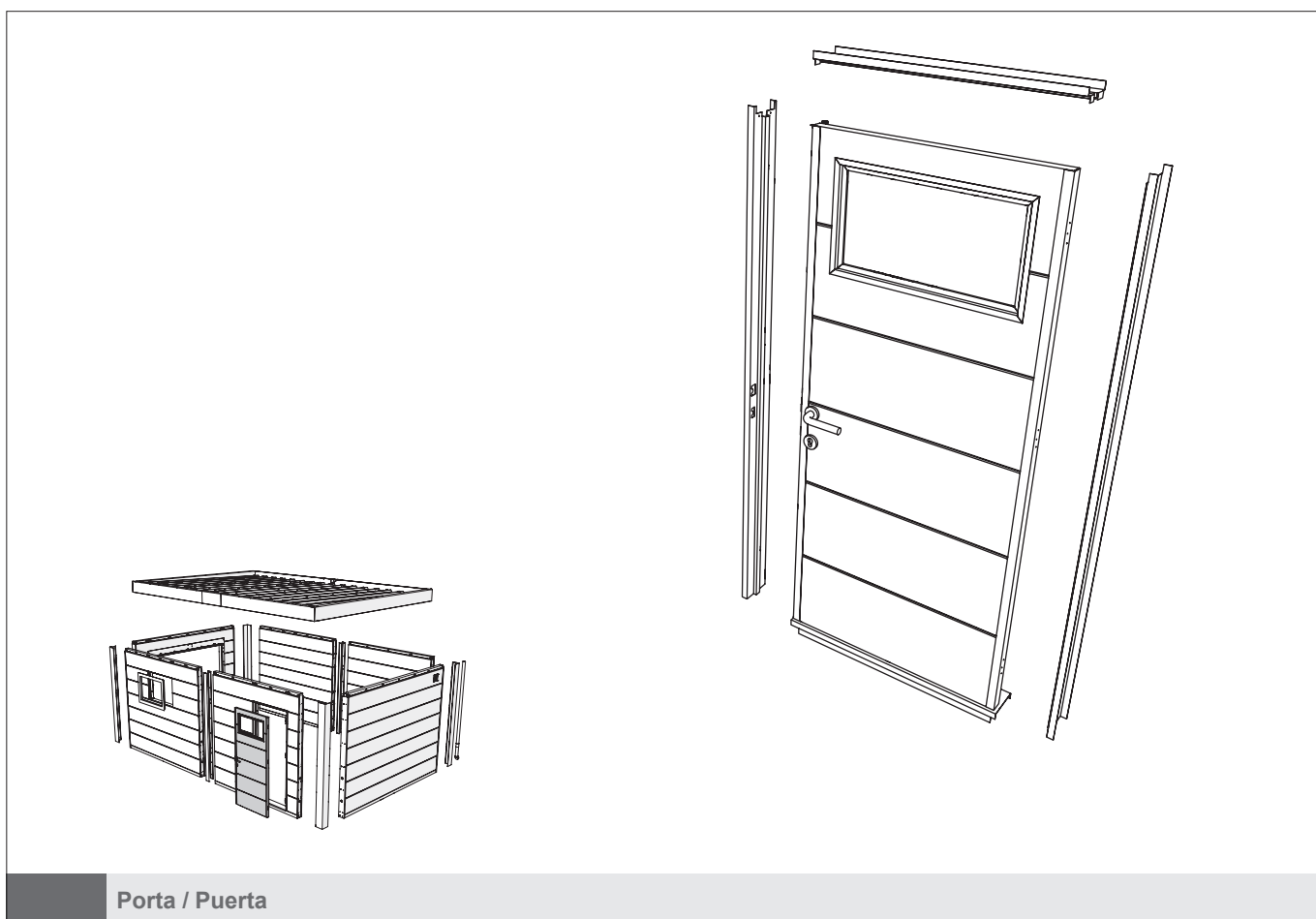
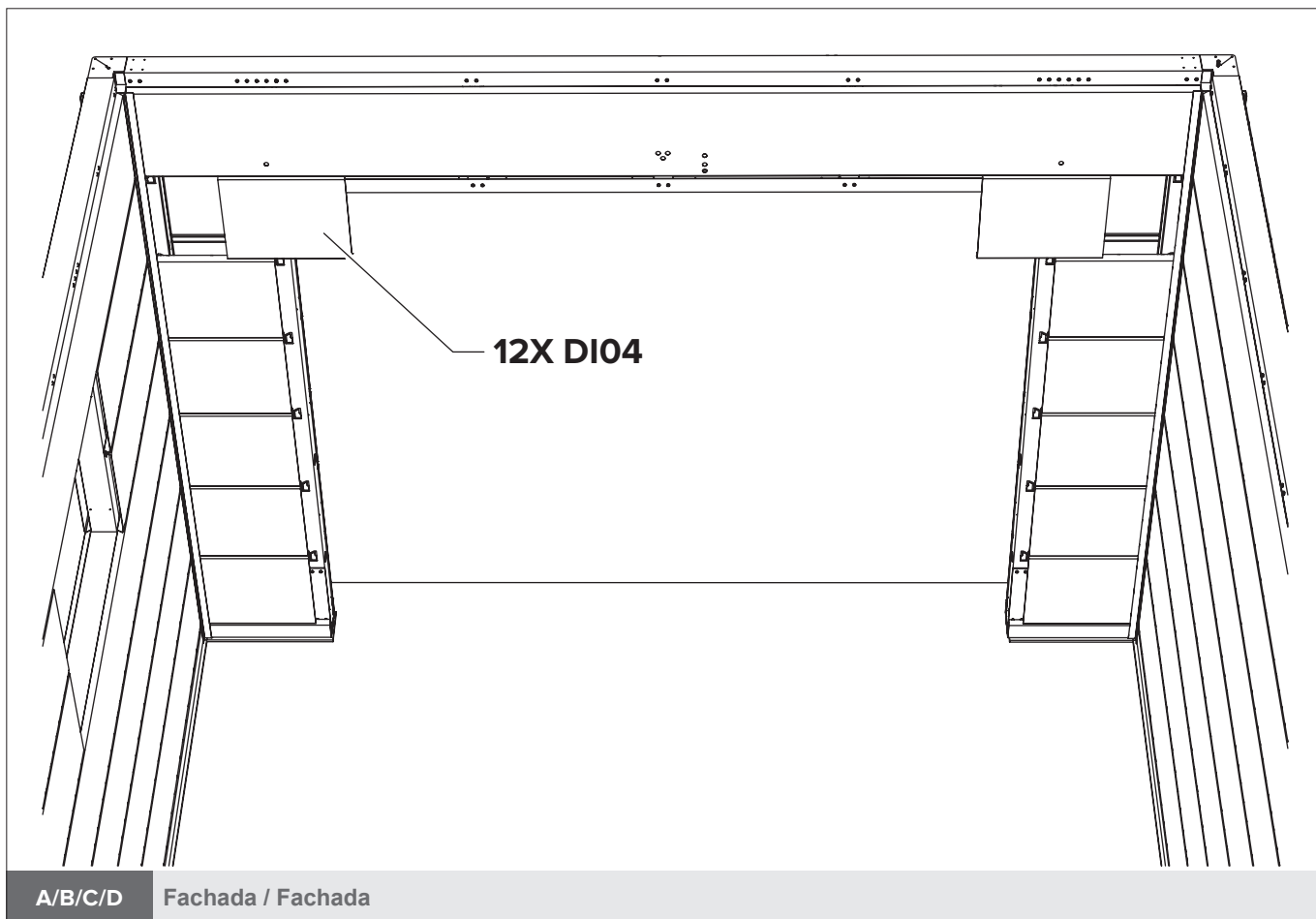

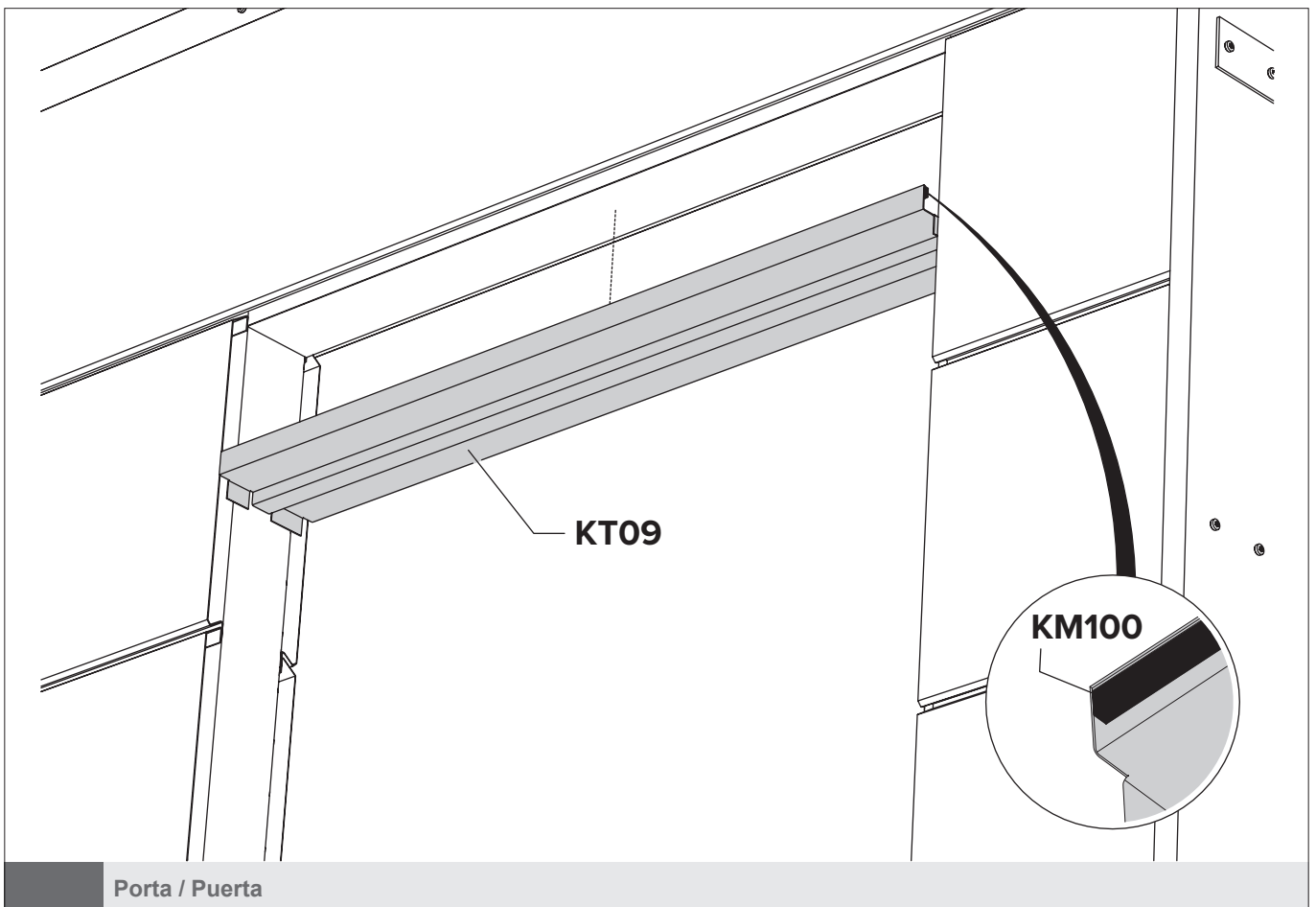
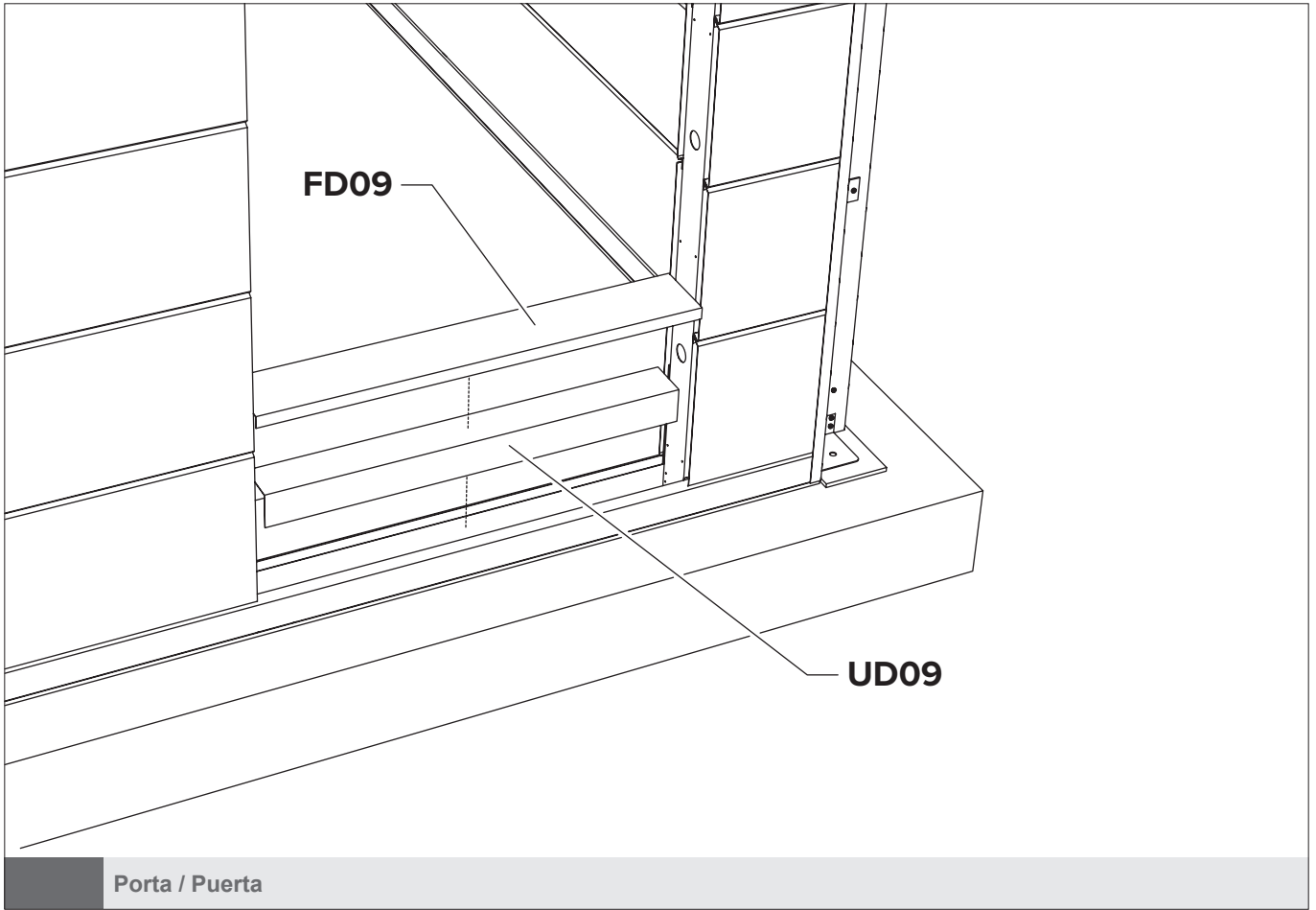

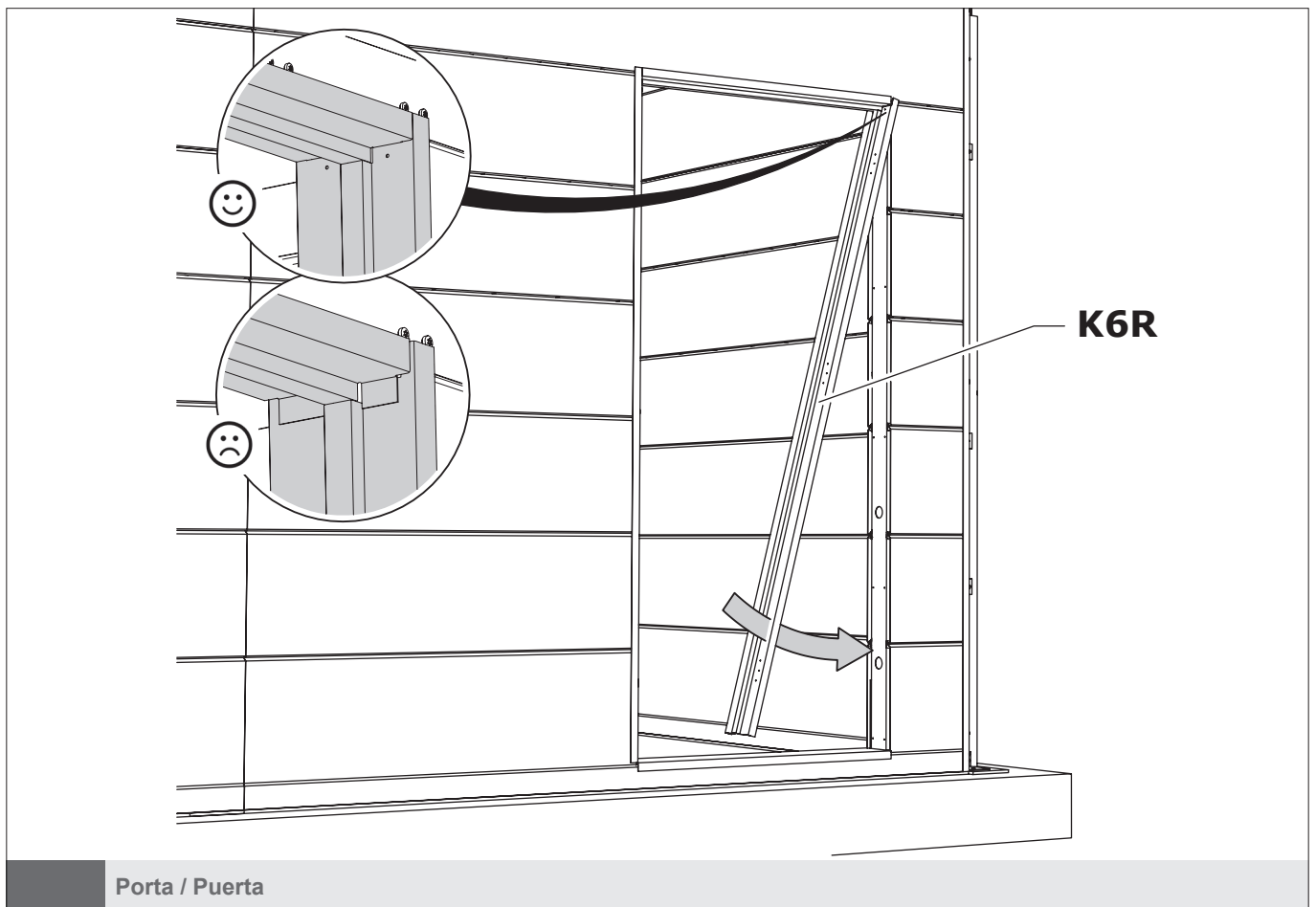
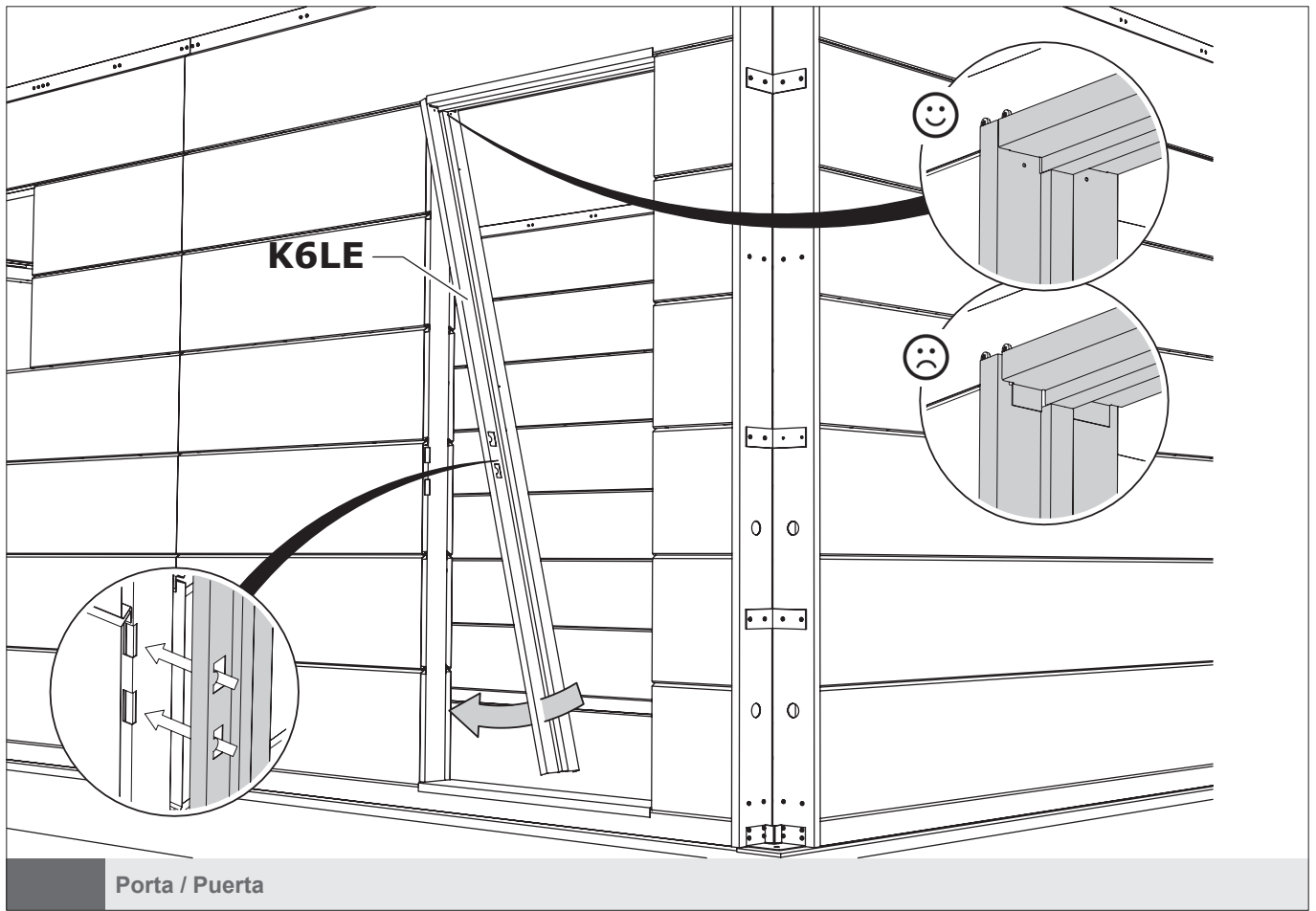

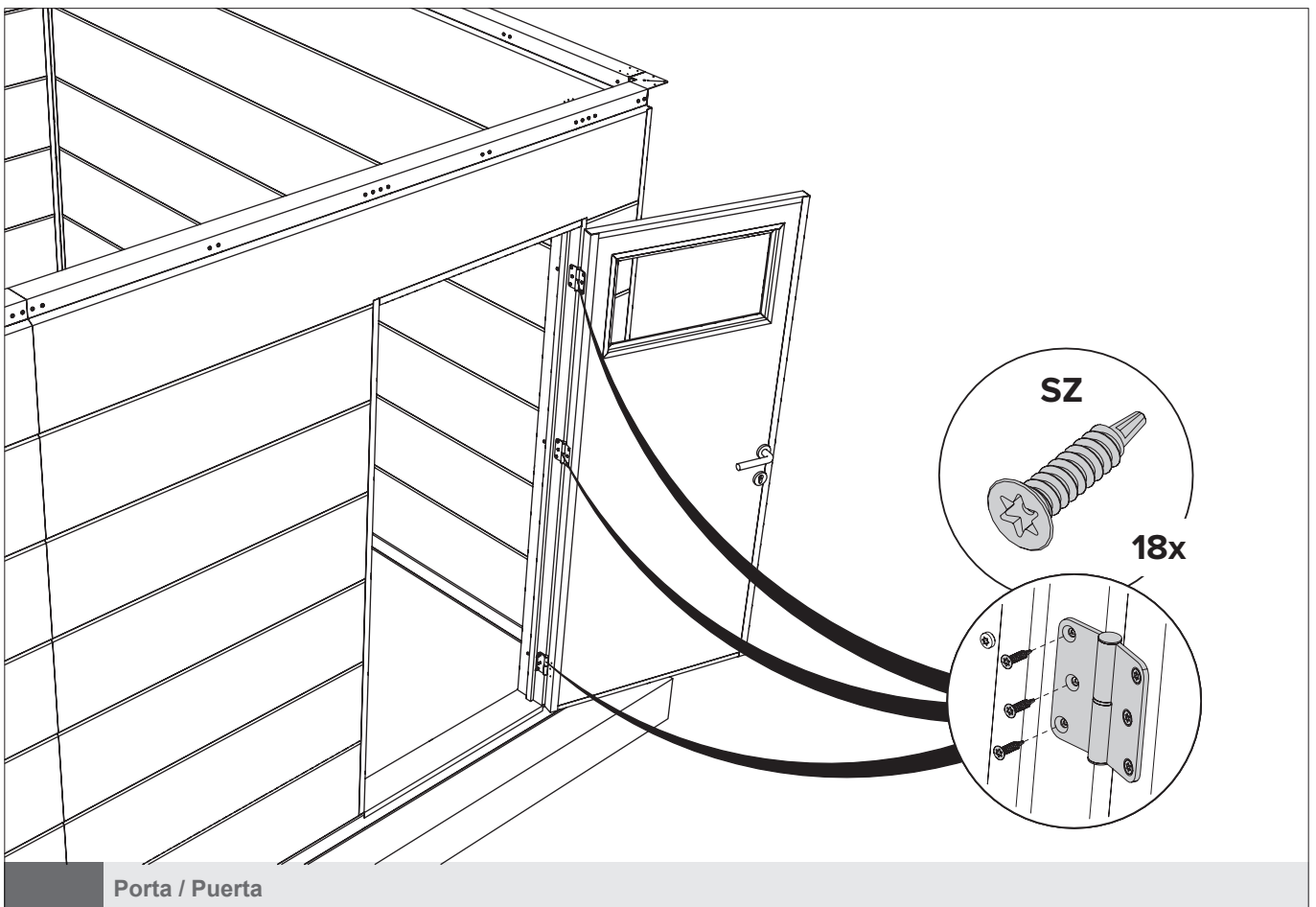

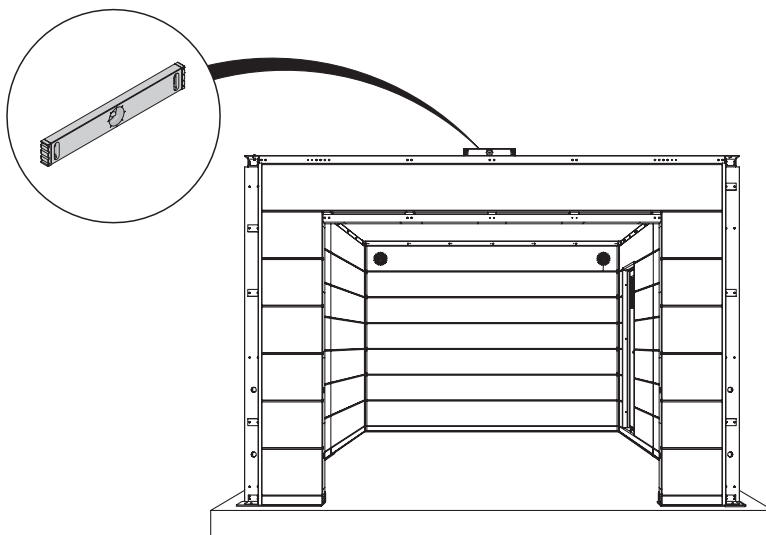
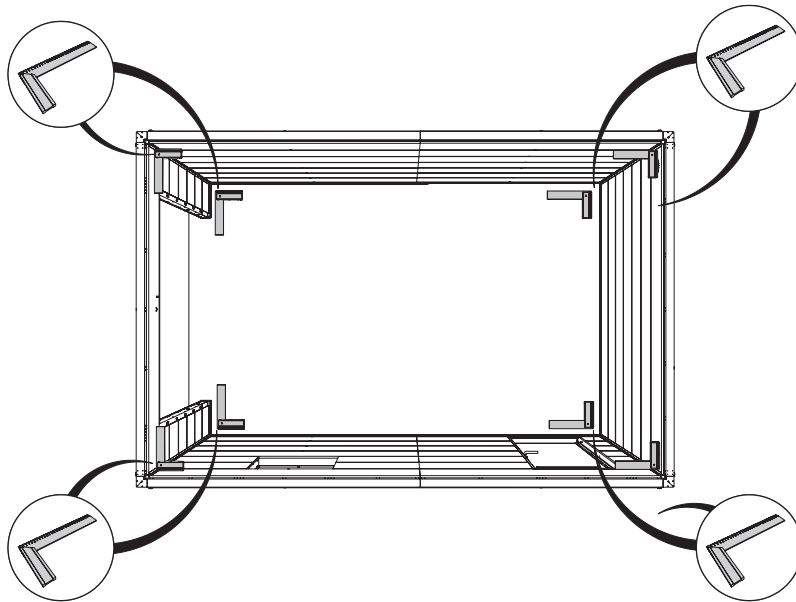
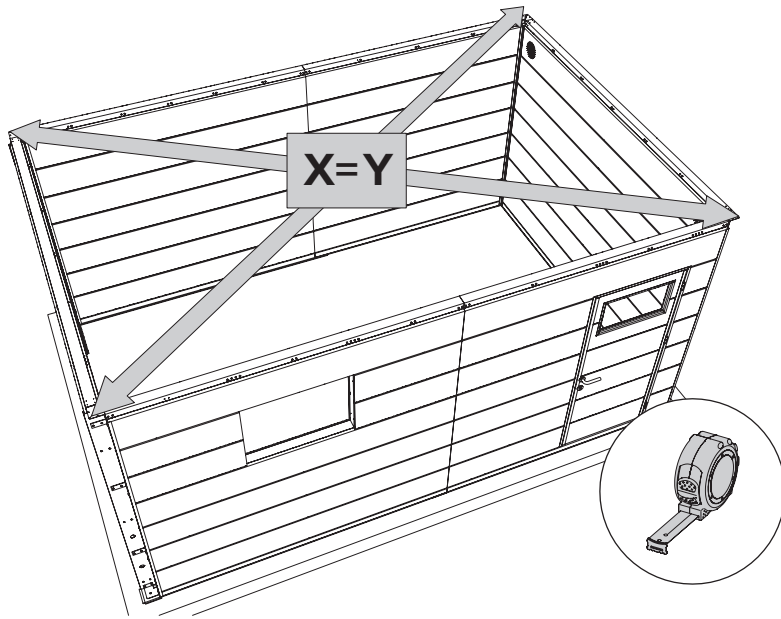

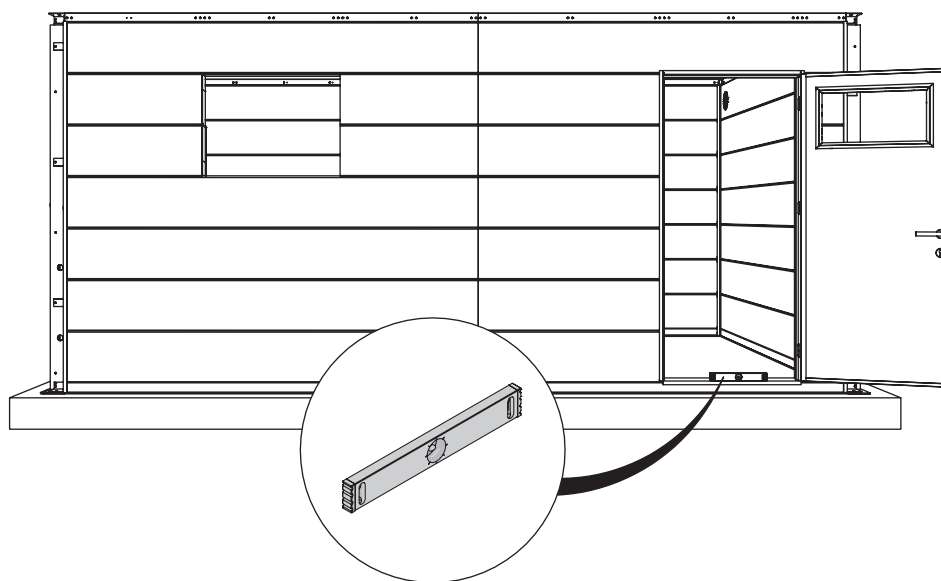
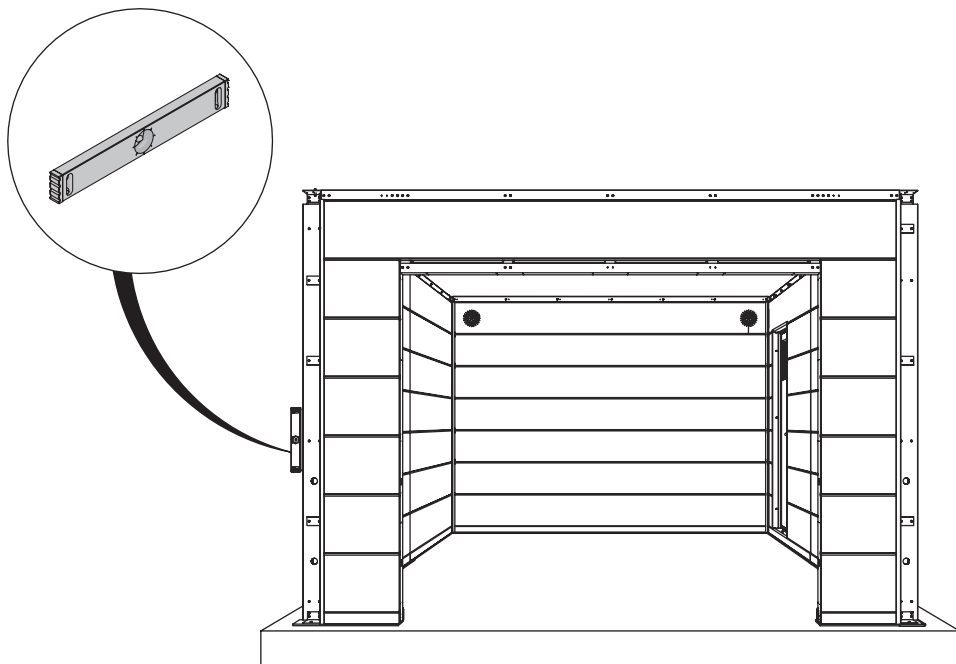

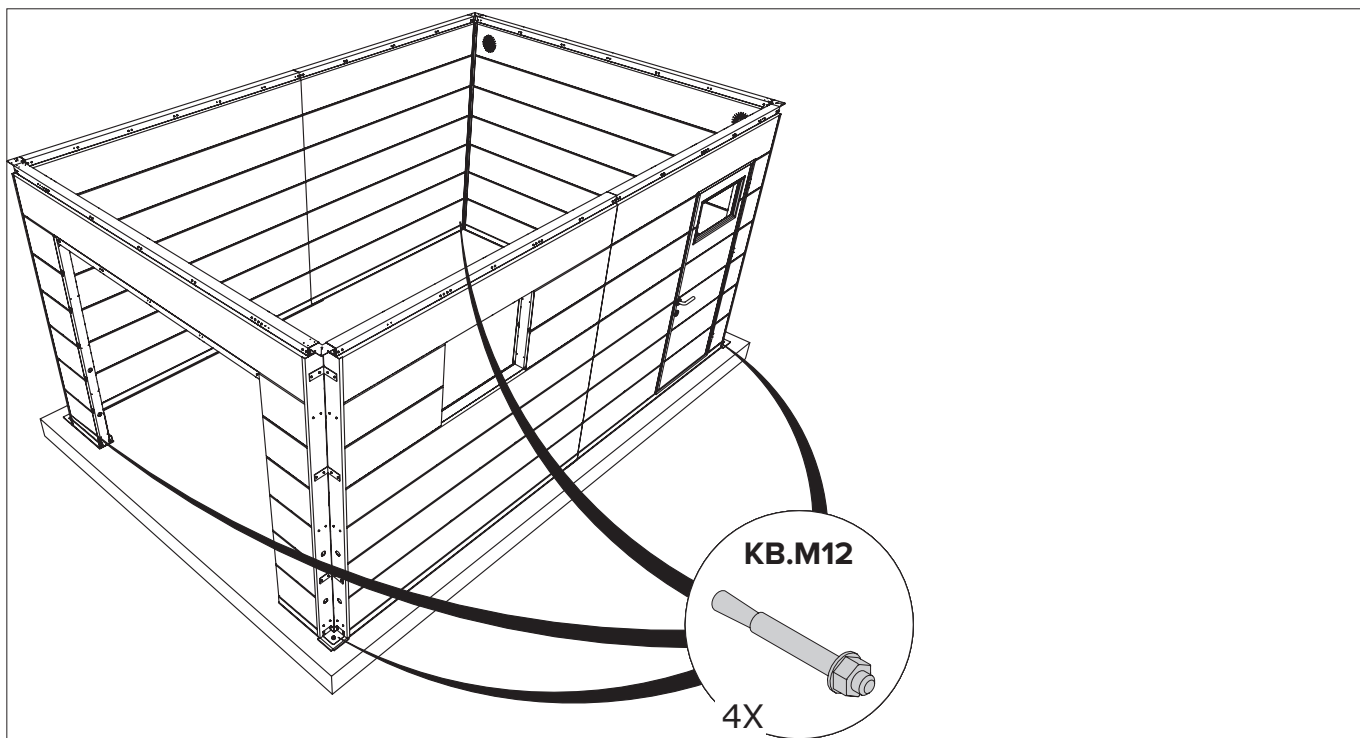

O exemplo é para piso em cimento. Fixe a garagem de acordo com as boas práticas.
El ejemplo es para piso en cemento. Fije a garaje de acuerdo con las buenas prácticas.

Ancoragem / Anclaje

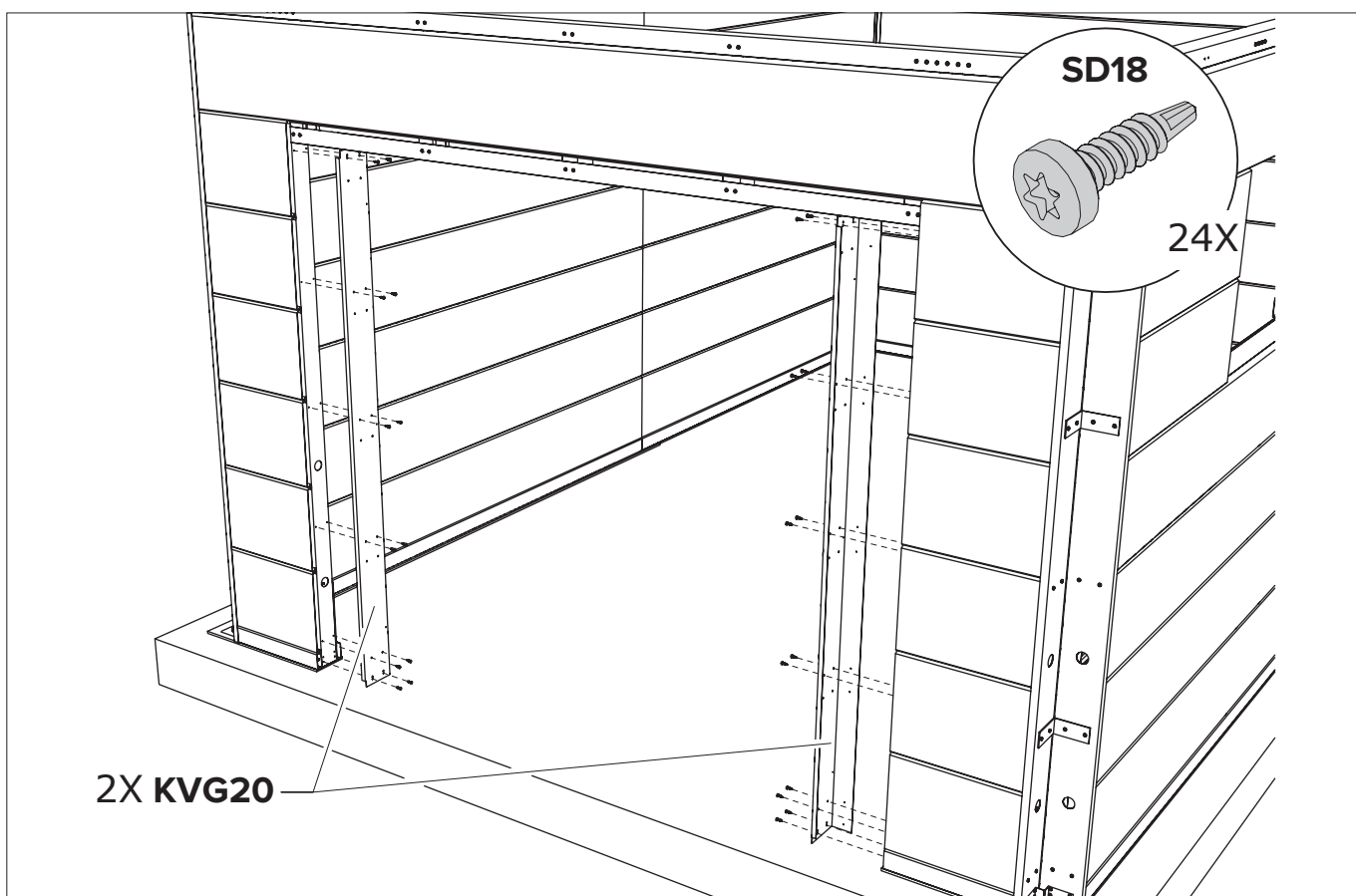

A **Porta seccionada / Puerta seccional**

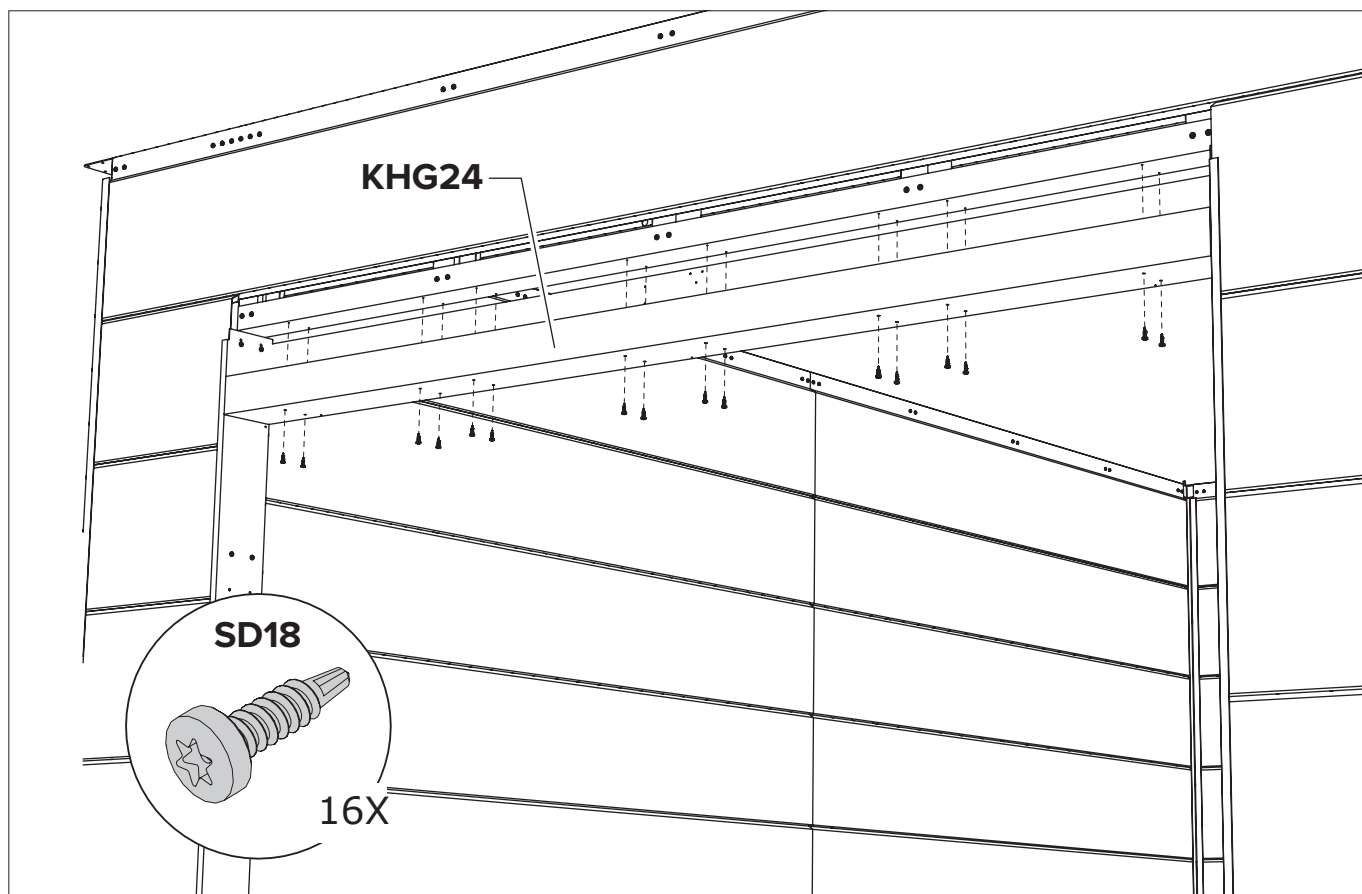

A Porta seccionada / Puerta seccional

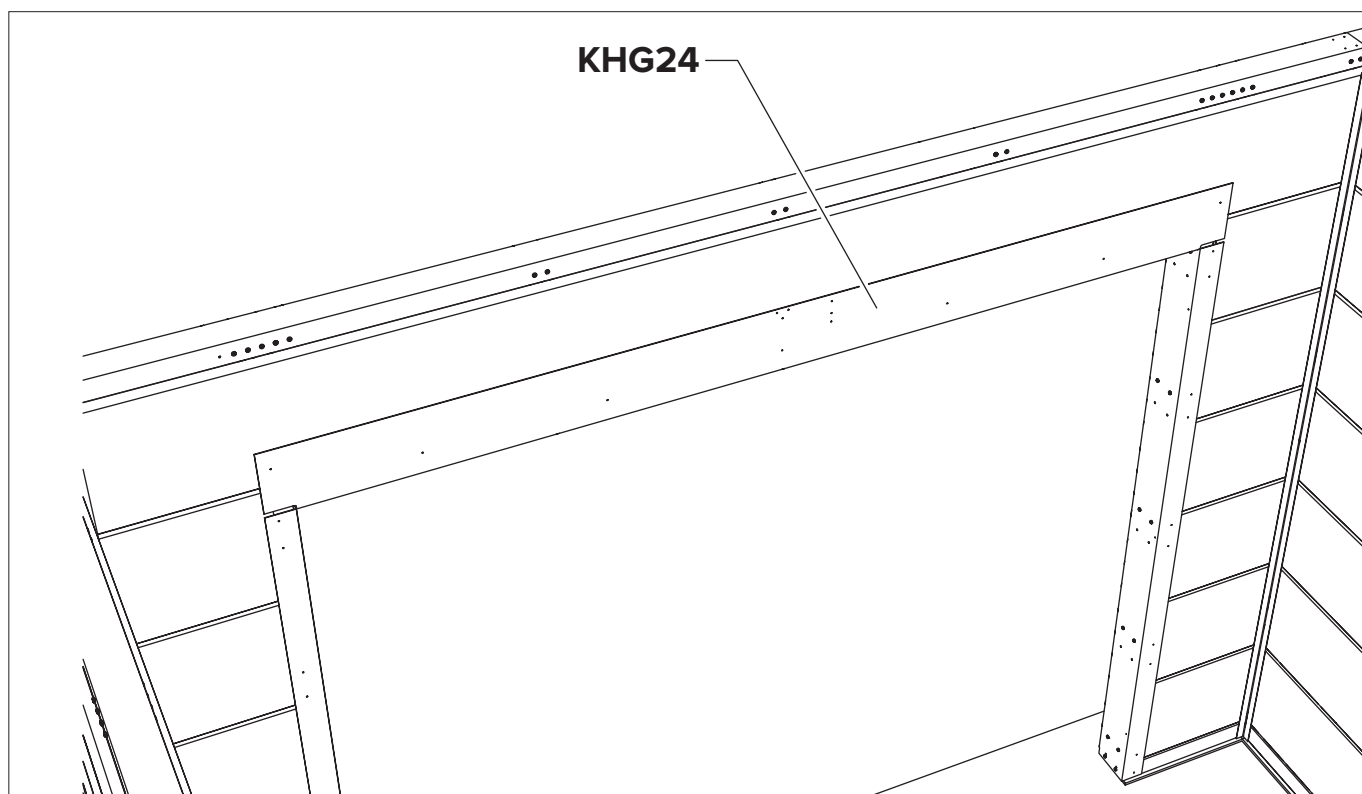

A Porta seccionada / Puerta seccional

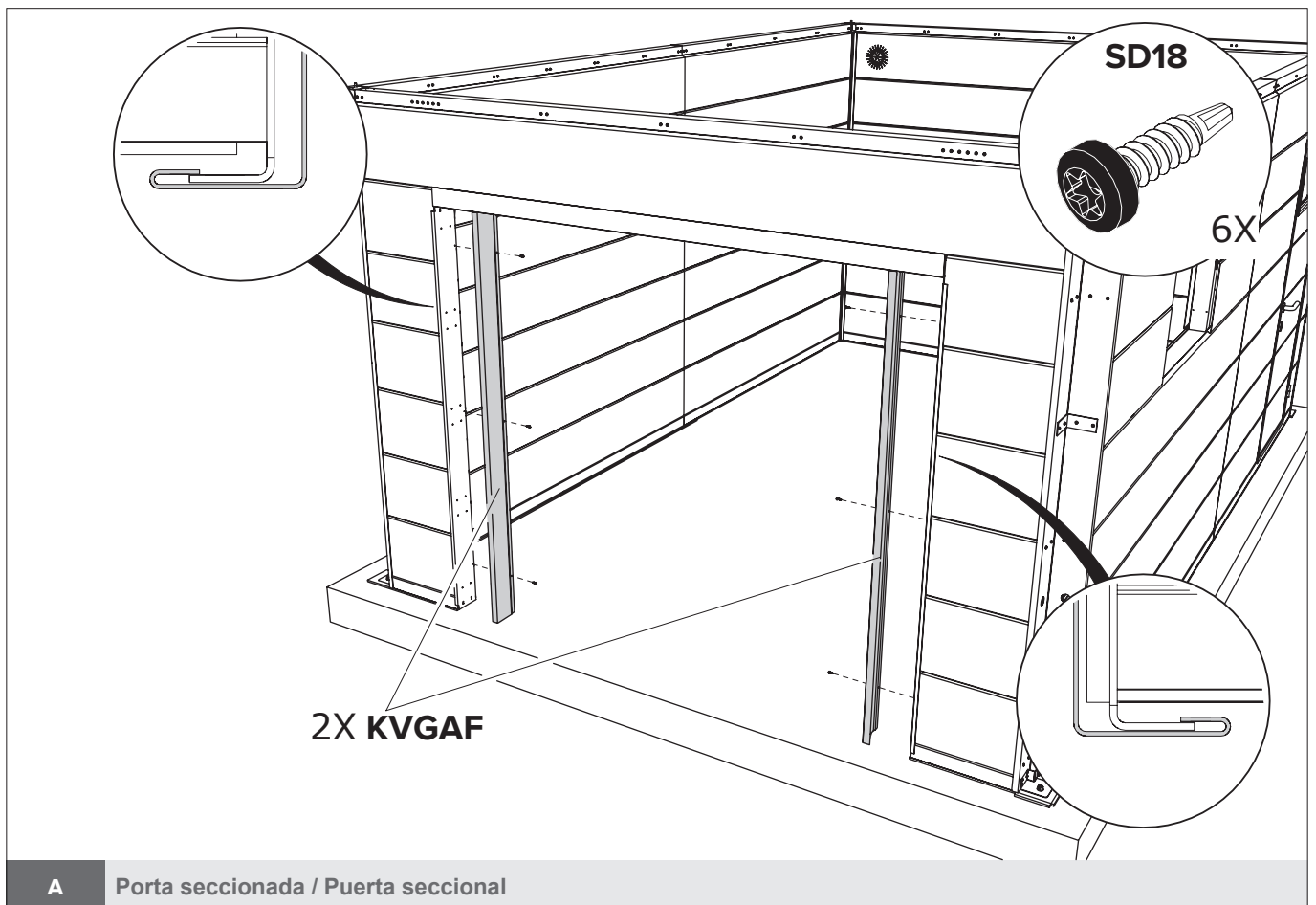
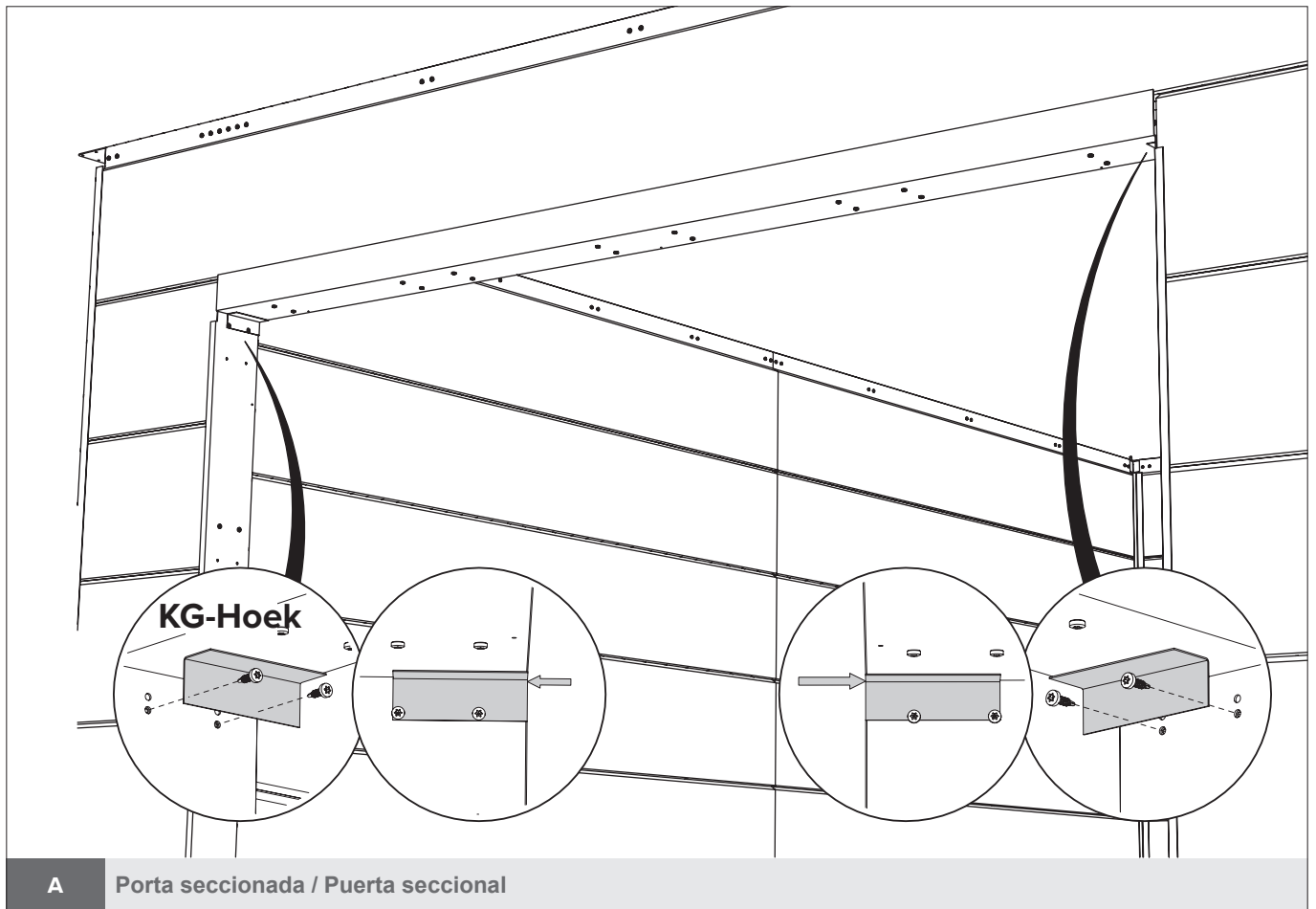

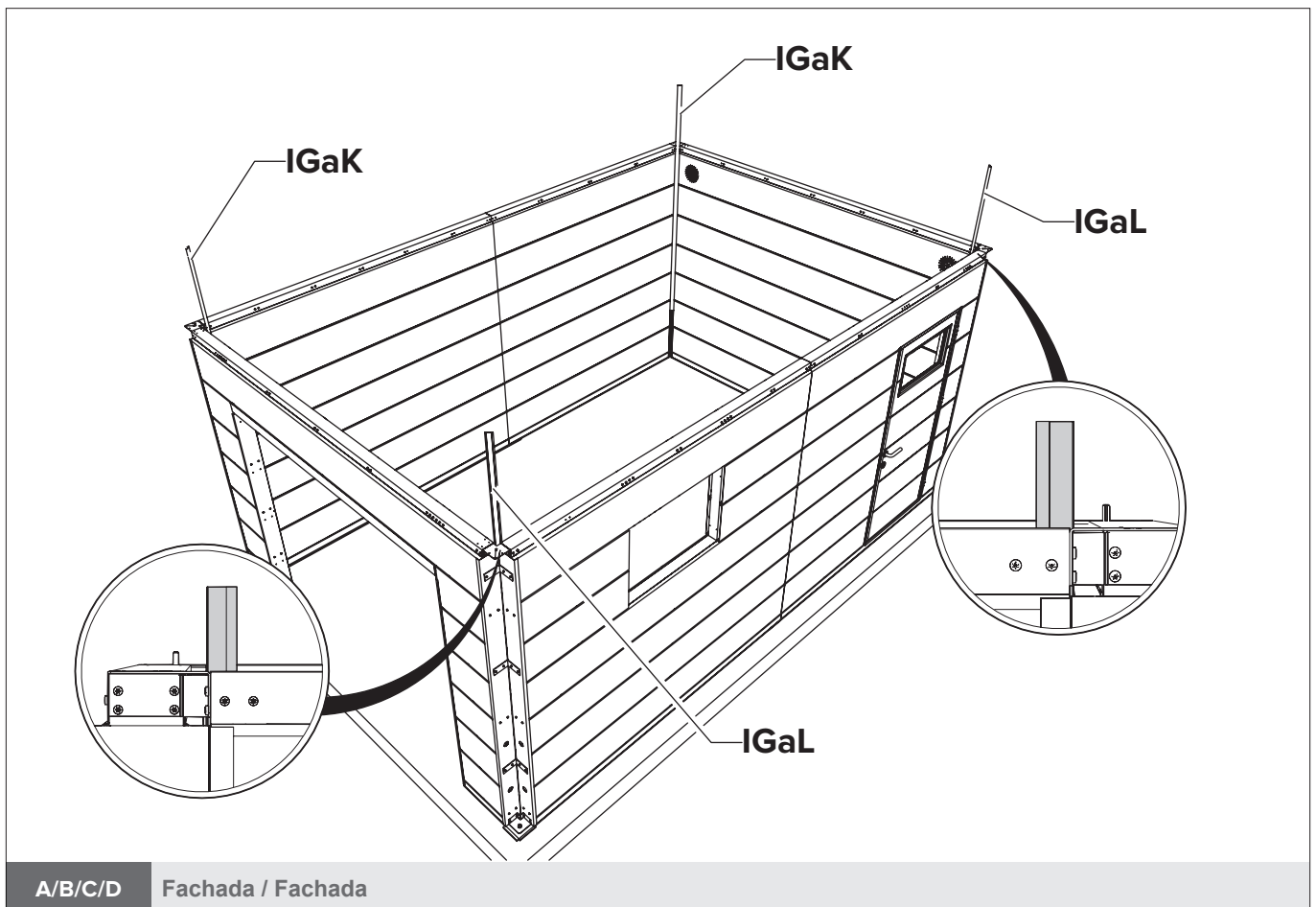
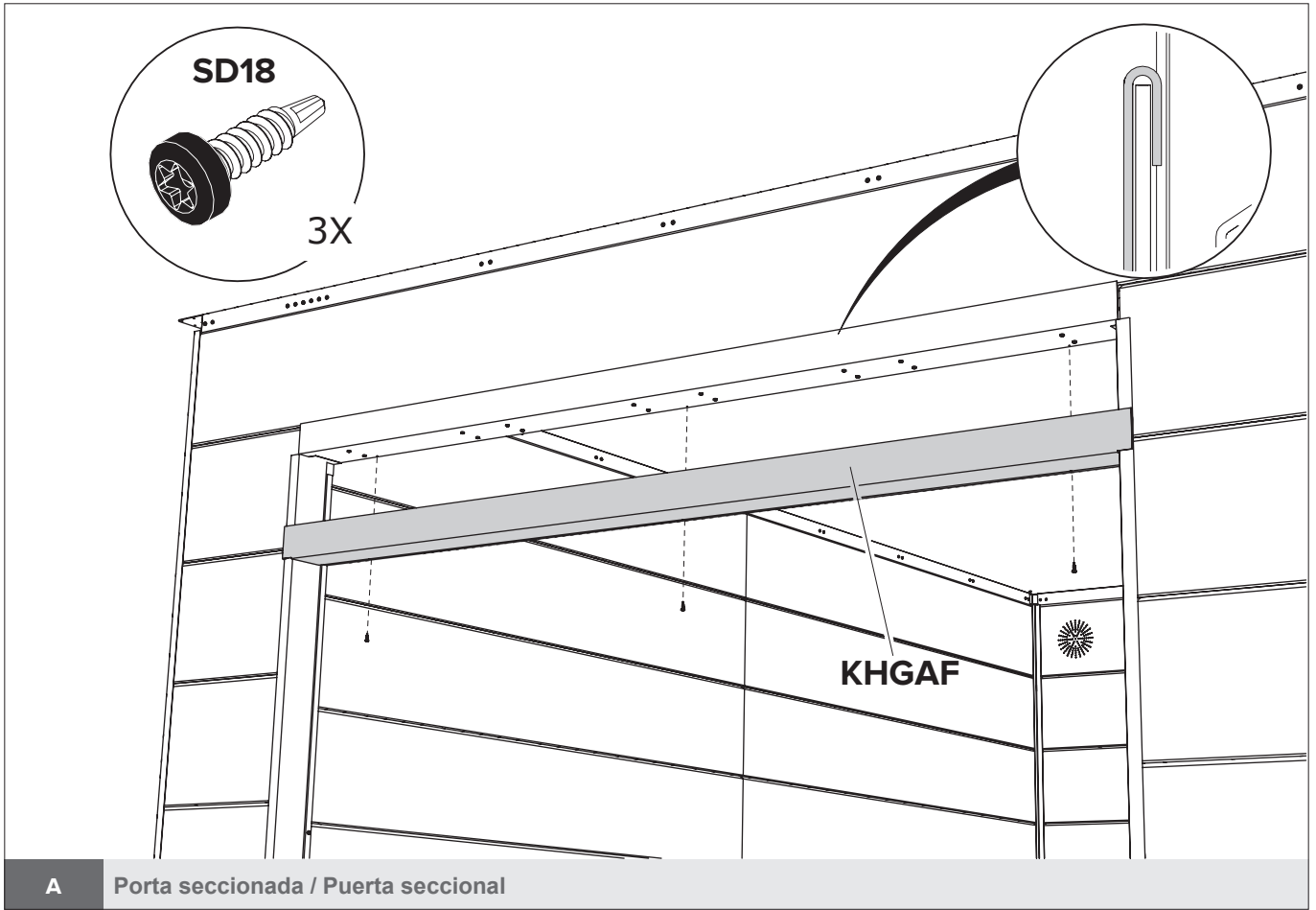

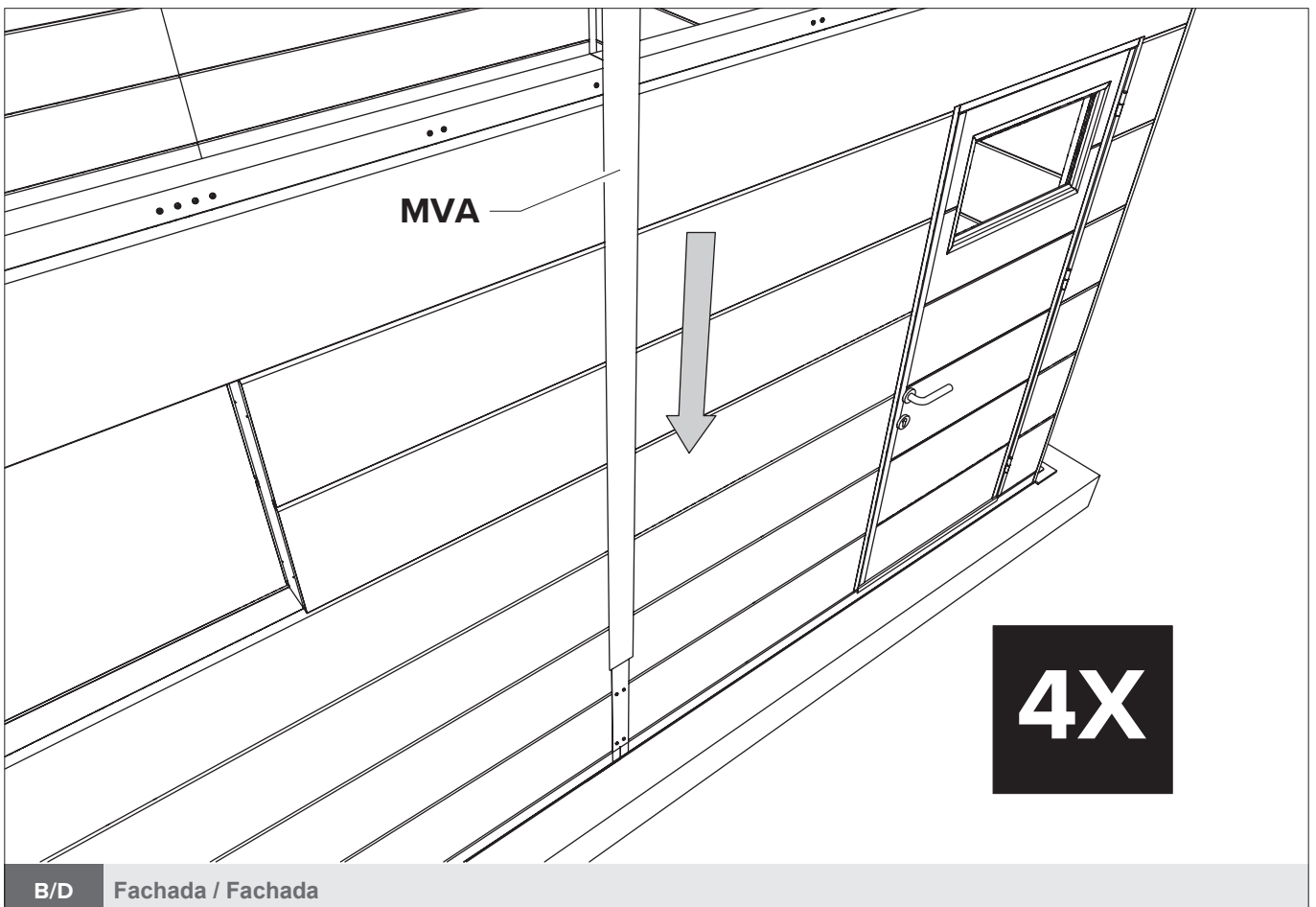
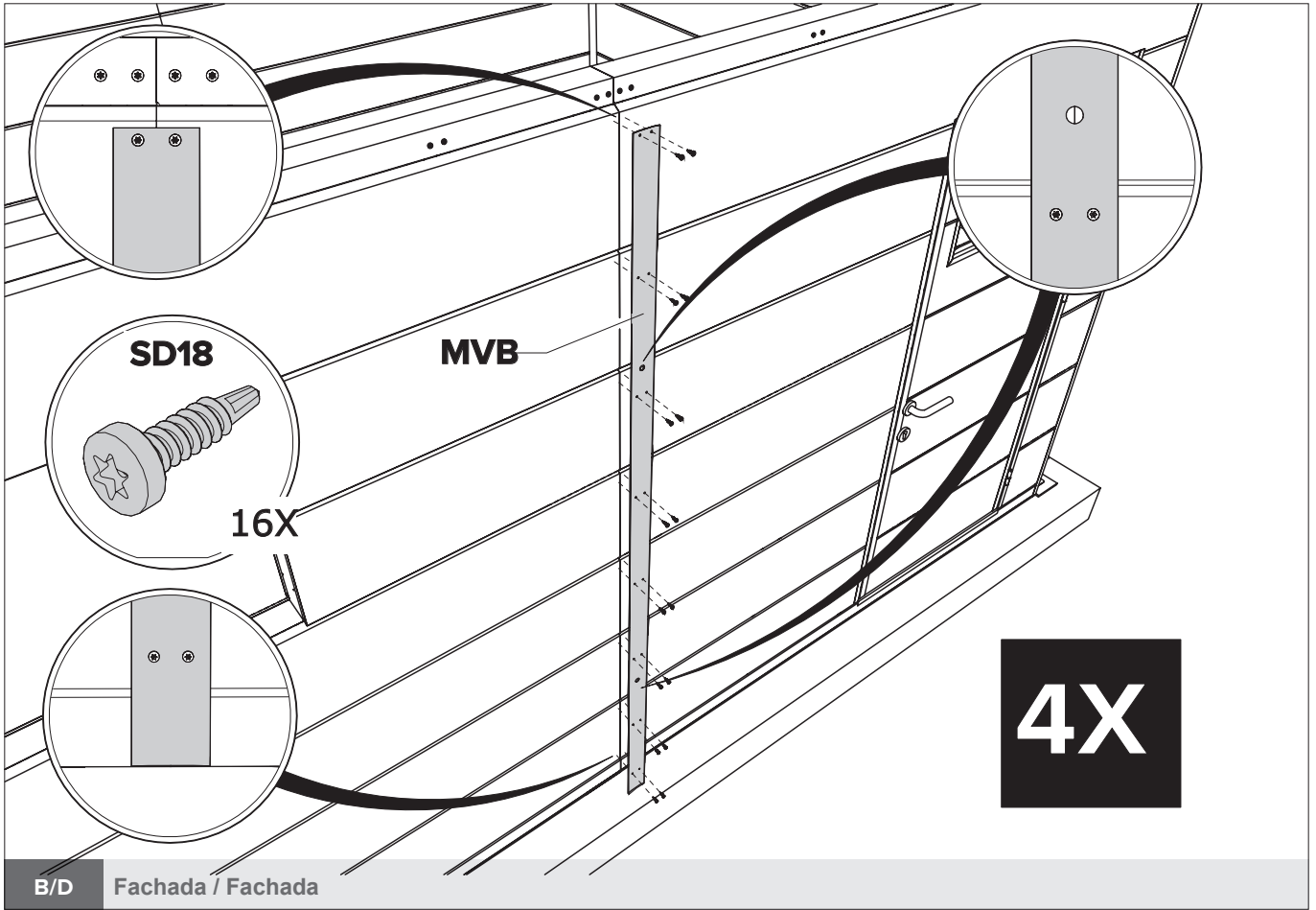

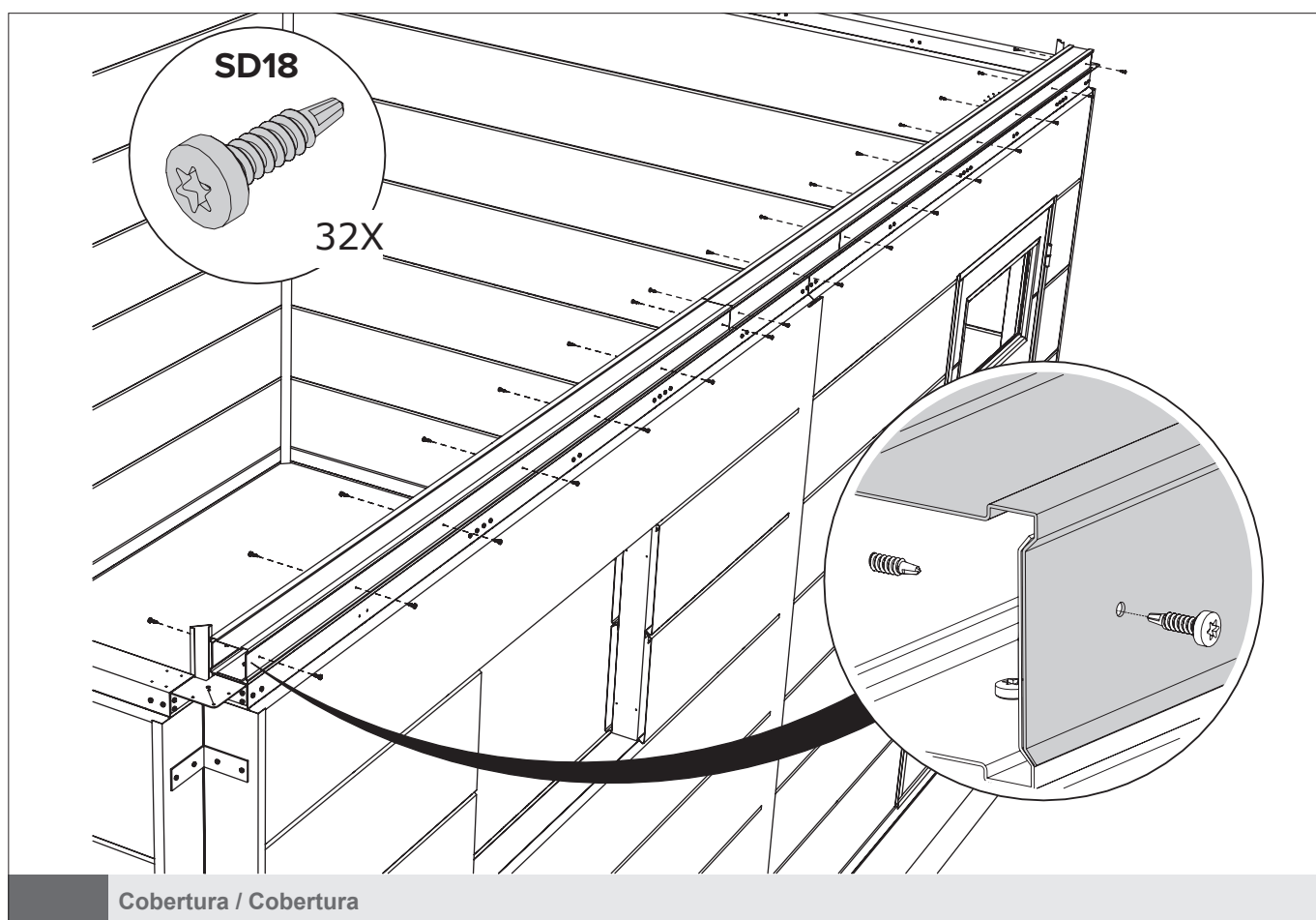
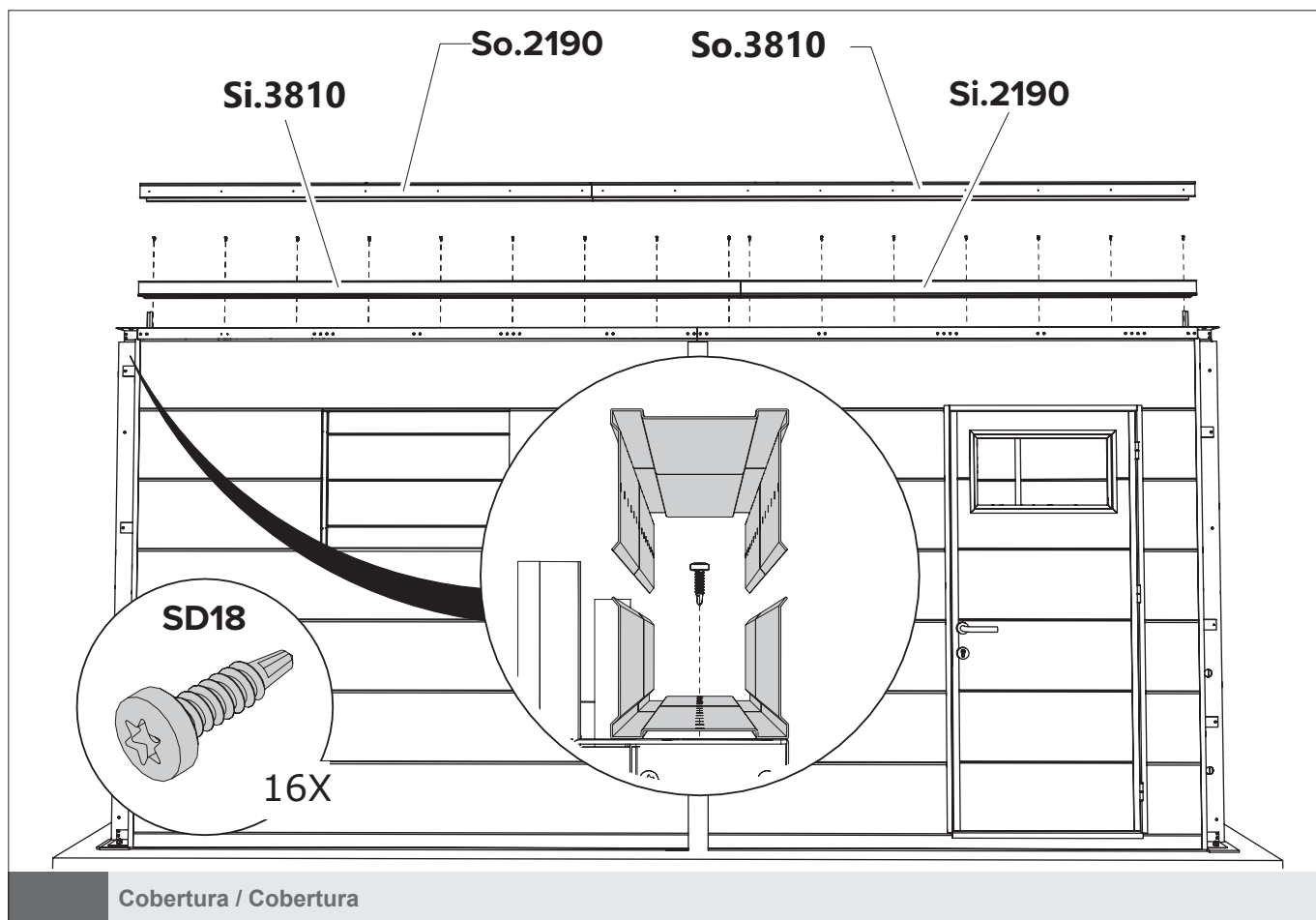

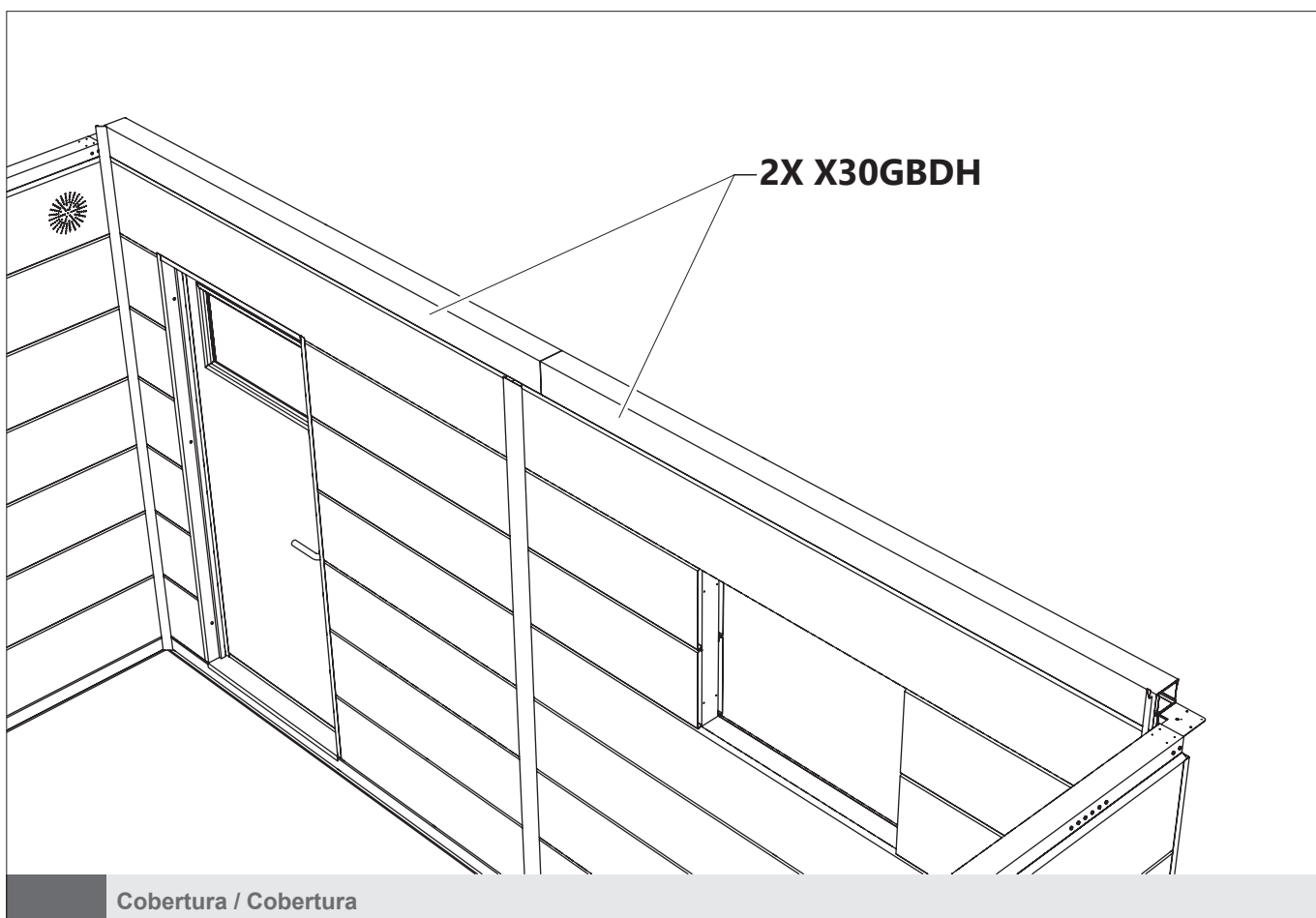
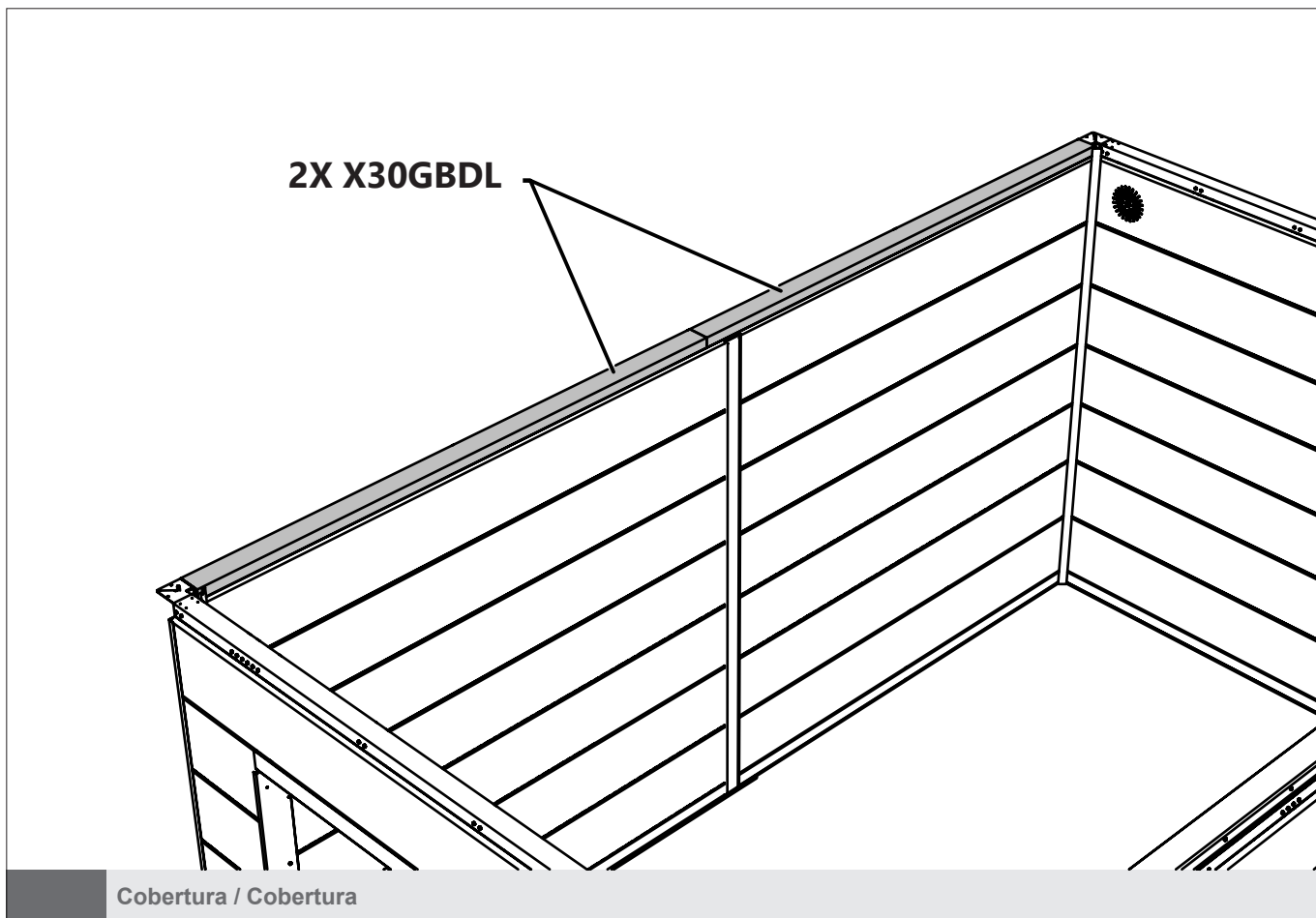

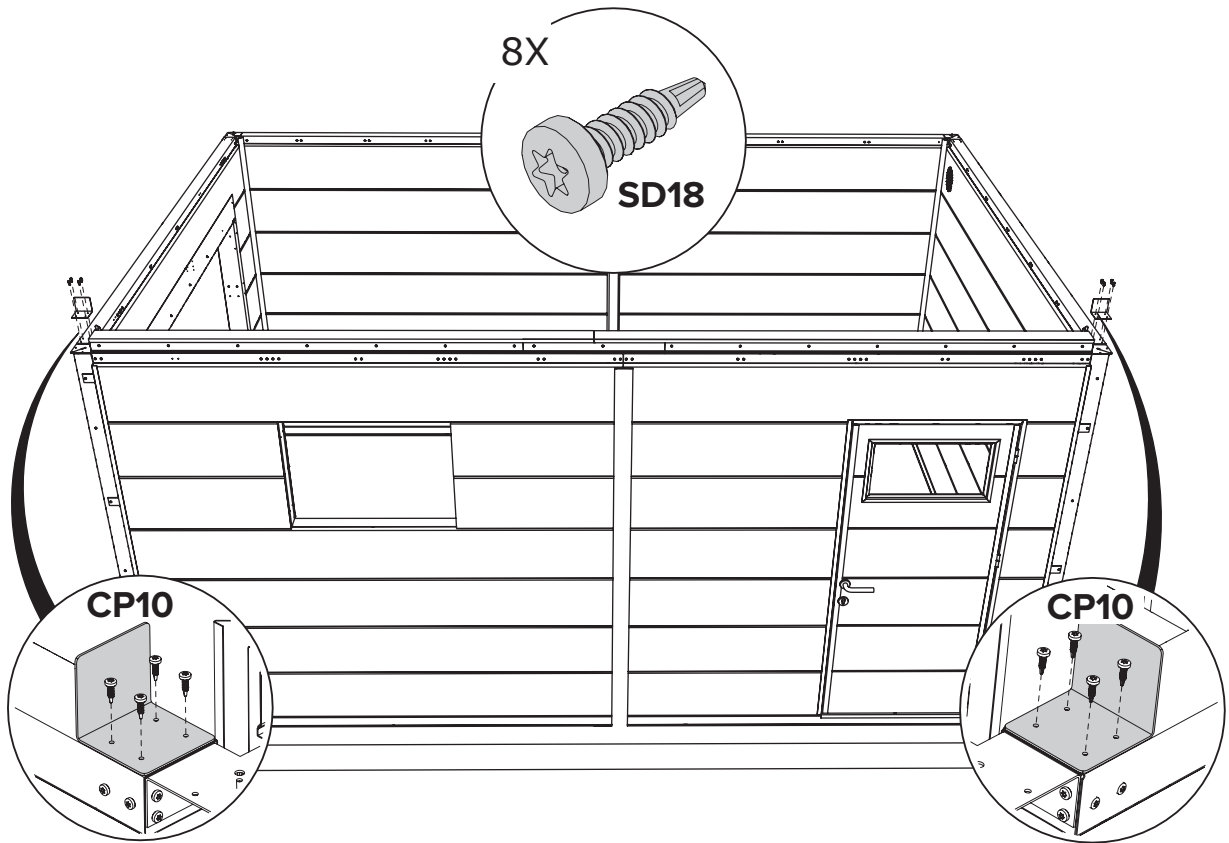

Cobertura / Cobertura

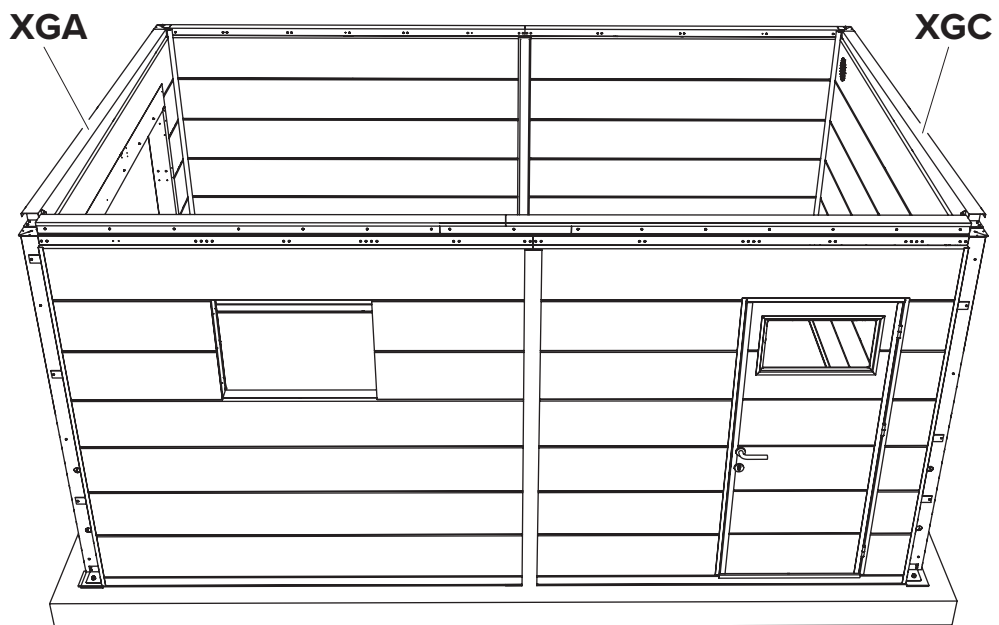

Cobertura / Cobertura

Remova a película / Remova a película

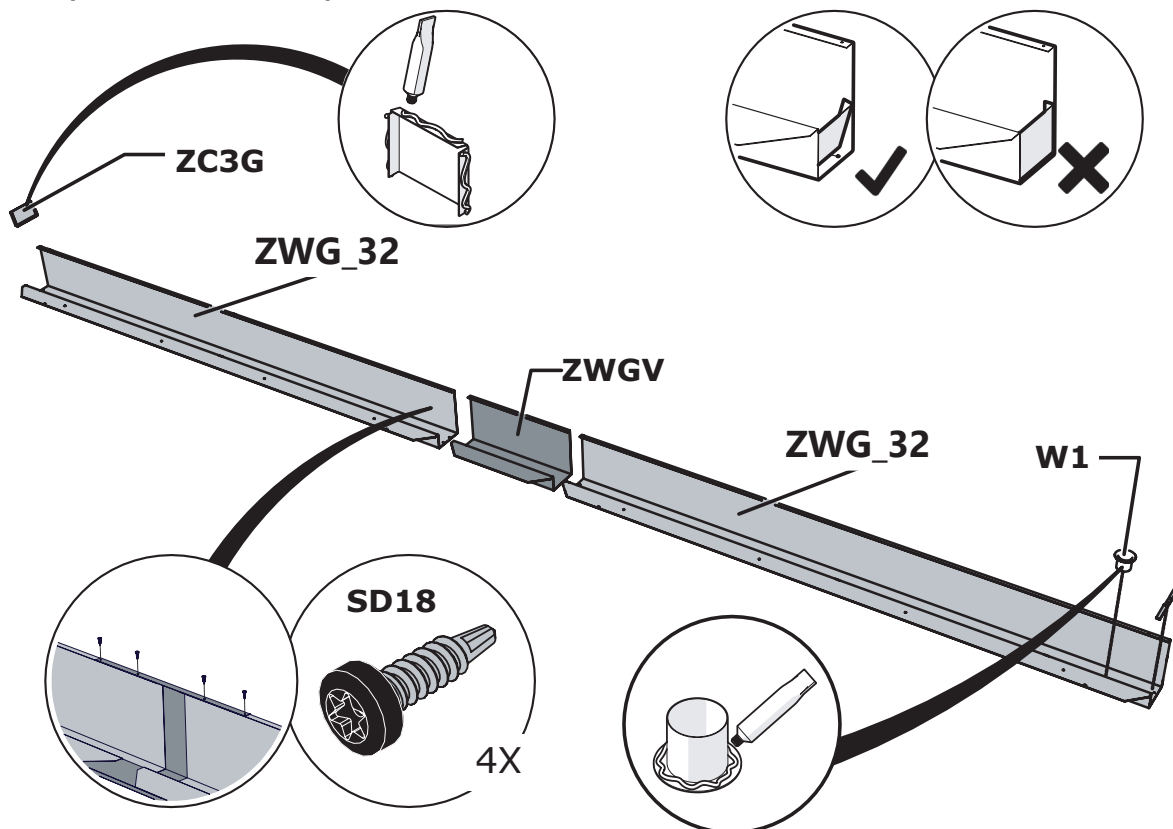

Cobertura / Cobertura

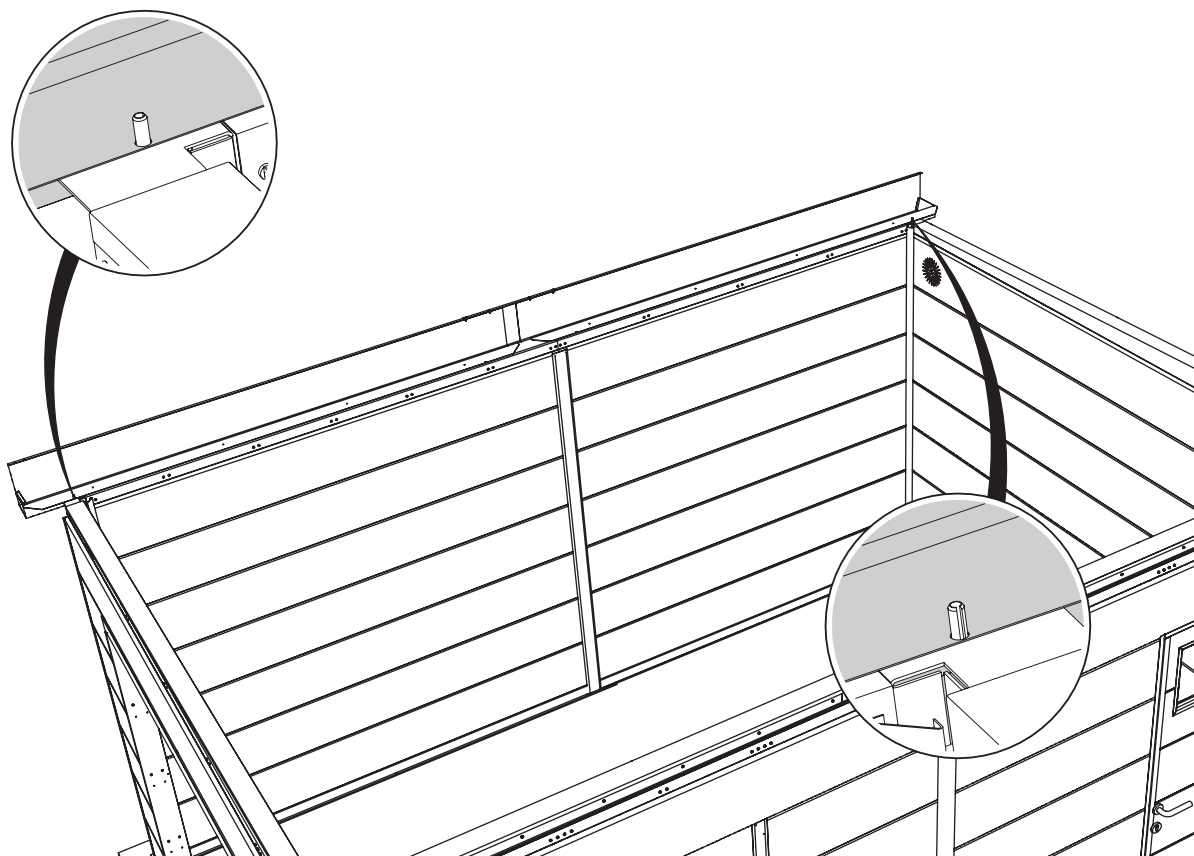

Cobertura / Cobertura

A direção da inclinação pode ser ajustada de acordo com sua preferência. Neste exemplo, a inclinação da cobertura é da direita para a esquerda. **Também é possível fazer a inclinação da esquerda para a direita.**

Comece instalando os painéis da cobertura e verifique a posição e o paralelismo às paredes.

Observe que os perfis de acabamento do beiral da cobertura somente são corretamente colocados se os painéis do telhado estiverem na posição correta, alinhados corretamente e as esquinas no topo das paredes estiverem em um ângulo perfeito de 90 °.

Aperte os parafusos após a instalação do porta seccionada.

La dirección de la pendiente se puede ajustar según sus preferencias. En este ejemplo, la pendiente da cobertura es de derecha a izquierda. **También es posible realizar la pendiente de izquierda a derecha.**

Comience instalando los paneles da cobertura y verifique la posición y el paralelismo con las paredes.

Tenga en cuenta que los perfiles de acabado para los aleros da cobertura solo se colocan correctamente si los paneles del techo están en la posición correcta, alineados correctamente y las esquinas en la parte superior de las paredes están en un ángulo perfecto de 90 °.

Apriete los tornillos después de instalar la puerta seccional.

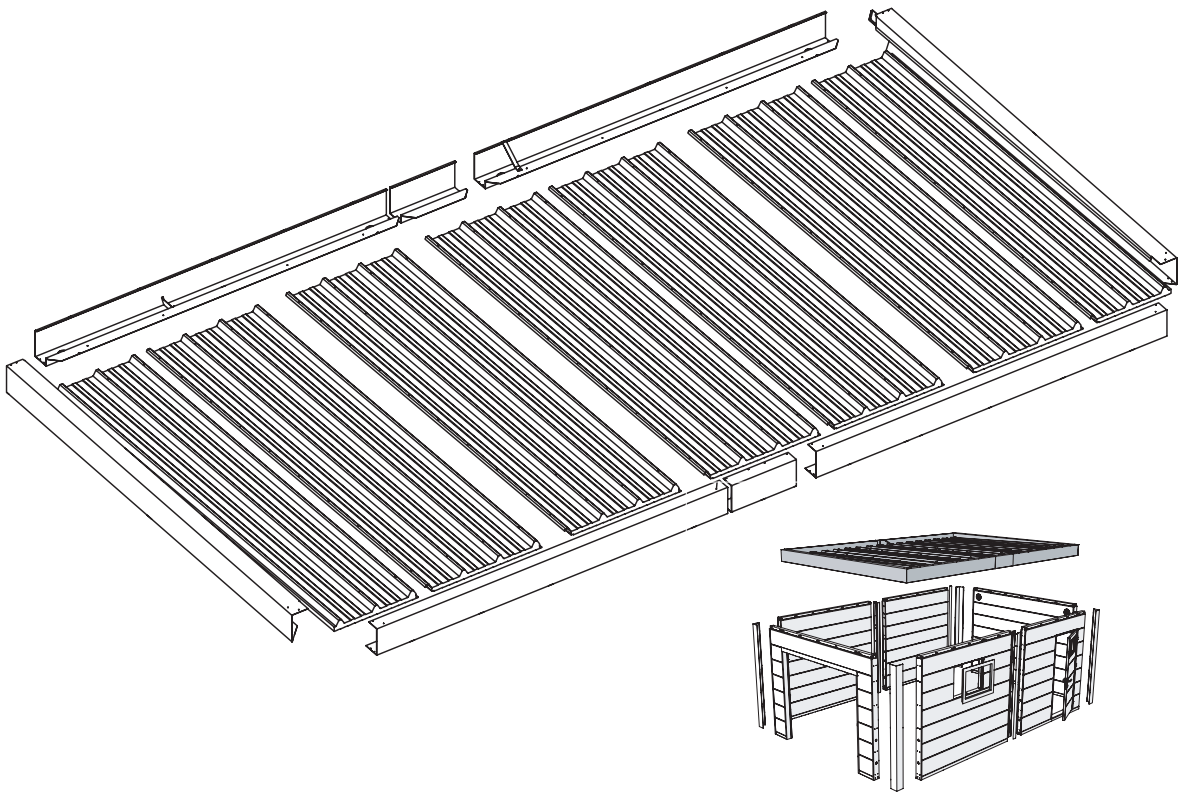

Cobertura / Cobertura

JI Garage 1

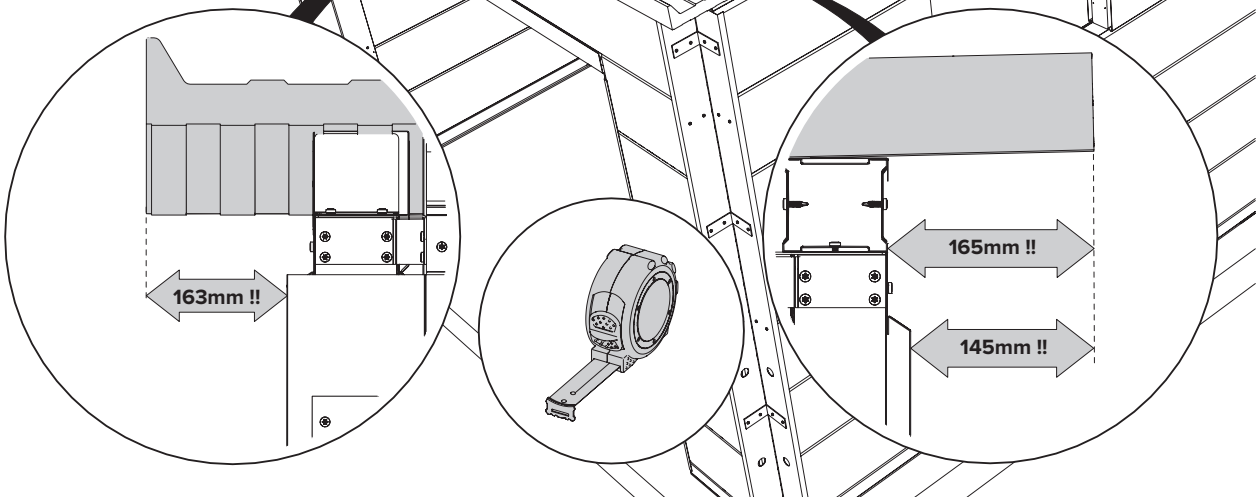

Cobertura / Cobertura

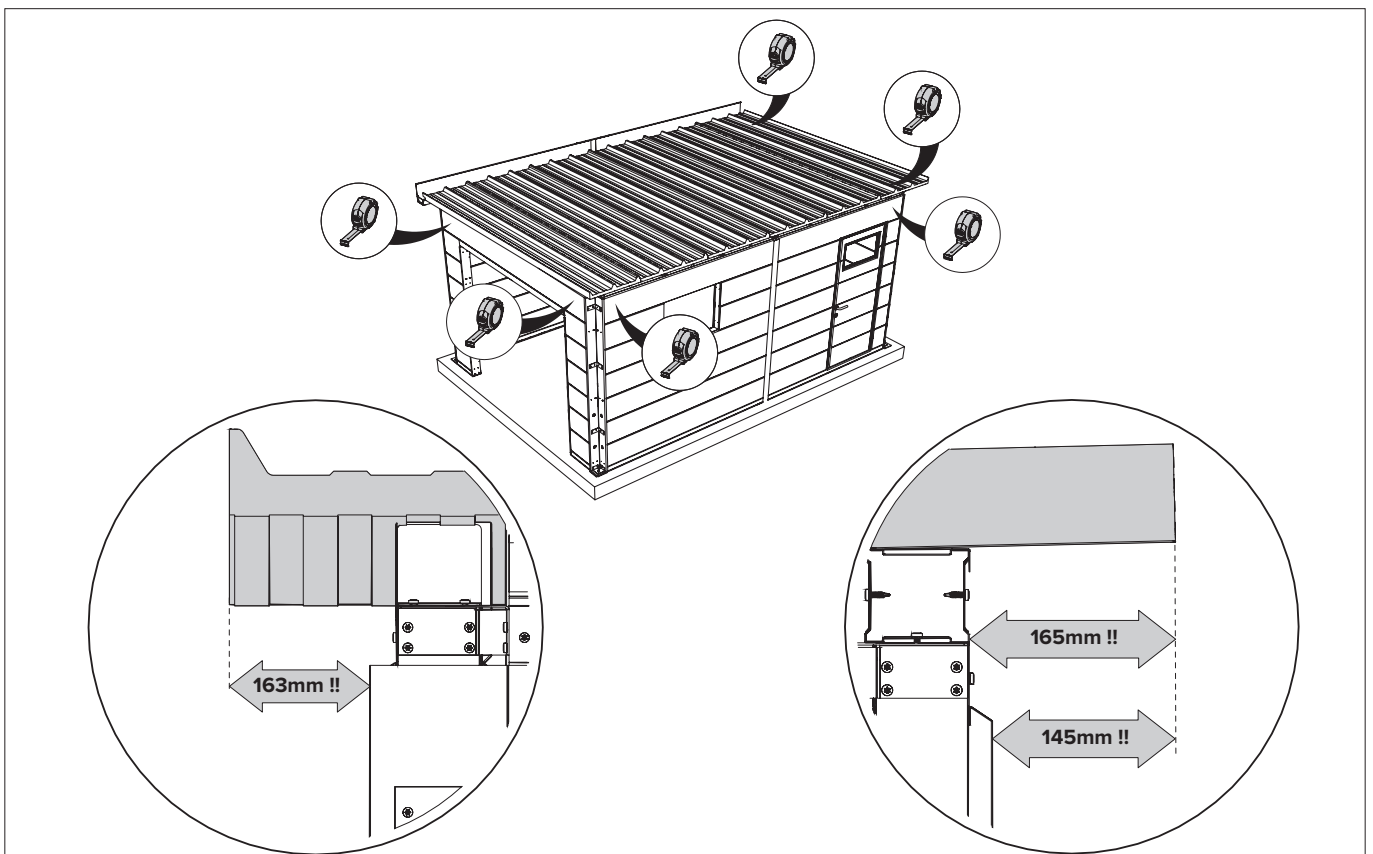
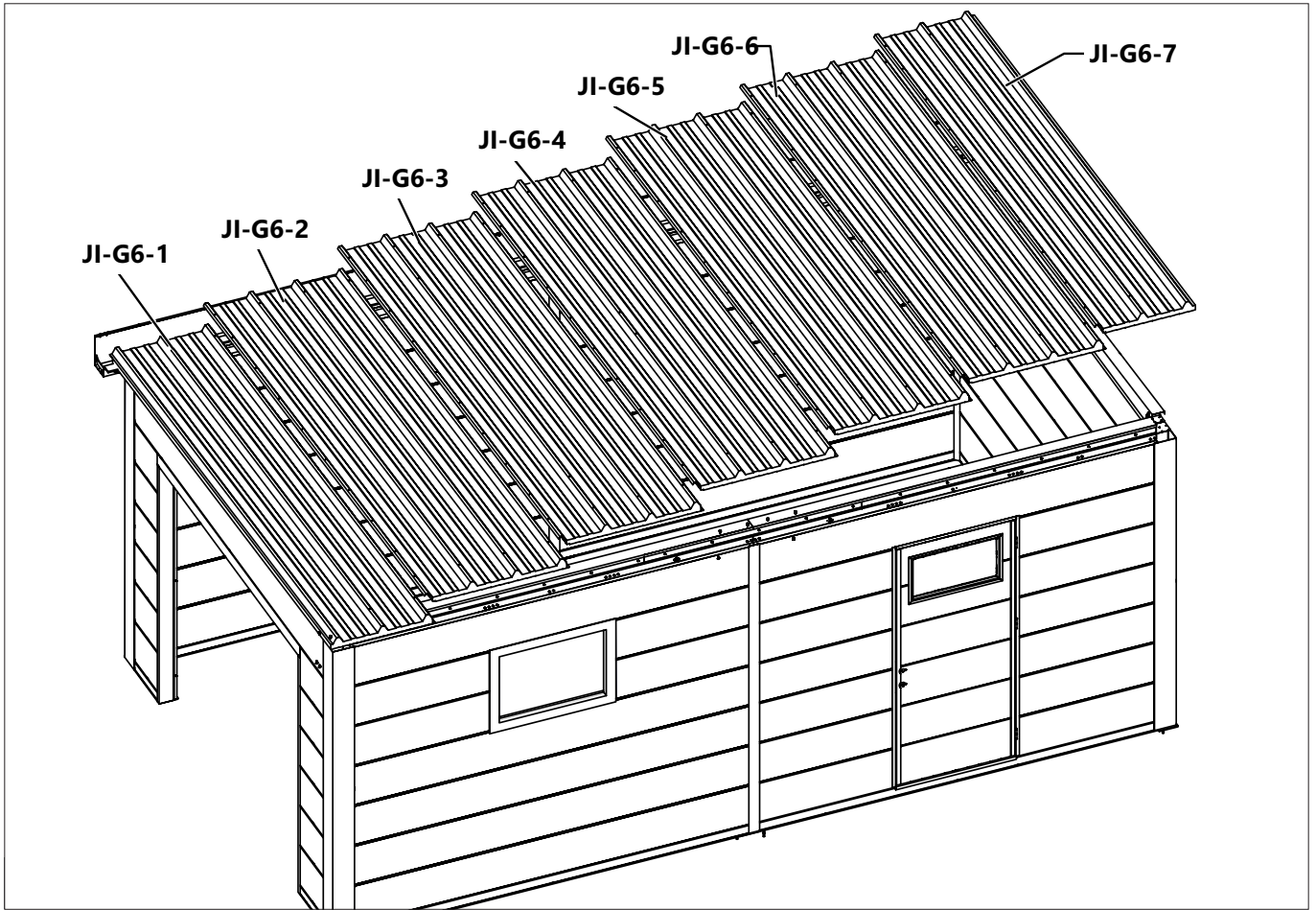

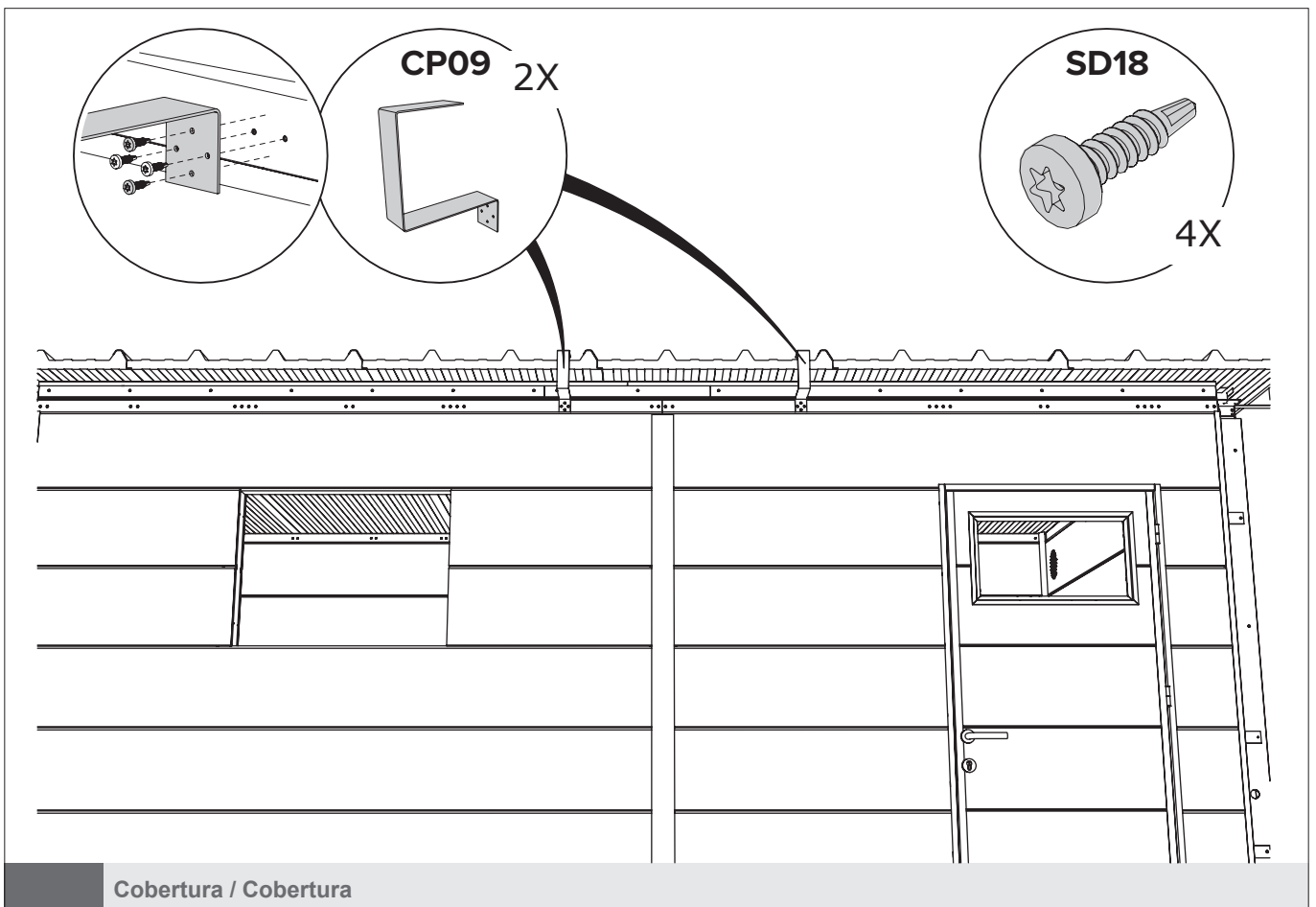
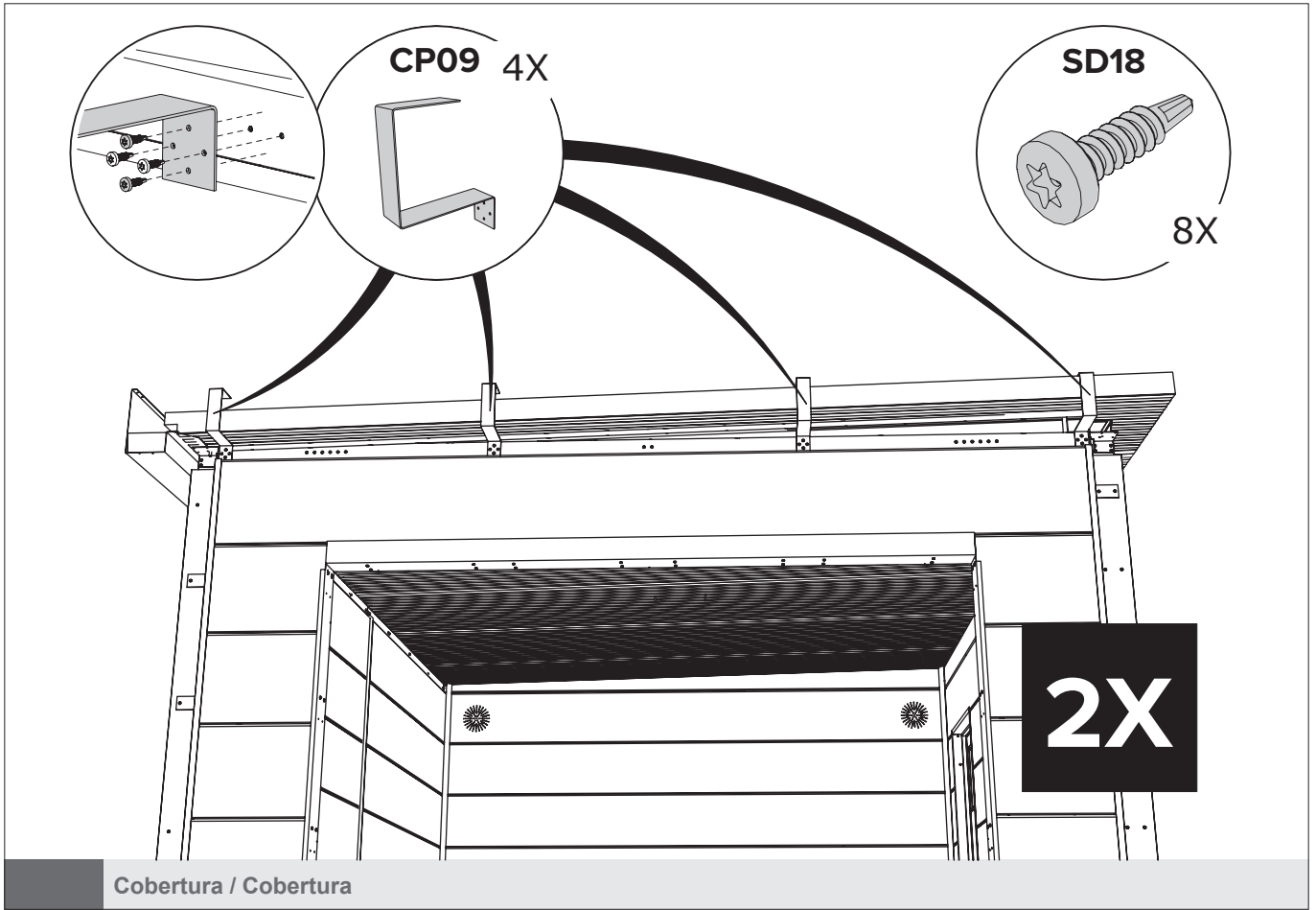

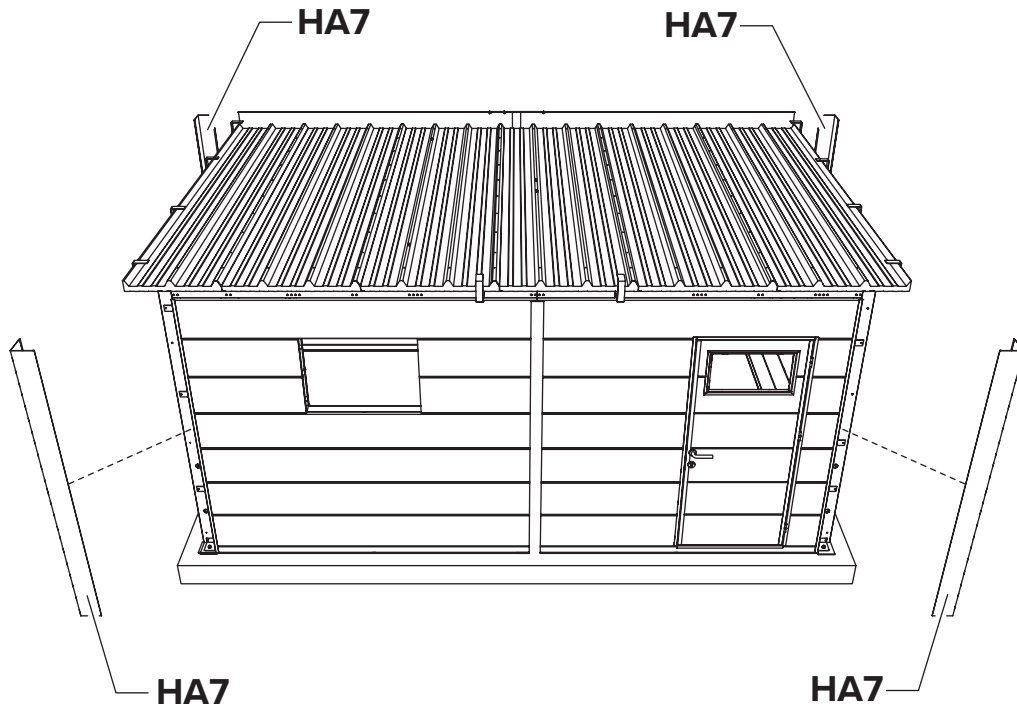

Esquina / Esquina

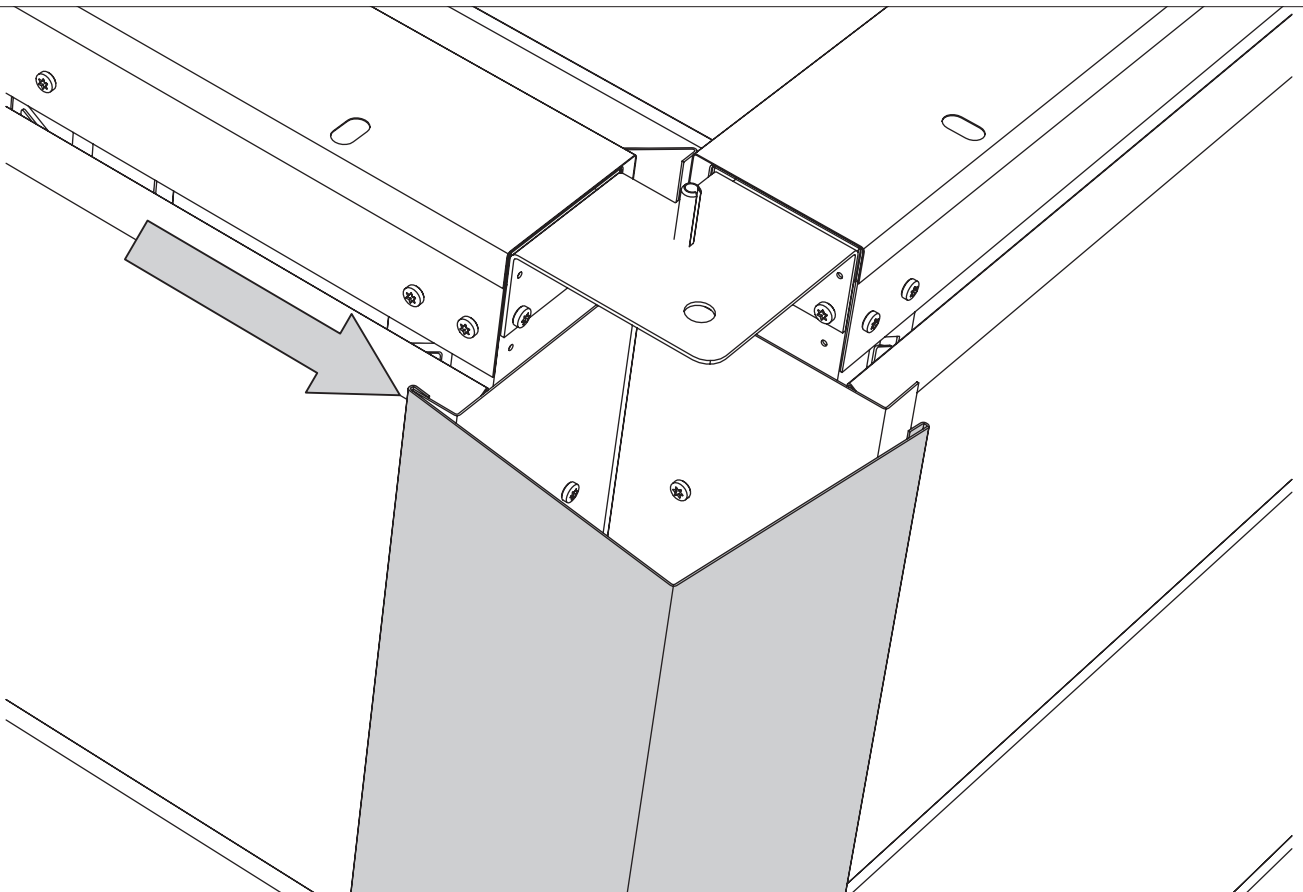

Esquina / Esquina

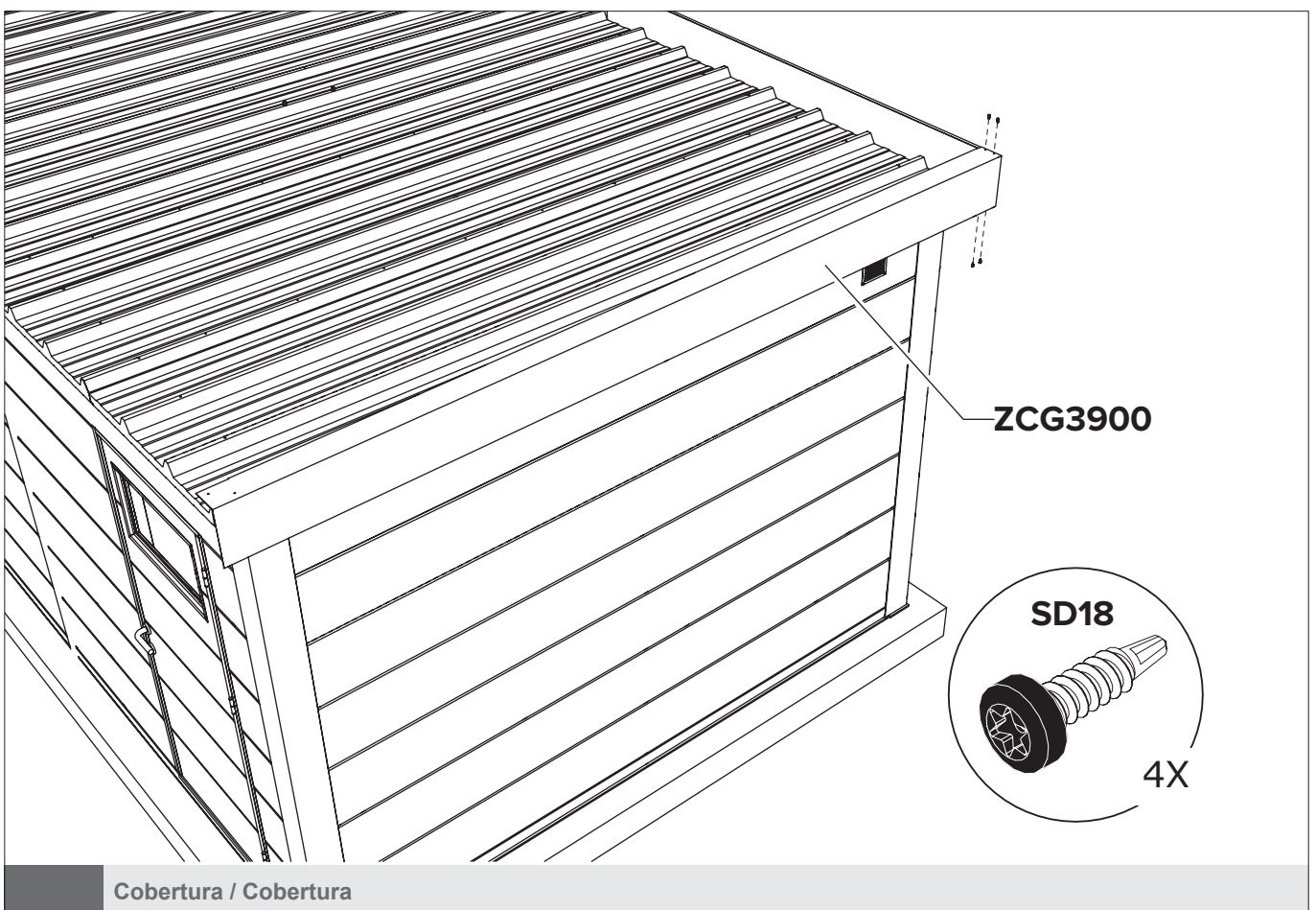
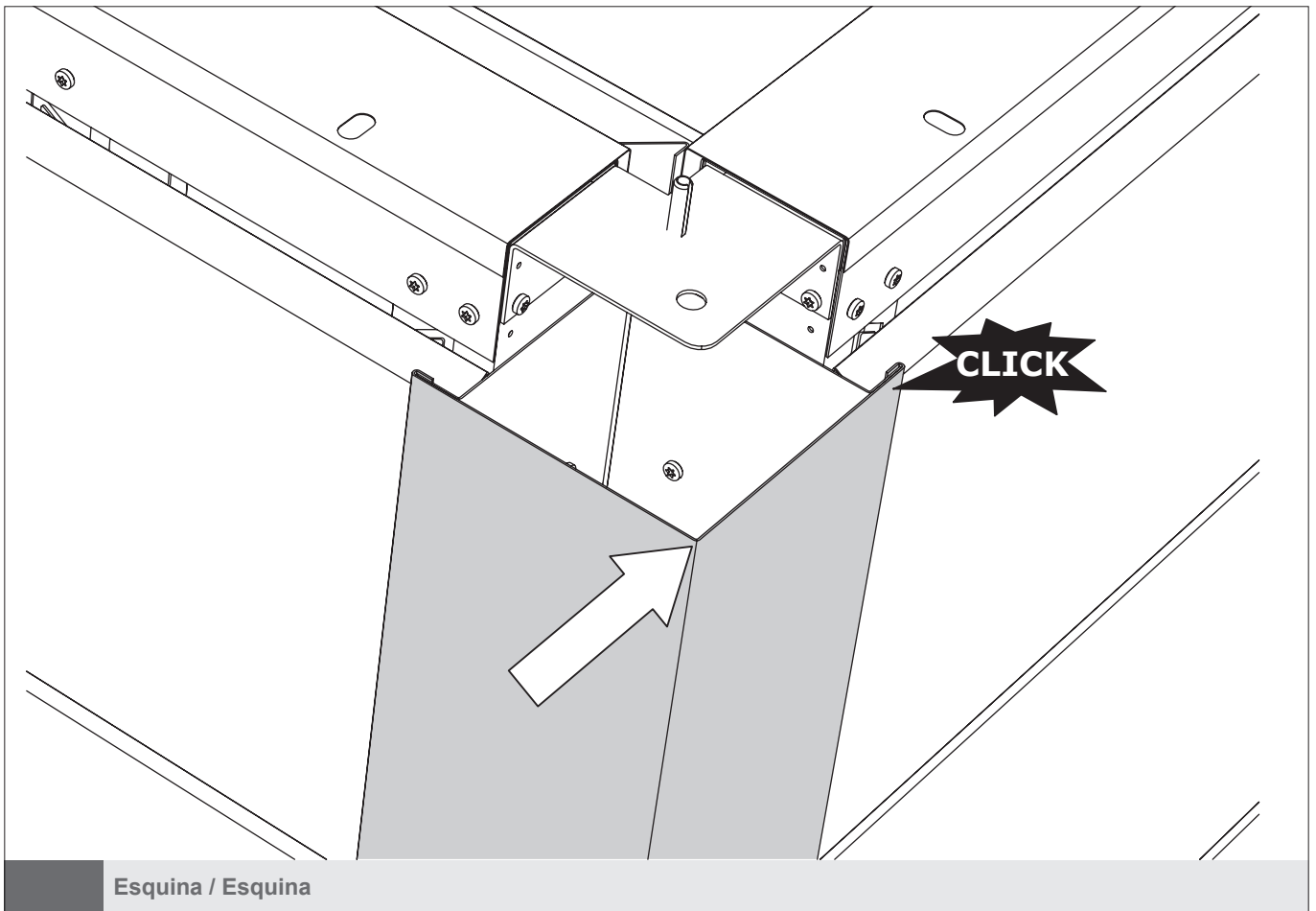

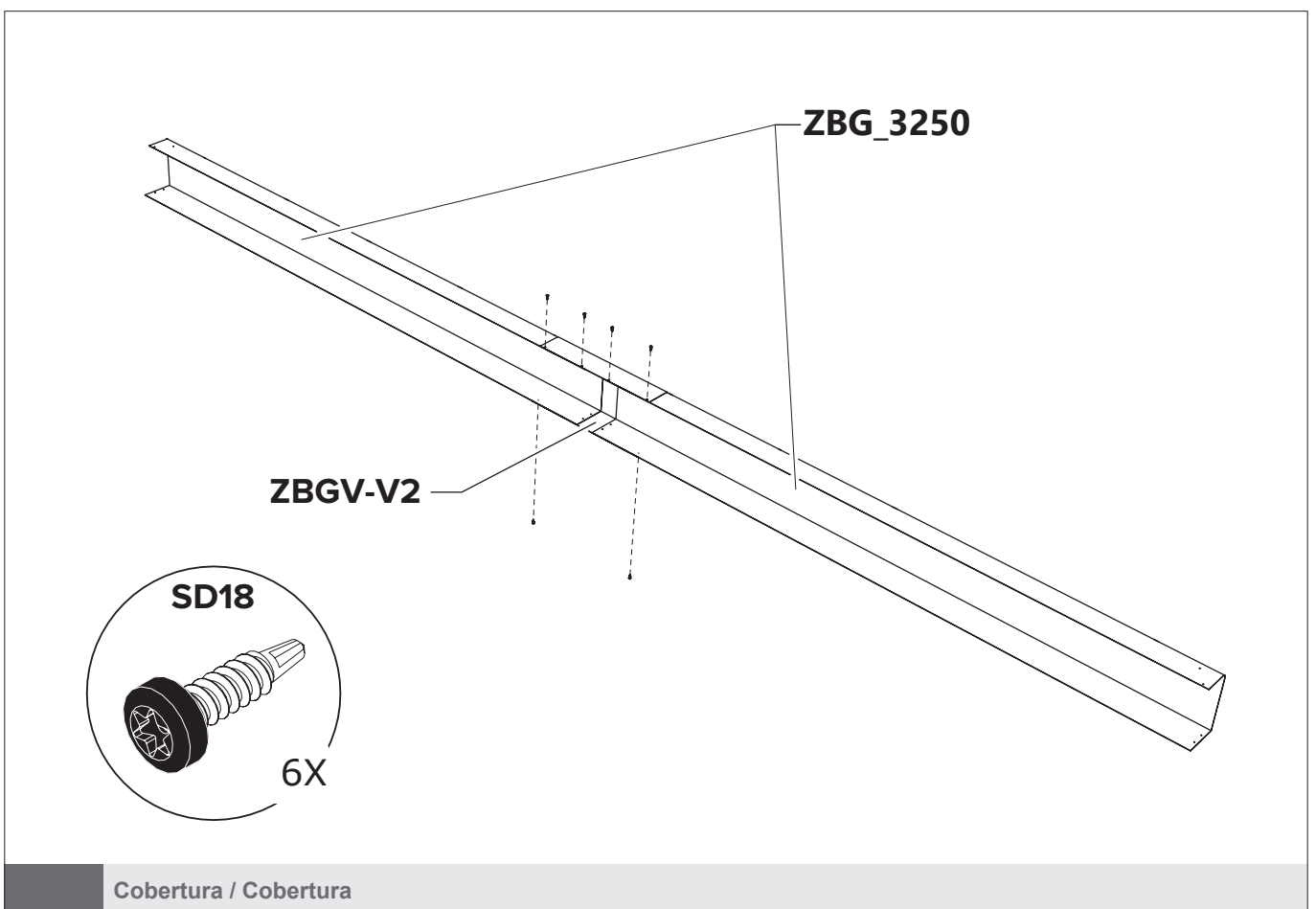
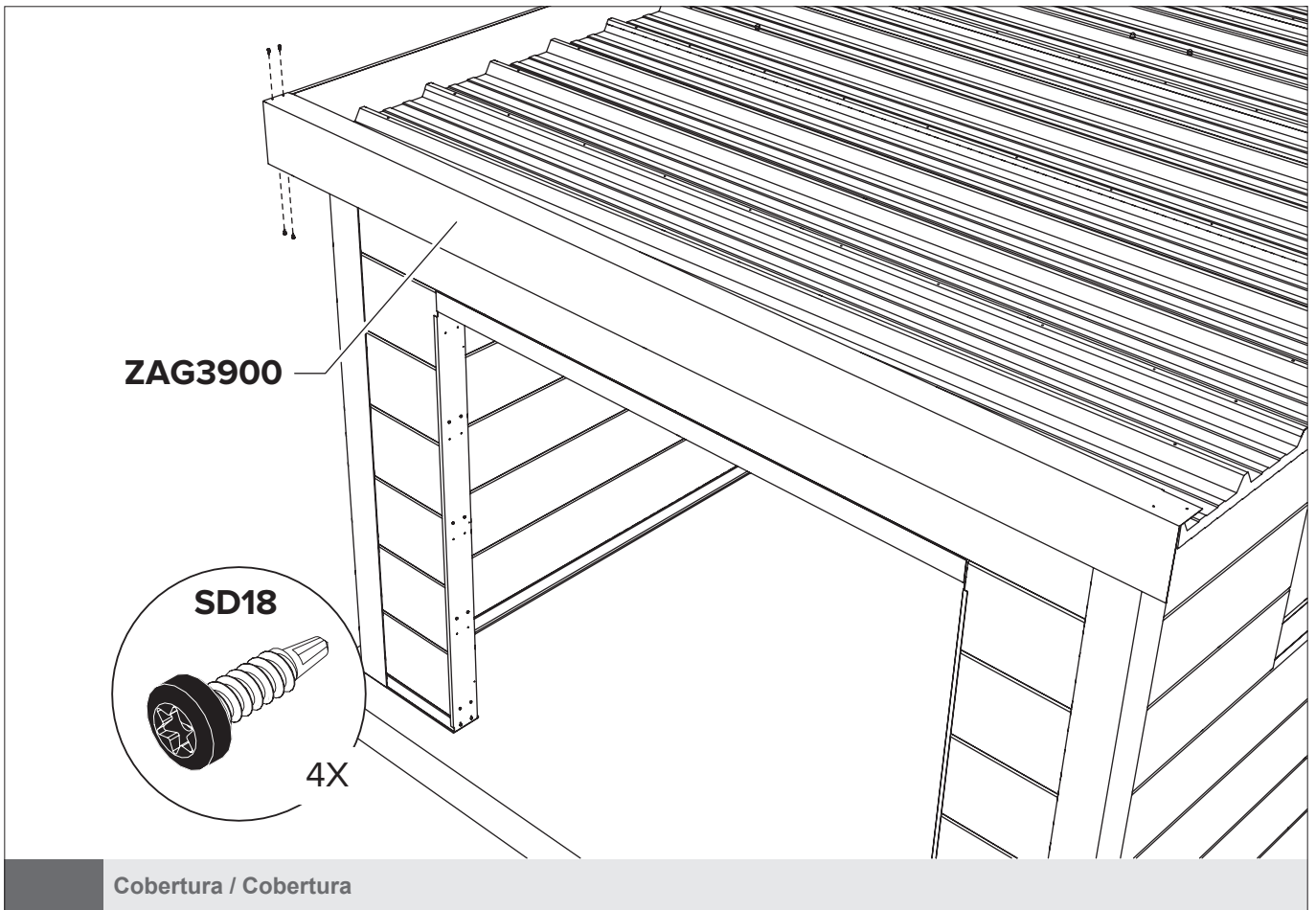

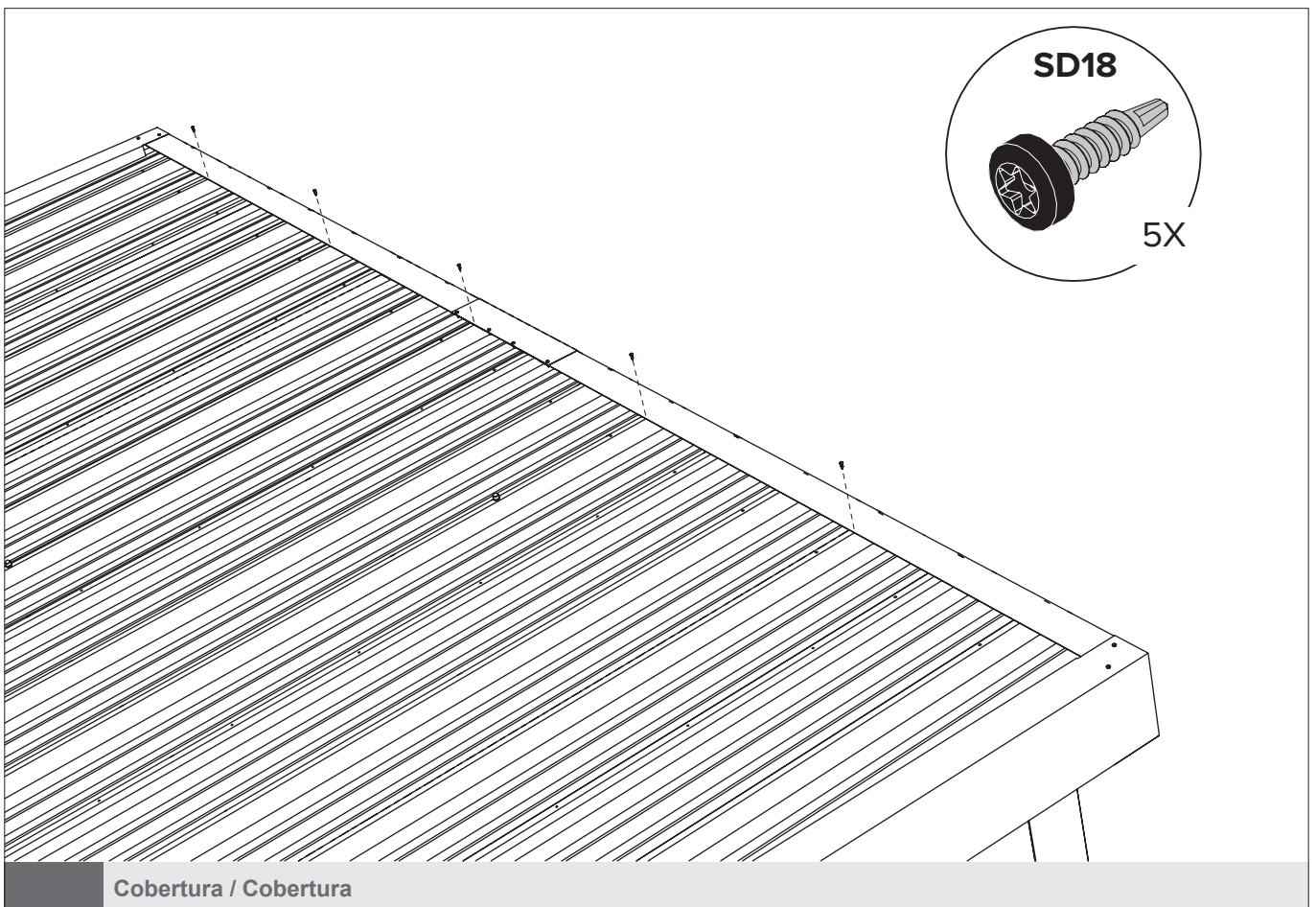

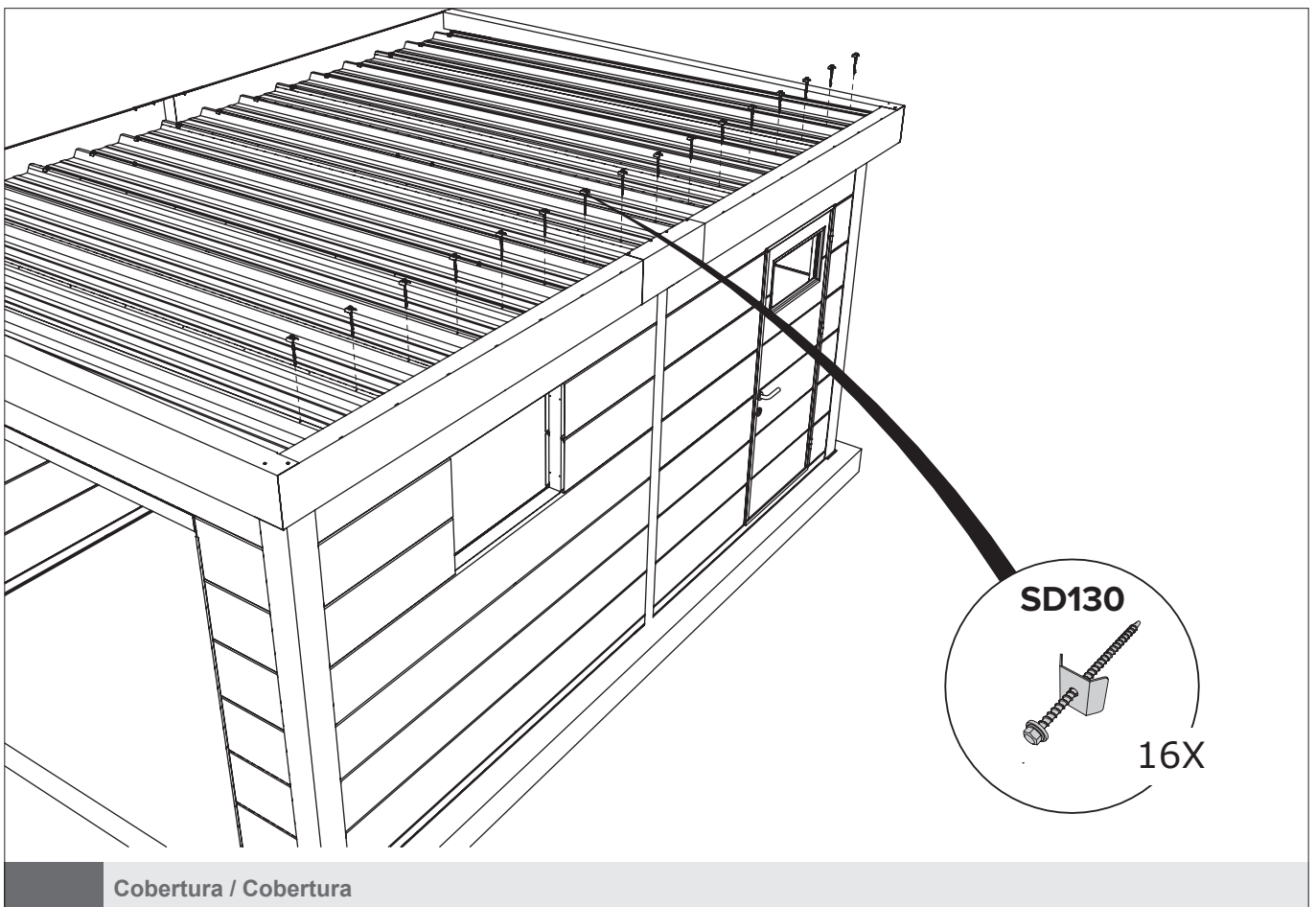
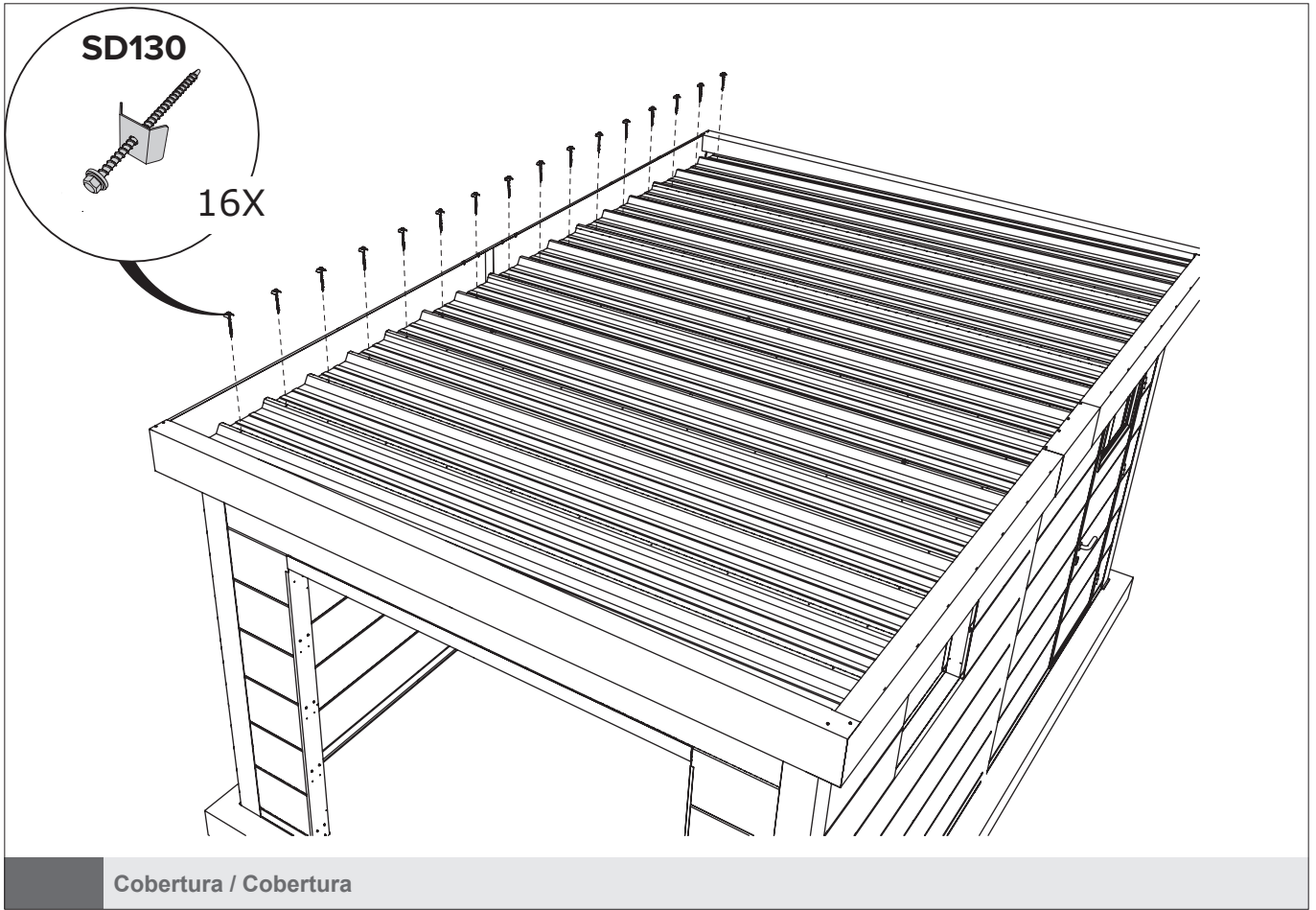

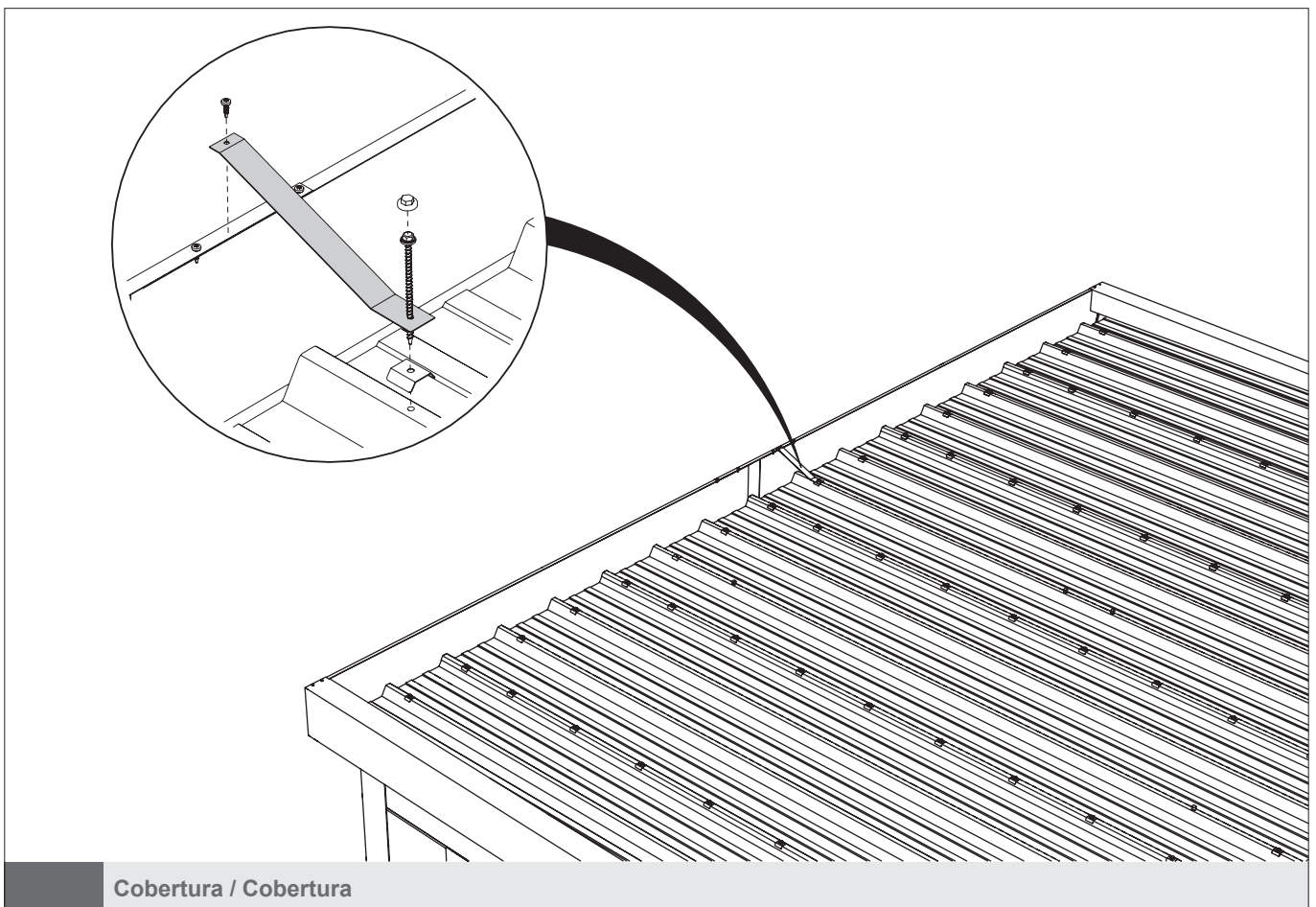
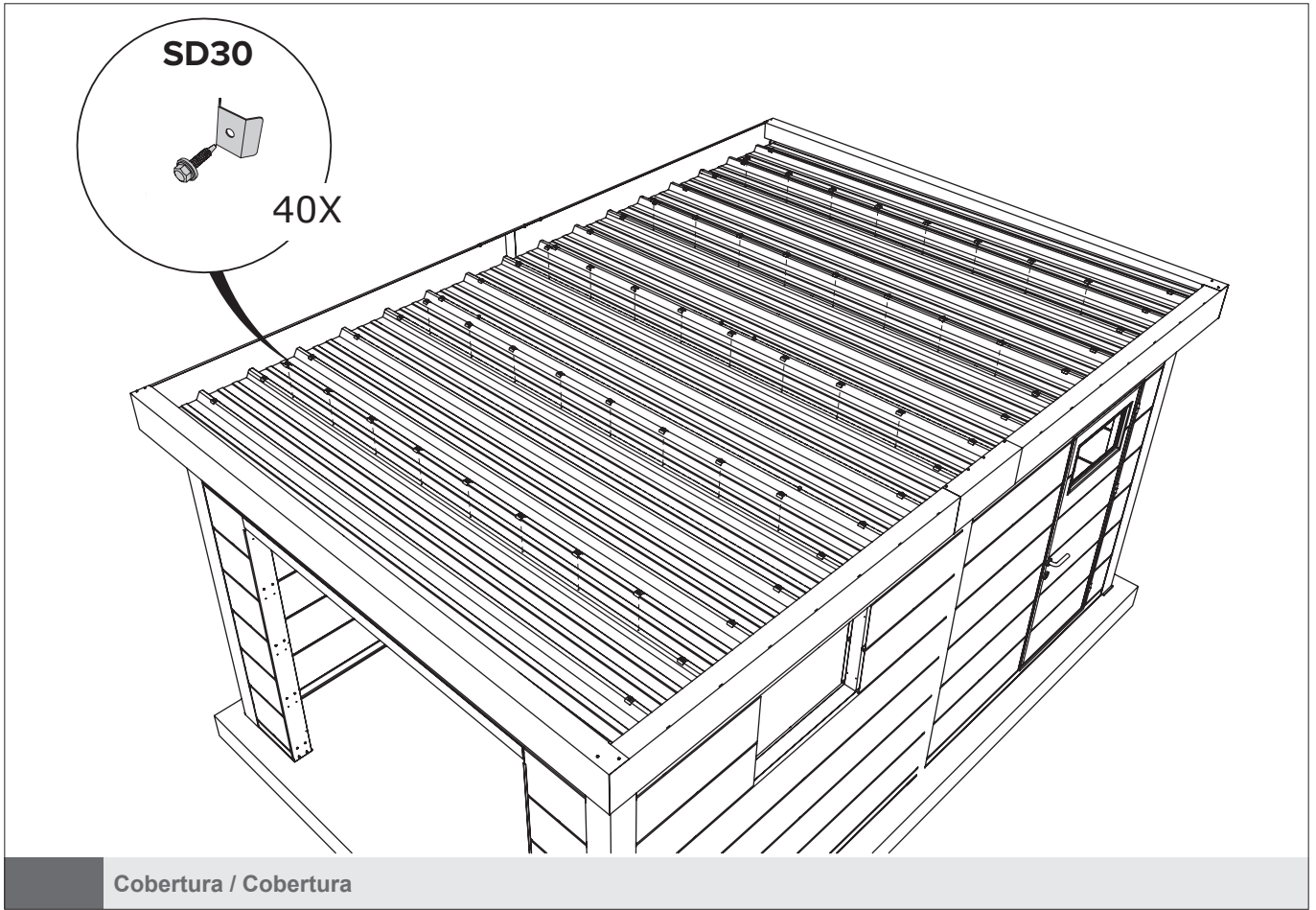

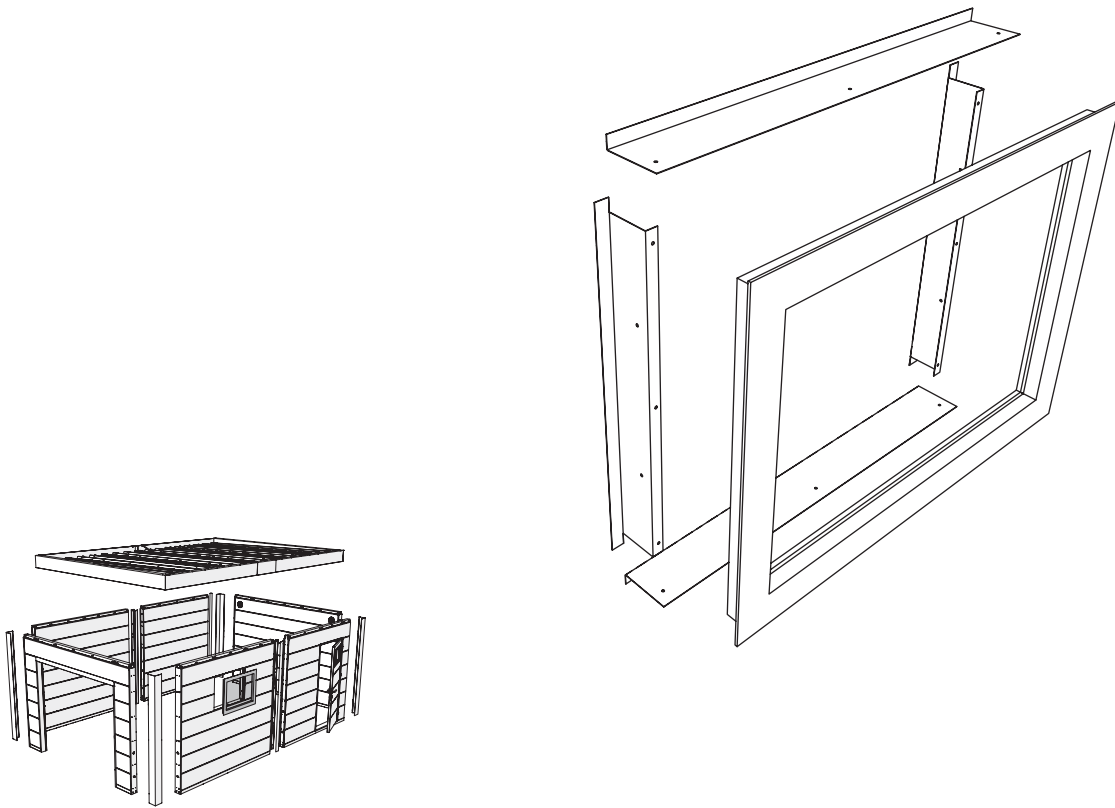

Janela / Ventana

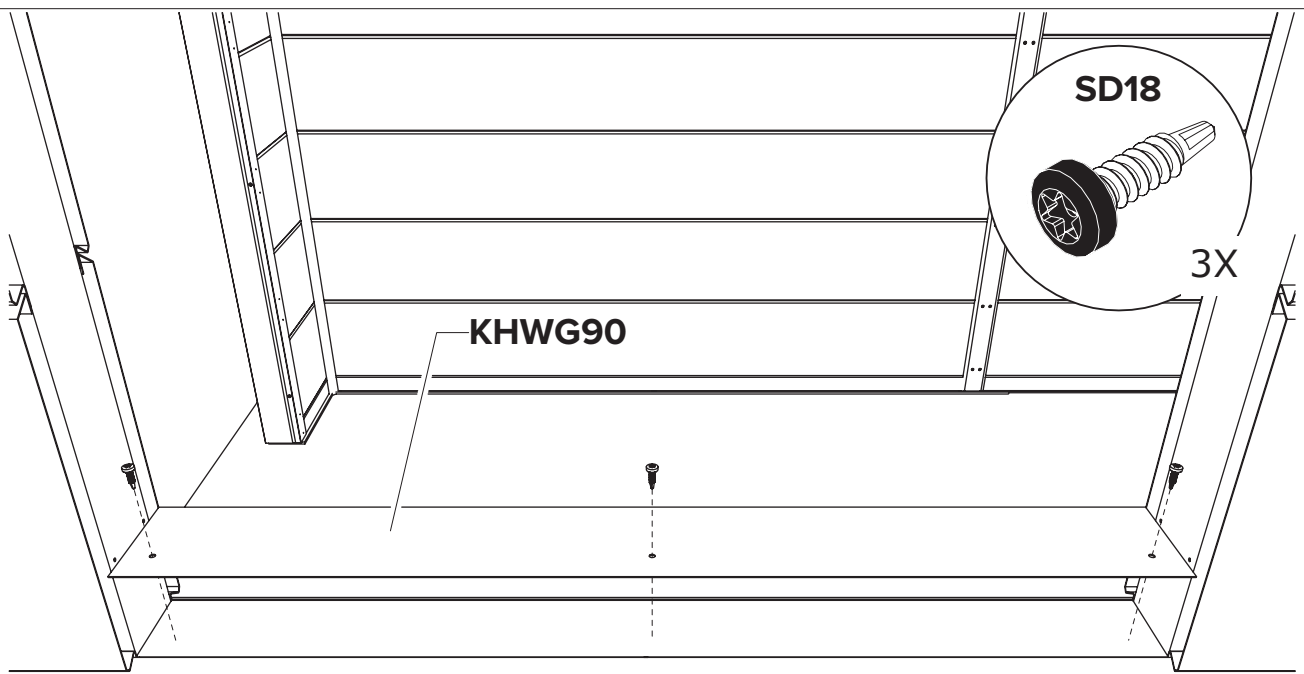

Janela / Ventana

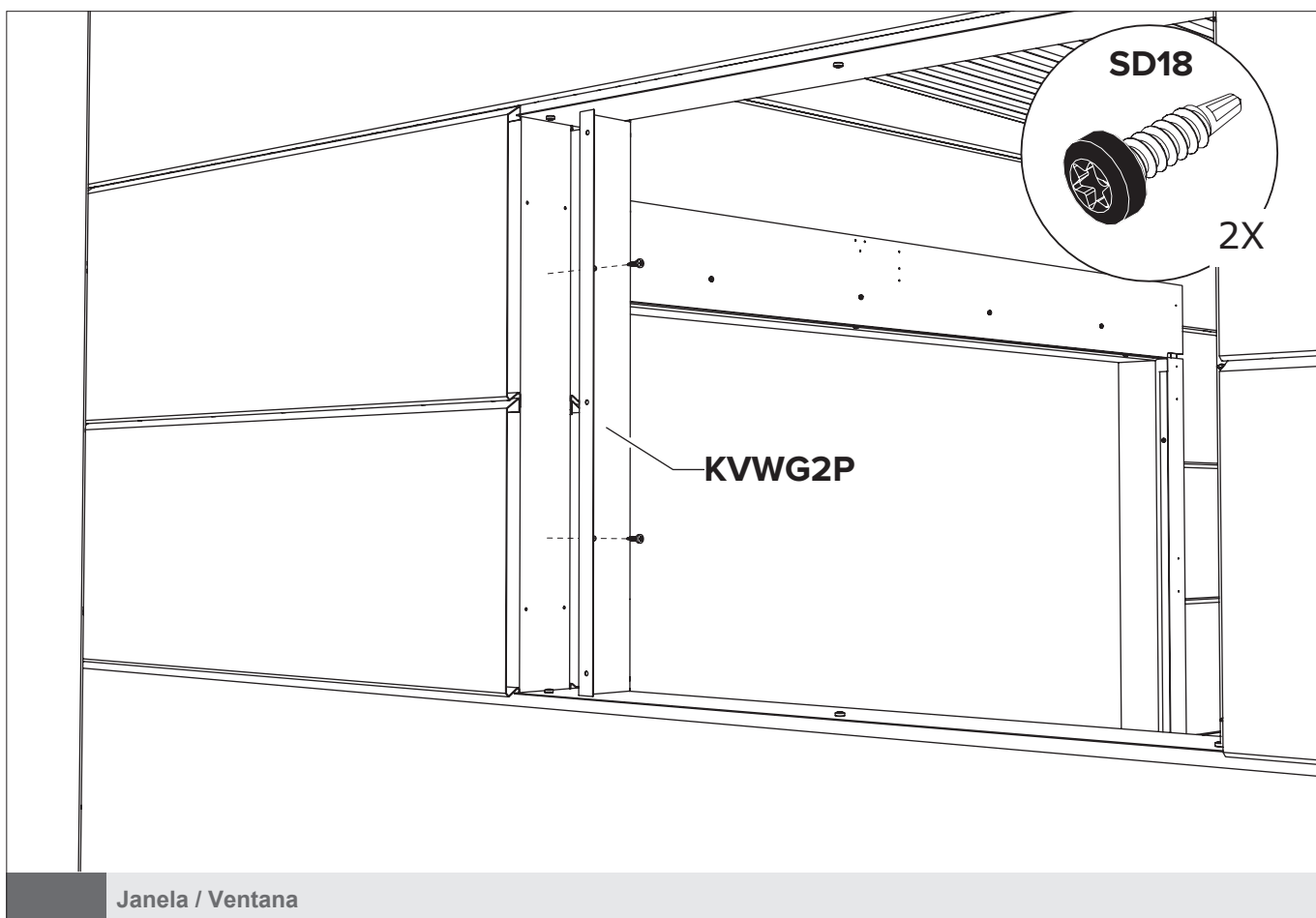
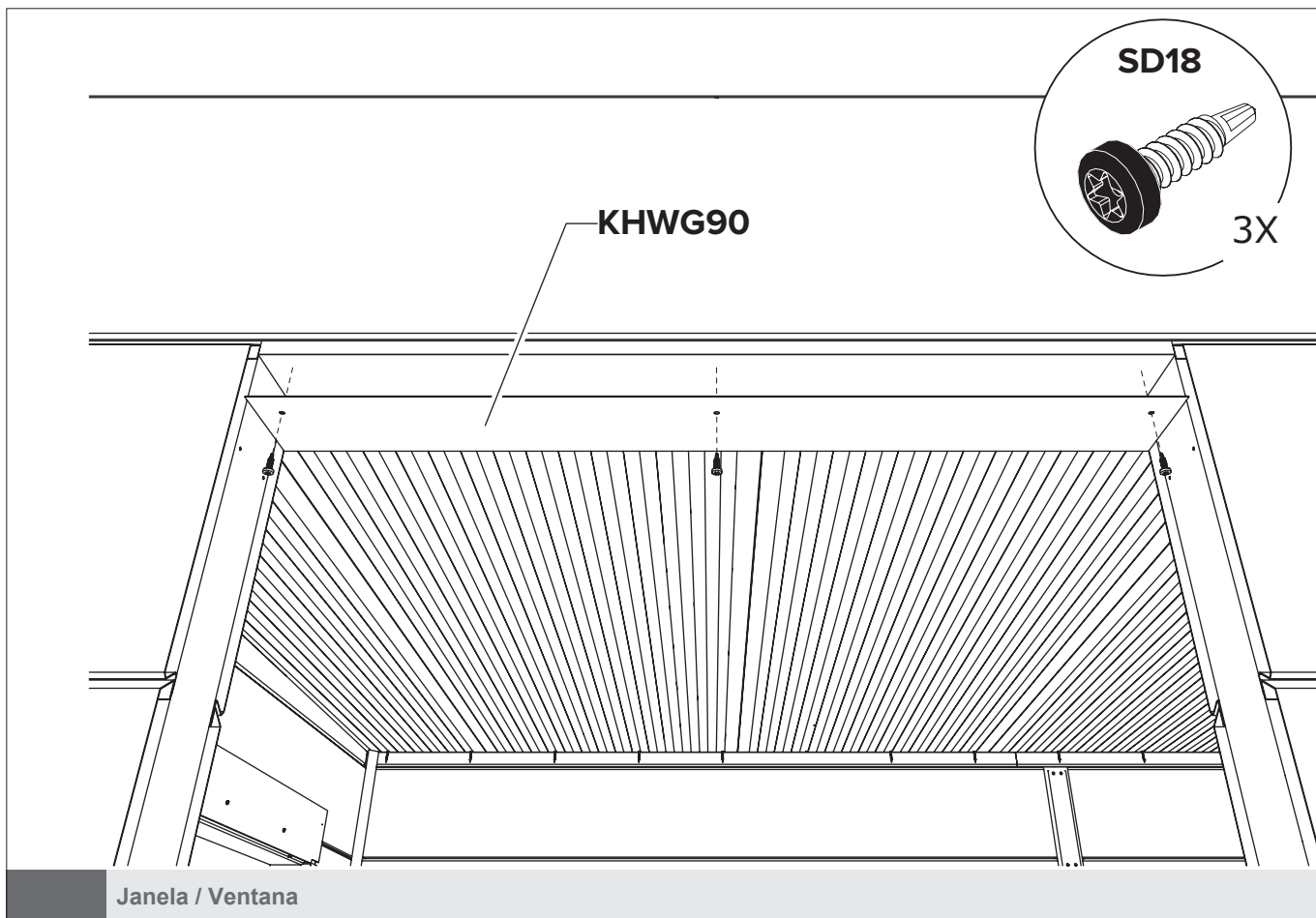

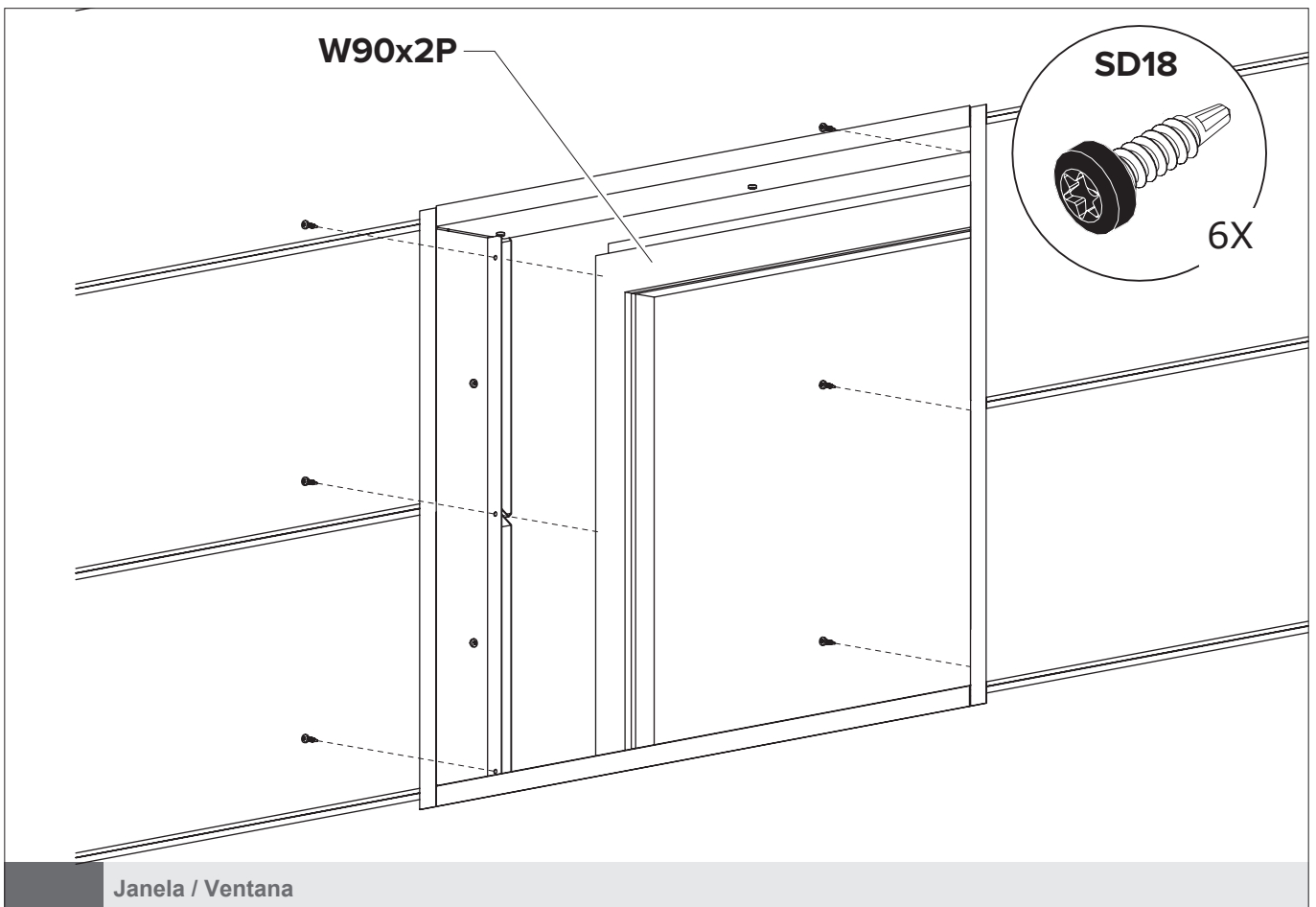
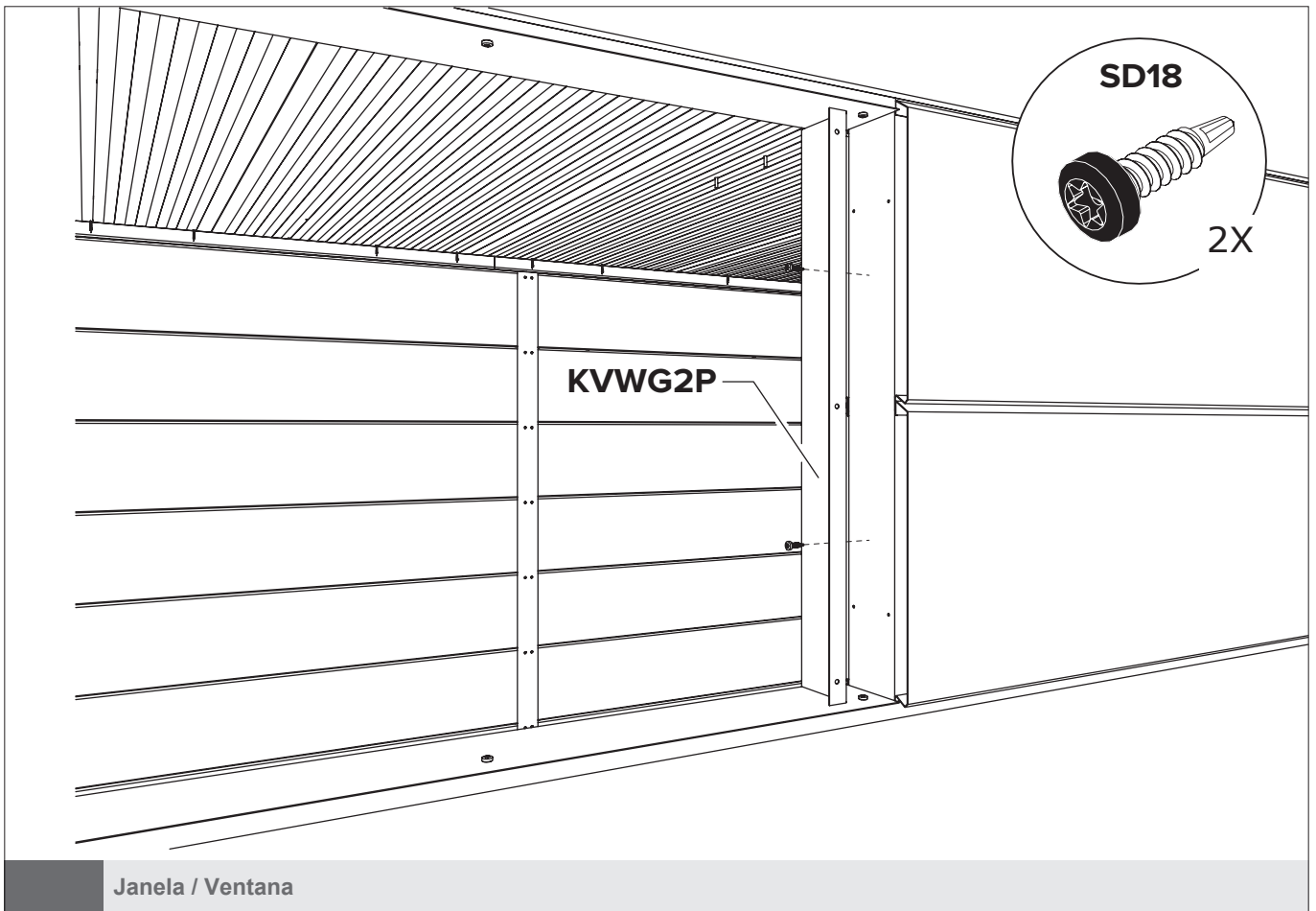

GARAGEM / GARAJE NH2

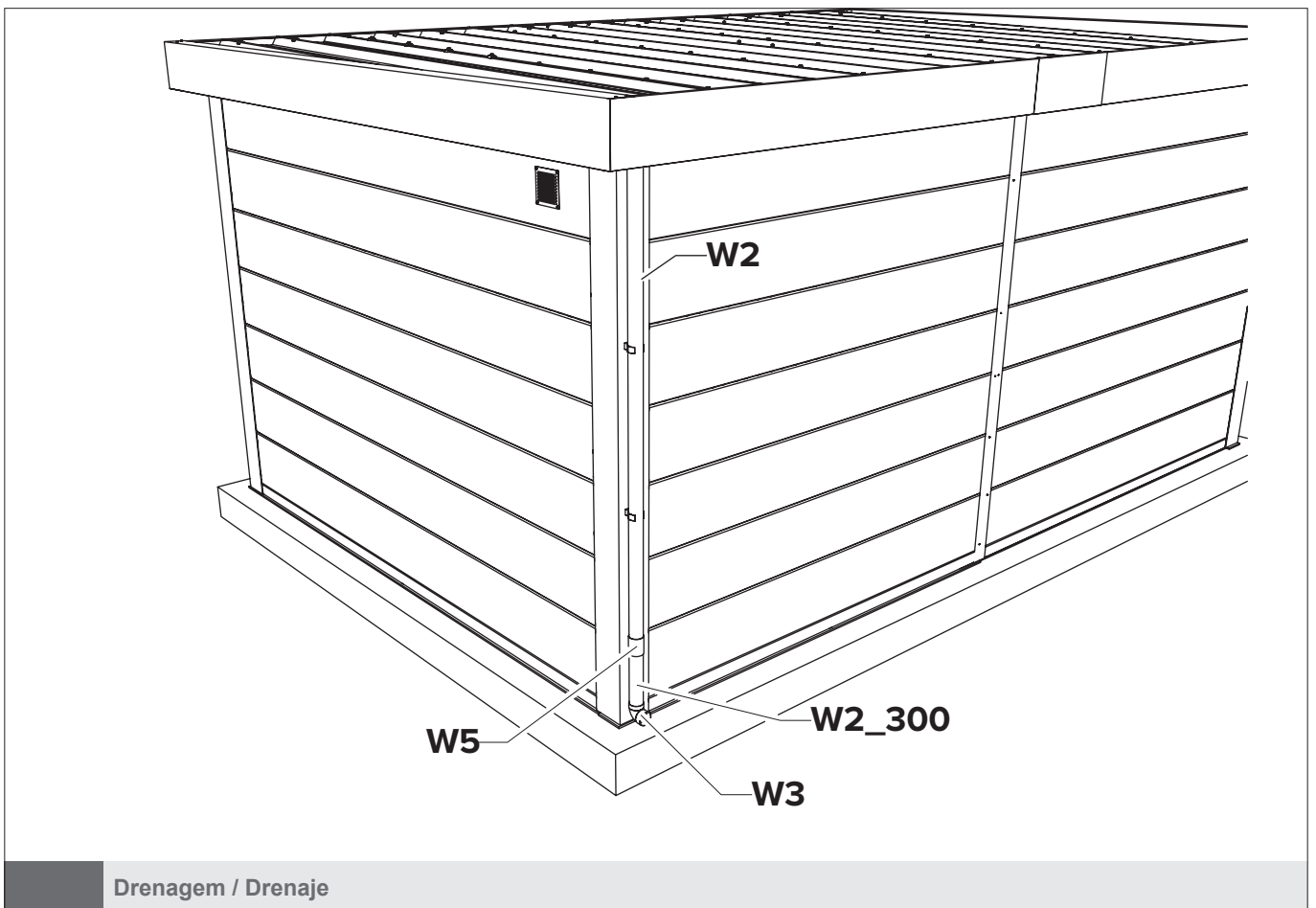
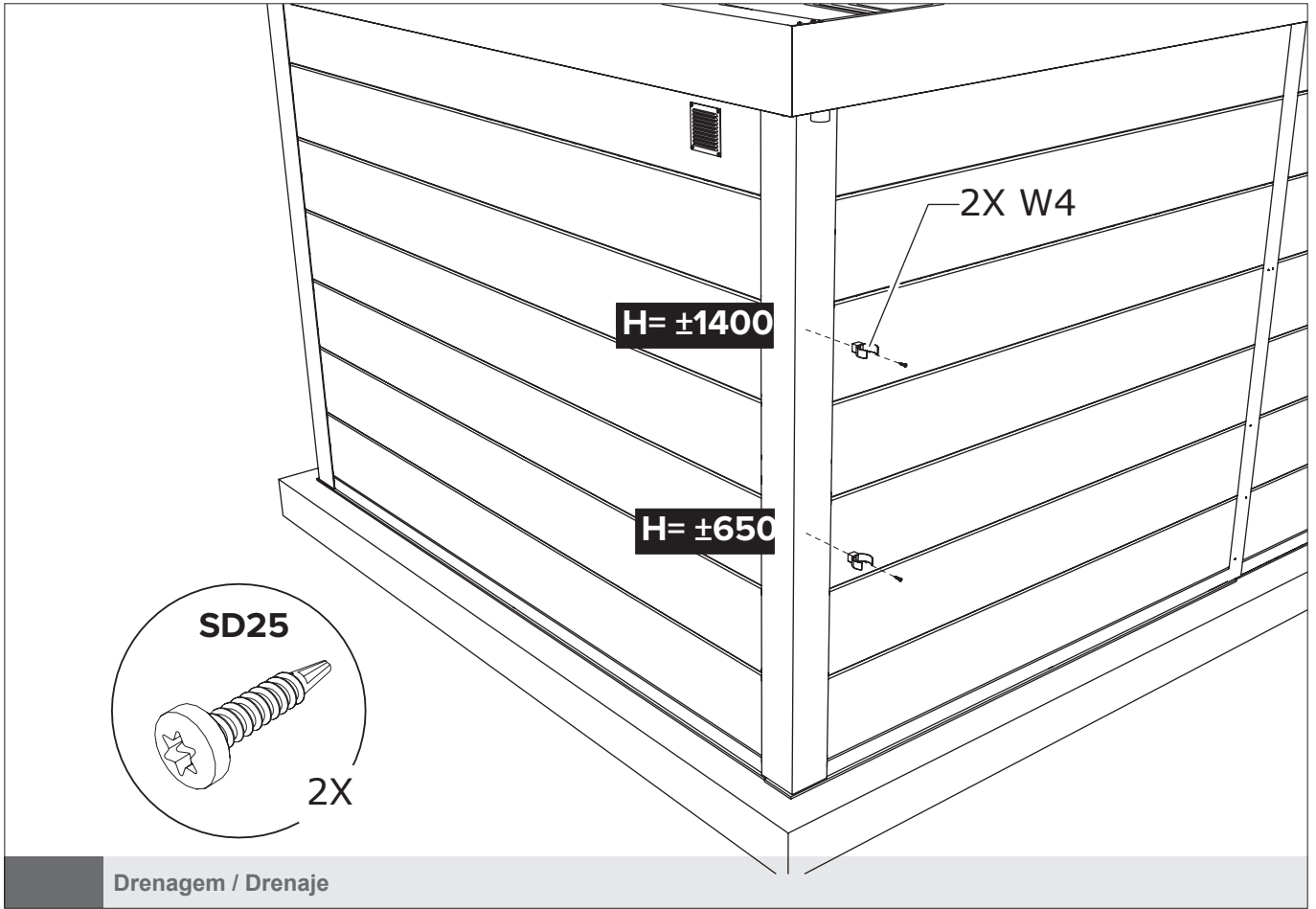

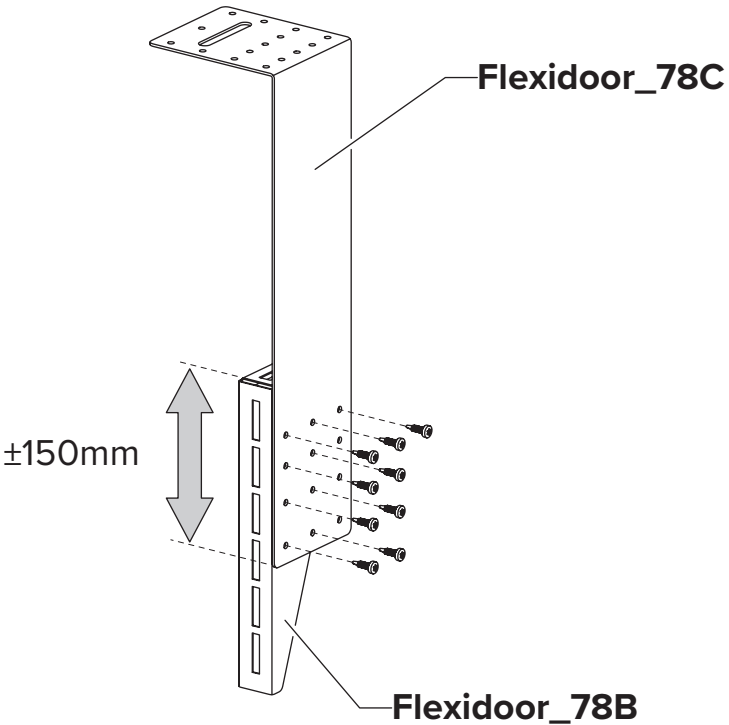
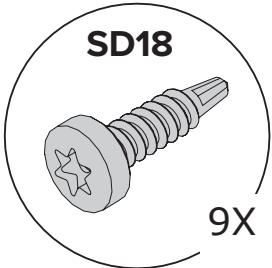

Porta seccionada / Puerta seccional

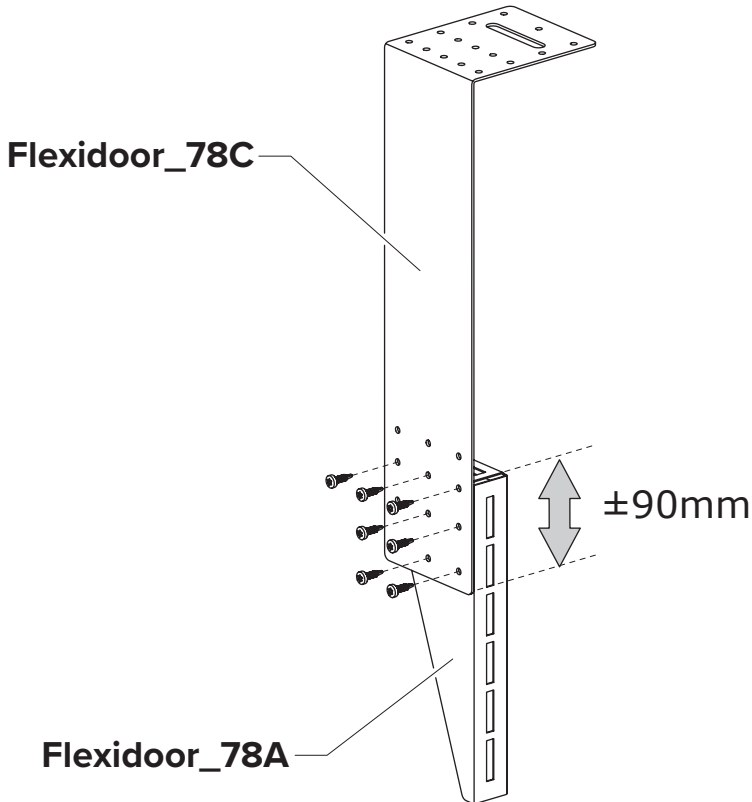

Porta seccionada / Puerta seccional

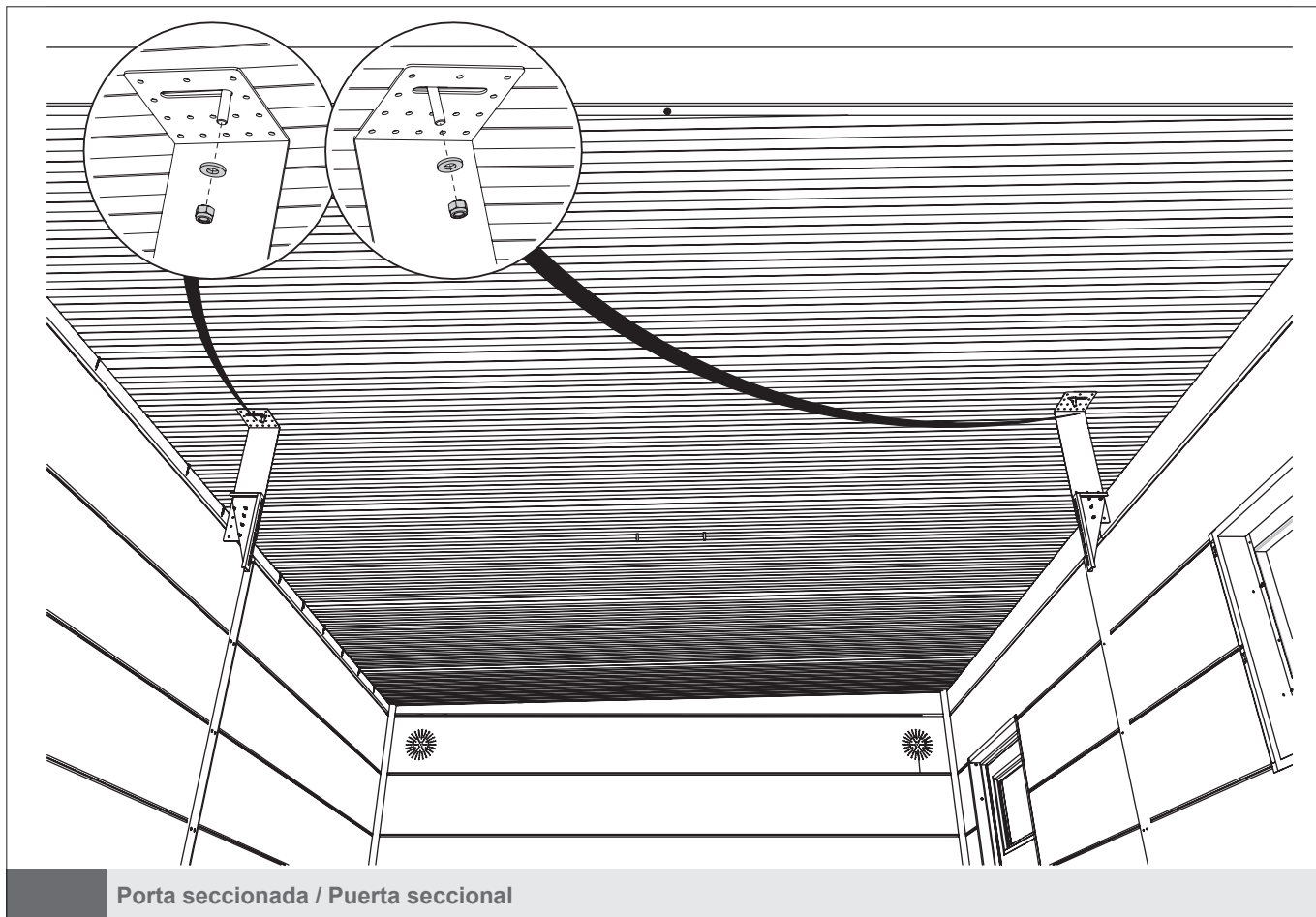

Porta seccionada / Puerta seccional

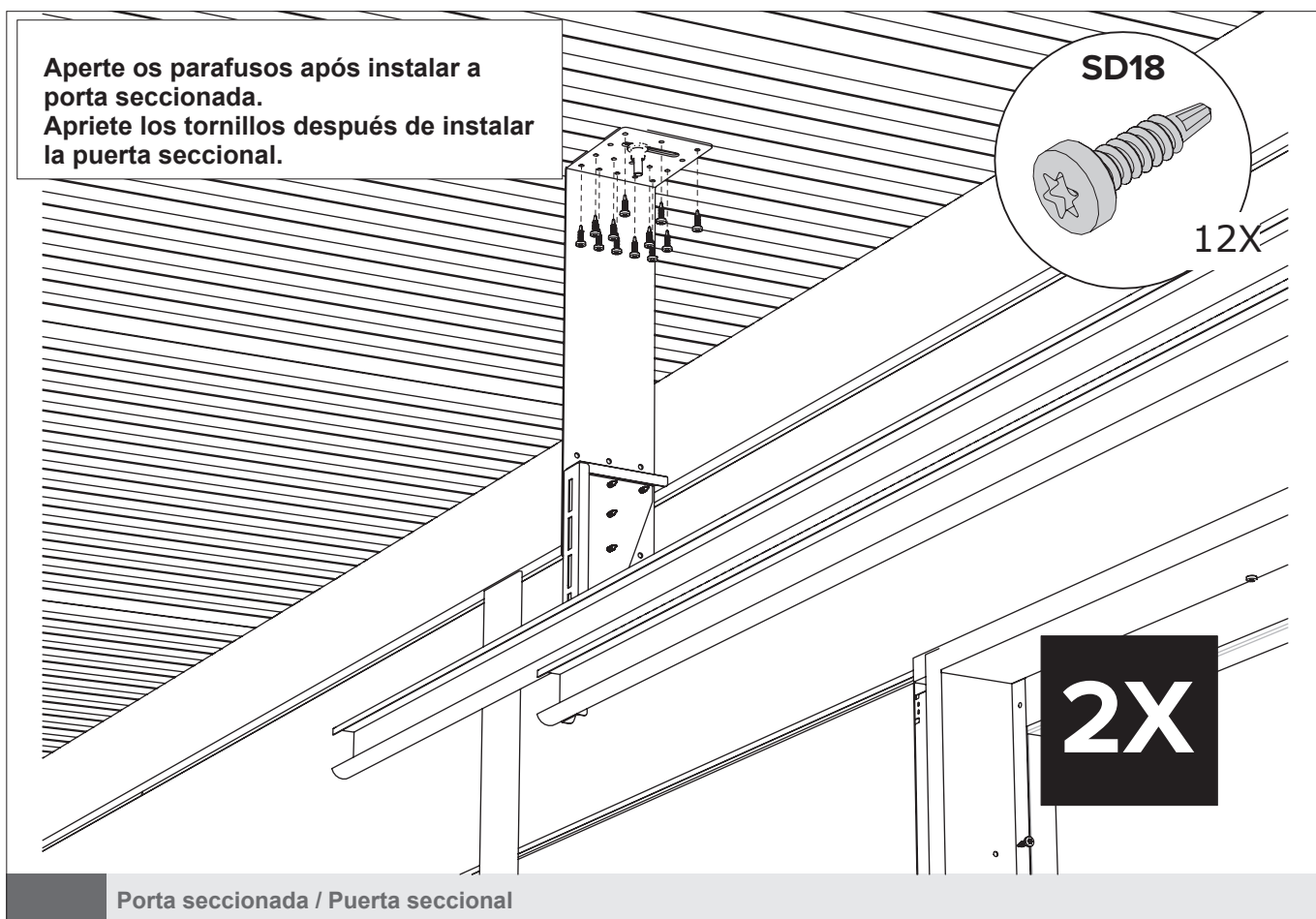

Porta seccionada / Puerta seccional

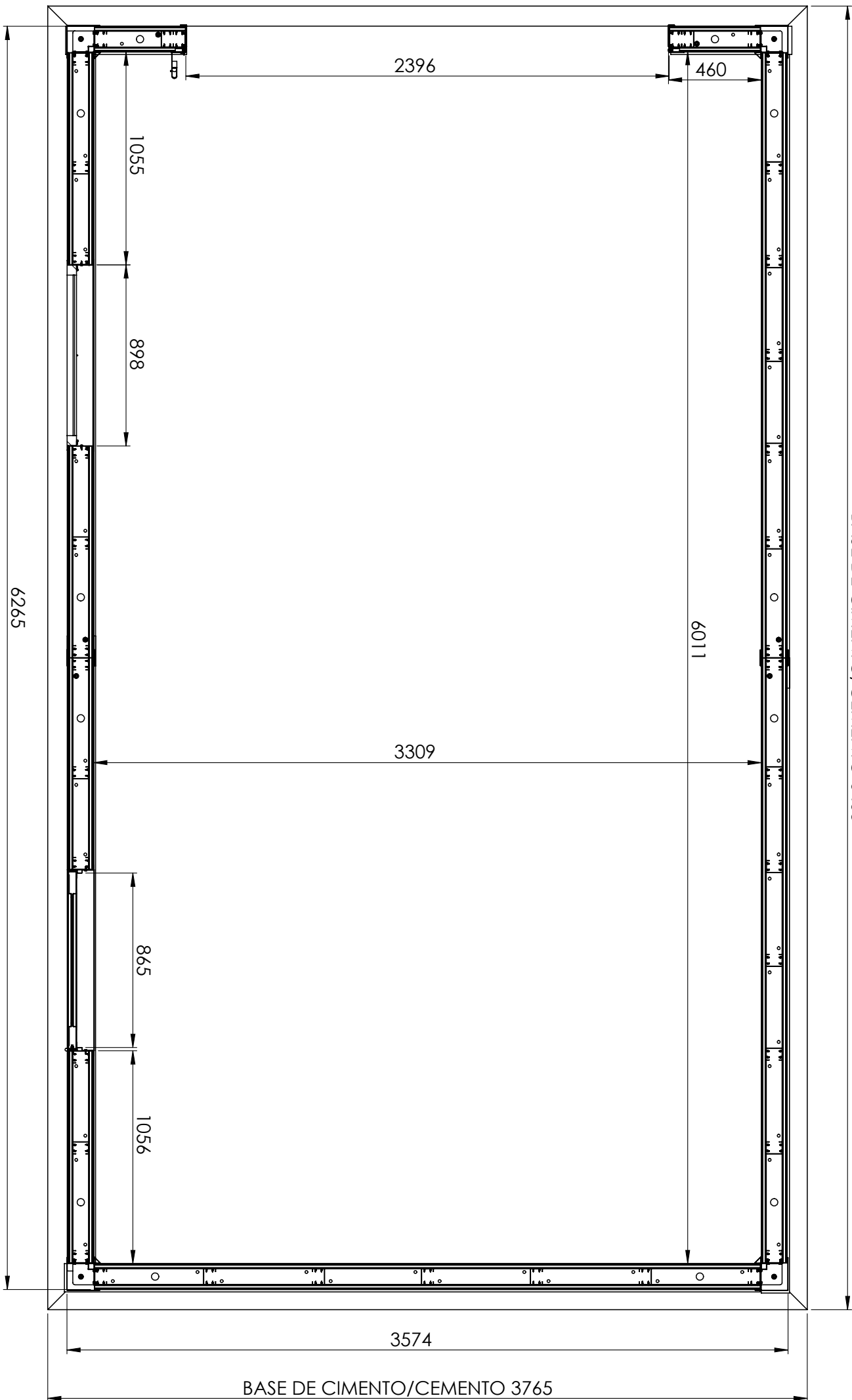

BASE DE CIMENTO/CEMENTO 6465

BASE DE CIMENTO/CEMENTO 3765